

NUMBER BUS-20-073	TYPE APPLICATION SPECIFICATION	Amphenol FCI	
TITLE Application Guide for Converged Metral™ Vertical Press Fit Signal Headers and Shrouds		PAGE 1 of 23	REVISION F
		AUTHORIZED BY S. ALOSIOUS	DATE 2018-01-08
CLASSIFICATION UNRESTRICTED			

1.0 OBJECTIVE

To provide information on available product features and customer application considerations for Converged Metral™ vertical press fit signal headers.

2.0 SCOPE

This application spec provides regarding product features, customer application machines (CAM's), and customer use.

3.0 GENERAL

3.1 This document is meant to be an application guide. If information varies from that in the product drawings and specifications, the drawings and specifications take precedence.

3.2 This document contains the following sections:

<u>Paragraph</u>	<u>Title</u>	<u>Page</u>
1.0	Objective	1
2.0	Scope	1
3.0	General	1
4.0	Procedure	2
4.1	Introduction	2
4.2	General Information	4
4.3	Part Information	6
4.4	Materials	10
4.5	PCB Requirements	11
4.6	Customer Design Considerations	13
4.7	CAM's (Customer Application Machines)	13
4.7.1	Header Insertion Tooling	13
4.7.2	Header Removal Tooling	14
4.7.3	Shroud Insertion Tooling	17
4.7.4	Shroud Removal Tooling	18
4.7.5	Presses	19
4.8	Order Forms	21
5.0	Reference Documents	23
6.0	Record Retention	23

3.3 Banned/Restricted Substances

All product where the part number ends in 'LF' meet the European Union directives and other country regulations as described in GS-22-008. The part numbers that do not end in 'LF' meet all regulations except for Pb in SnPb plating.

3.4 Manufacturing Processability

All products covered by this specification except those with part number containing '-N' will withstand exposure to 260°C for 60 seconds in a convection, infra-red or vapor phase reflow oven. Part numbers with '-N' will not withstand reflow and the Au contact surface of the contacts shall be exposed to a maximum of 140°C for no longer than 15 seconds in a wave solder operation.

NUMBER BUS-20-073	TYPE APPLICATION SPECIFICATION	Amphenol FCI	
TITLE Application Guide for Converged Metral™ Vertical Press Fit Signal Headers and Shrouds		PAGE 2 of 23	REVISION F
		AUTHORIZED BY S. ALOSIOUS	DATE 2018-01-08
CLASSIFICATION UNRESTRICTED			

4.0 PROCEDURE

4.1 Introduction

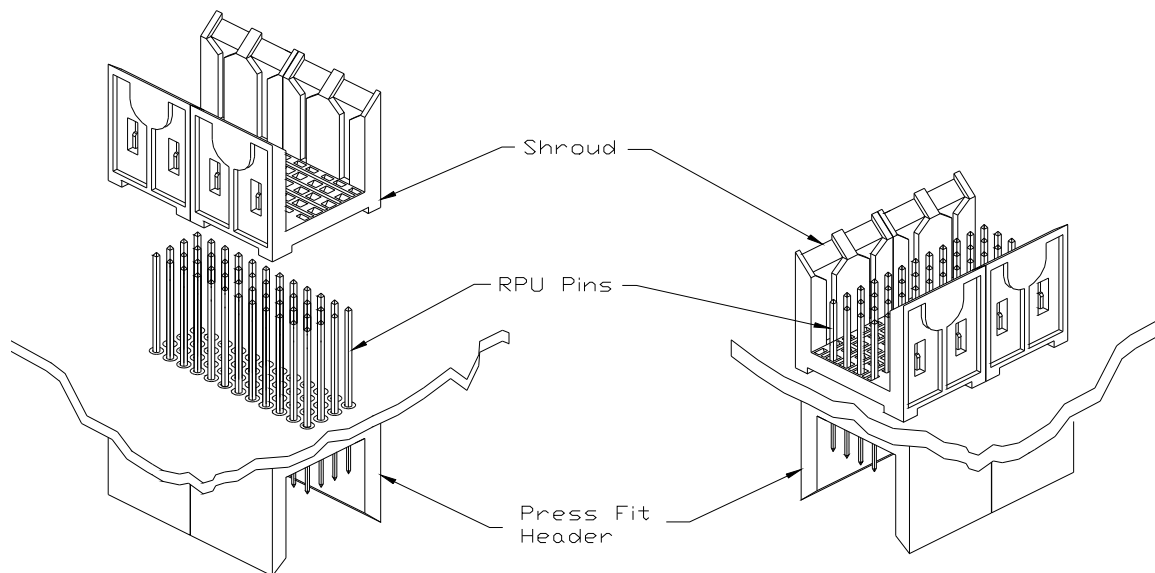

Figure 1 - Isometric view of a press fit header and a shroud.

A compliant press fit connection is achieved by mechanically inserting a pin into a Plated Thru Hole (PTH). The electrical connection is maintained by the normal forces generated by the compliant section to the PTH walls. There are a number of benefits in the use of press fit connections. First, by using a press fit connection, it eliminates the need for soldering processes. Second, it reduces re-work concerns on the connectors by allowing single pin repair. Third, press fit headers offer Rear Plug Up (RPU) capability. This enables plugging to both sides of the Printed Circuit Board (PCB) without using any additional space on the board. Shrouds are used when RPU or midplane applications are required. The shrouds are pressed over the RPU tails of the press fit header. These shrouds come with various stand off heights, which, coupled with the multiple tail lengths available on the vertical press fit header, gives many possibilities for the mating length of the pins on the rear side.

The “Eye of the Needle” compliant section was designed to meet the requirements for press fit terminations according to Bellcore GR-1217-Core. This applies to SnPb plated boards and also OSP boards (An OSP board uses copper plating only, which is passivated to prevent corrosion of the copper). The performance requirements specified in this document are:

- There shall not be an increase in contact resistance greater than 1m-Ω after environmental stress.
- Average hole deformation shall not exceed 0.0015”
- Maximum hole deformation shall not exceed 0.002”

NUMBER BUS-20-073	TYPE APPLICATION SPECIFICATION	Amphenol FCI	
TITLE Application Guide for Converged Metral™ Vertical Press Fit Signal Headers and Shrouds		PAGE 3 of 23	REVISION F
		AUTHORIZED BY S. ALOSIOUS	DATE 2018-01-08
		CLASSIFICATION UNRESTRICTED	

Figure 2 shows a cross section of the “Eye of the Needle” that is used in Converged Metral™ press fit headers. Figure 3 illustrates a typical cross-section of a press fit pin inserted in a PCB.

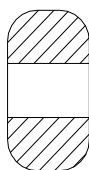

Figure 2 – Eye of the Needle shape on the vertical press fit pin.



Figure 3 - Cross-section of vertical press fit pin in the middle of a PCB.

NUMBER BUS-20-073	TYPE APPLICATION SPECIFICATION	Amphenol FCI	
TITLE Application Guide for Converged Metral™ Vertical Press Fit Signal Headers and Shrouds		PAGE 4 of 23	REVISION F
		AUTHORIZED BY S. ALOSIOUS	DATE 2018-01-08
CLASSIFICATION UNRESTRICTED			

4.2 General Information

The vertical press fit Converged Metral™ header is available in 4 and 5 row configurations. The features of this connector are:

- Modular building block based on a 12 mm standard modular size (e.g. 4 x 6 & 5 x 6 modules are 12 mm long, 4 x 12 & 5 x 12 modules are 24 mm long, 4 x 24 & 5 x 24 modules are 48 mm long, etc.).
- The contacts are located on a 2 mm x 2 mm grid for high signal density.
- Sizes available from 1 module to 13 modules (12 mm to 156 mm).
- Stackable with other Metral™ products (e.g., power, coax, guide pin).
- First Make/Last Break capability to support Hot Plugging applications. See Tables 12 & 13.
- Customer specific select load. See Tables 12 & 13.
- Rear Plug Up (RPU) supporting midplane or cable applications.
- Current Rating
 - 3 A for a single contact.
 - 1 A when all contacts are powered.
- Dielectric Withstanding Voltage of 1000 V rms (at sea level).
- Insulation Resistance of 5000 MW minimum initially; 1000 MW after environmental testing.

Table 1 - Length and part numbers for available vertical press-fit headers.

Number of Modules	Length (mm)	4 Row PN Std Load	4 Row PN Select Load	5 Row PN Std Load	5 Row PN Select Load
1	12	70232-XYX	88921-XYZ	89006-XYX	89025-XYX
2	24	70233-XYX	88922-XYZ	89007-XYX	85853-XYX
3	36	70451-XYZ	70451-XYZ	73932-XYXX	73932-XYXX
4	48	70234-XYX	88923-XYZ	89008-XYX	85854-XYX
5	60	70452-XYZ	70452-XYZ	73933-XYXX	73933-XYXX
6	72	70453-XYZ	70453-XYZ	73934-XYXX	73934-XYXX
7	84	70454-XYZ	70454-XYZ	73935-XYXX	73935-XYXX
8	96	70235-XYX	88924-XYZ	89009-XYX	85855-XYX
9	108	70455-XYZ	70455-XYZ	73936-XYXX	73936-XYXX
10	120	70456-XYZ	70456-XYZ	73937-XYXX	73937-XYXX
11	132	70457-XYZ	70457-XYZ	73938-XYXX	73938-XYXX
12	144	70458-XYZ	70458-XYZ	73939-XYXX	73939-XYXX
13	156	70459-XYZ	70459-XYZ	73940-XYXX	73940-XYXX

- The -XYX in the part numbers stand for the following:
 - X – Contact Area Finish (Plating)
 - Y – Sequential designation of different pin loading configurations.

NUMBER BUS-20-073	TYPE APPLICATION SPECIFICATION	Amphenol FCI	
TITLE Application Guide for Converged Metral™ Vertical Press Fit Signal Headers and Shrouds		PAGE 5 of 23	REVISION F
		AUTHORIZED BY S. ALOSIOUS	DATE 2018-01-08
CLASSIFICATION UNRESTRICTED			

Table 2 - The plating specification and the suffix for ordering.

PLATING IN CONTACT AREA	
DASH NUMBER	PERFORMANCE LEVEL
-N1YY	TELCORDIA CO (NXT)
-N5YY	TELCORDIA UE (NXT)
-1YY	TELCORDIA CO
-2YY	TETECOM CLASS
-3YY	IEC CLASS 1
-5YY	TELCORDIA UE
-9YY	TELCORDIA CO

Table 3 - Length and part numbers for available shrouds.

Number of Modules	Length (mm)	4 Row PN	5 Row PN
1	12	70203-1YZ	89055-1YZ
2	24	70203-1YZ	89055-1YZ
4	48	70203-1YZ	89055-1YZ
8	96	70203-1YZ	89055-1YZ

- The -1YZ in the part number stands for the following:
 - Y – Standoff height of shroud
 - Z – Number of modules in shroud

Table 4 - Order data for shroud standoff height.

Suffix	Standoff Height (mm)	Application
-11Z	3.50	Rear Plug Up
-12Z	4.40	Rear Plug Up
-13Z	6.90	Wire Wrap & Rear Plug Up

NUMBER BUS-20-073	TYPE APPLICATION SPECIFICATION	Amphenol FCI	
TITLE Application Guide for Converged Metral™ Vertical Press Fit Signal Headers and Shrouds		PAGE 6 of 23	REVISION F
		AUTHORIZED BY S. ALOSIOUS	DATE 2018-01-08
CLASSIFICATION UNRESTRICTED			

Table 5 - Ordering data for shroud length.

Suffix	Number of Modules	Length (mm)
-1Y1	1	12
-1Y2	2	24
-1Y3	4	48
-1Y4	8	96

4.3 Part Information

- Five different mating lengths are available on the press fit header, as shown in Figure 4, enabling First Make/Last Break (Hot Plugging).
- True position of the pins is also shown in Figure 4.
- Three different stand off heights are available on the shrouds as shown in Figure 5.

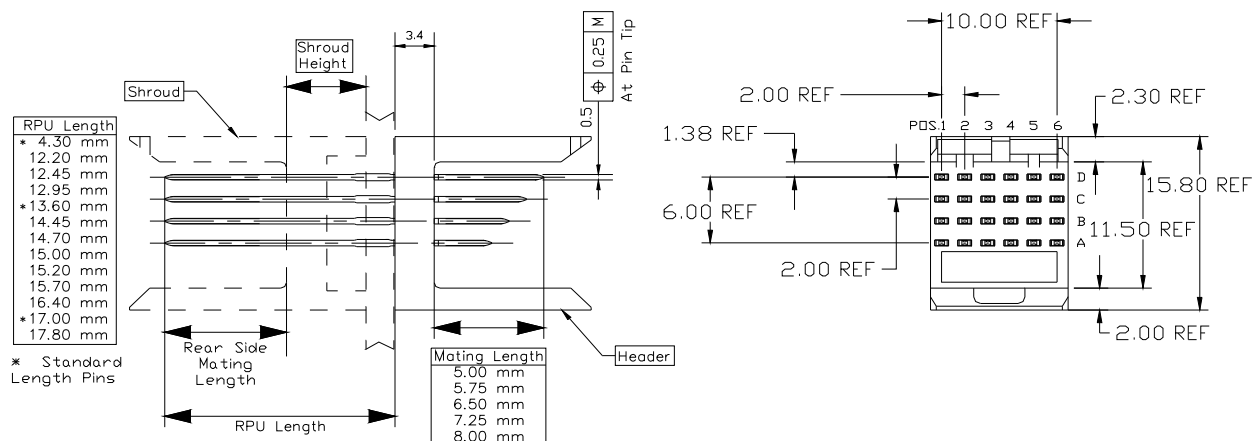

Figure 4 - Vertical press fit 4-row signal header. (All dimensions in mm)

NUMBER BUS-20-073	TYPE APPLICATION SPECIFICATION	Amphenol FCI	
TITLE Application Guide for Converged Metral™ Vertical Press Fit Signal Headers and Shrouds		PAGE 7 of 23	REVISION F
		AUTHORIZED BY S. ALOSIOUS	DATE 2018-01-08
CLASSIFICATION UNRESTRICTED			

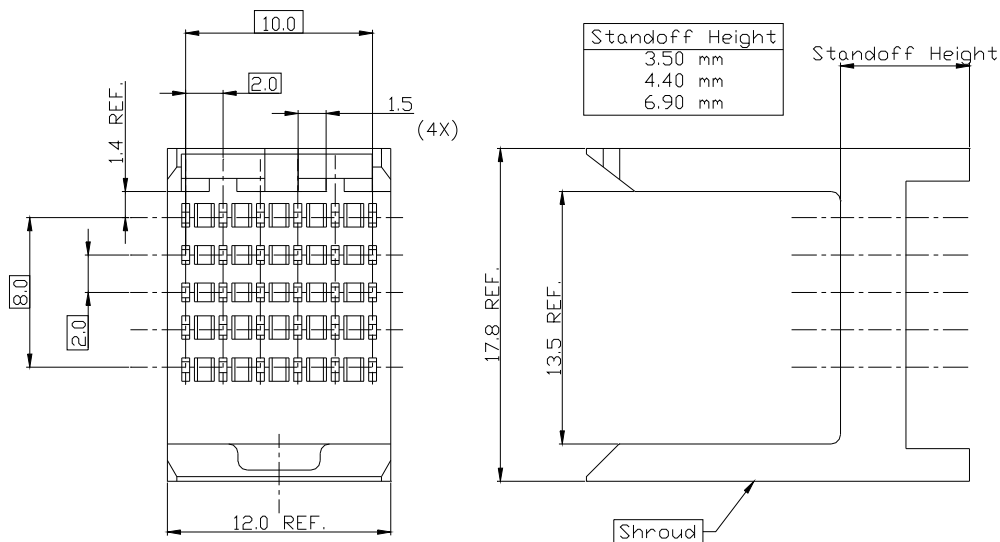

Figure 5 - Vertical 5-row shroud. (All dimensions in mm)

- Various tail lengths are available as shown in Figure 4. Rear Plug-up (RPU) options are also available to facilitate midplane applications and backside cabling. The use of the RPU pins necessitates the use of shrouds. The shrouds, coupled with the board thickness, determine the effective mating length of the RPU pins. Refer to Tables 6, 7, and 8 to find the effective mating length of the RPU pins.

Table 6 - Rear side pin lengths with a 3.5 mm shroud with various board thickness'.

PCB Thickness (mm)	1.6	2.4	3.2	4.0	4.8	5.6	6.4
Header Tail Length (mm)	EFFECTIVE REAR SIDE MATING LENGTH WITH 3.5 mm SHROUD						
* 4.30							
12.20	7.10	6.30	5.50				
12.45	7.35	6.55	5.75				
12.95	7.85	7.05	6.25	5.45			
* 13.60		7.70	6.90	6.10	5.30		
14.45			7.75	6.95	6.15	5.35	
14.70			8.00	7.20	6.40	5.60	
15.00				7.50	6.70	5.90	5.10
15.20				7.70	6.90	6.10	5.30
15.70					7.40	6.60	5.80
16.40						7.30	6.50
* 17.00						7.90	7.10
17.80							7.90

NUMBER BUS-20-073	TYPE APPLICATION SPECIFICATION	Amphenol FCI	
TITLE Application Guide for Converged Metral™ Vertical Press Fit Signal Headers and Shrouds		PAGE 8 of 23	REVISION F
		AUTHORIZED BY S. ALOSIOUS	DATE 2018-01-08
CLASSIFICATION UNRESTRICTED			

Table 7 - Rear side pin lengths with a 4.4 mm shroud with various board thickness¹.

PCB Thickness (mm)	1.6	2.4	3.2	4.0	4.8	5.6	6.4
Header Tail Length (mm)	EFFECTIVE REAR SIDE MATING LENGTH WITH 4.4 mm SHROUD						
* 4.30							
12.20	6.20	5.40					
12.45	6.45	5.65					
12.95	6.95	6.15	5.35				
* 13.60	7.60	6.80	6.00	5.20			
14.45		7.65	6.85	6.05	5.25		
14.70		7.90	7.10	6.30	5.50		
15.00			7.40	6.60	5.80	5.00	
15.20			7.60	6.80	6.00	5.20	
15.70				7.30	6.50	5.70	
16.40				8.00	7.20	6.40	5.60
* 17.00					7.80	7.00	6.20
17.80						7.80	7.00

* -- Denotes standard length pins.

NUMBER BUS-20-073	TYPE APPLICATION SPECIFICATION	Amphenol FCI	
TITLE Application Guide for Converged Metral™ Vertical Press Fit Signal Headers and Shrouds		PAGE 9 of 23	REVISION F
		AUTHORIZED BY S. ALOSIOUS	DATE 2018-01-08
CLASSIFICATION UNRESTRICTED			

Table 8 - Rear side pin lengths with a 6.9 mm shroud with various board thickness'.

PCB Thickness (mm)	1.6	2.4	3.2	4.0	4.8	5.6	6.4
Header Tail Length (mm)	EFFECTIVE REAR SIDE MATING LENGTH WITH 6.9 mm SHROUD						
* 4.30							
12.20							
12.45							
12.95							
* 13.60	5.10						
14.45	5.95	5.15					
14.70	6.20	5.40					
15.00	6.50	5.70					
15.20	6.70	5.90	5.10				
15.70	7.20	6.40	5.60				
16.40	7.90	7.10	6.30	5.50			
* 17.00		7.70	6.90	6.10	5.30		
17.80			7.70	6.90	6.10	5.30	

* -- Denotes standard length pins.

- Press-fit Headers Retention and Insertion Forces

- The maximum insertion force required to press a header into the PCB is 65 N/pin (14.6 lbf/pin). For example, part number 70232, which has a 4 x 6 pin matrix, has a maximum insertion force of 1560 N (350.7 lbf) (65 N/pin * 24 pins).
- The minimum retention force required for a press fit header is 20 N/pin (4.5lbf). For example, part number 70232 has a minimum retention force of 480 N (108 lbf) (20 N/pin * 24 pins).
- These forces also apply when a pin is being reworked. A rework of a pin occurs when one or more pin(s) are found to be damaged. The damaged pin(s) are then removed and replaced with the appropriate replacement pins. Remove pins from a spare header assembly of the same product number to use for replacing damaged pins. This process may be performed twice.

Table 9 – This table has been removed.

NUMBER BUS-20-073	TYPE APPLICATION SPECIFICATION	Amphenol FCI	
TITLE Application Guide for Converged Metral™ Vertical Press Fit Signal Headers and Shrouds		PAGE 10 of 23	REVISION F
		AUTHORIZED BY S. ALOSIOUS	DATE 2018-01-08
CLASSIFICATION UNRESTRICTED			

- Shroud Retention and Insertion Forces
 - The maximum insertion force required to press a shroud onto the rear side pins of a header is 11 N/pin (2.47 lbf/pin). For example, part number 70203-1Y1, which has a 4 x 6 pin matrix, has a maximum insertion force of 264 N (59.35 lbf) (11 N/pin * 24 pins).
 - The minimum retention force required for a shroud is 2 N/pin (0.45 lbf). For example, part number 70203-1Y1 has a minimum retention force of 48 N (10.8 lbf) (2 N/pin * 24 pins).

4.4 **Materials**

- Housing material is 30% glass filled LCP (Liquid Crystal Polymer). It has an oxygen index of 38. The masses for individual headers are listed in Table 10.
- Pins are made out of Phosphor Bronze.
- The mating area on the pin can be plated with gold or GXT. Refer to Table 2 for the various plating options.

Table 10 - Mass for vertical signal headers.

VERT. Signal Headers	4 x 6	4 x 12	4 x 24	4 x 48
Housing (plastic)	1.21	2.42	4.84	9.68
Total Ass'y W/ 5 mm STUB PIN (-X11)	1.96	3.93	7.85	15.7
Total Ass'y W/ 5 mm RPU PIN (-X21)	2.42	4.85	9.69	19.38
	5 x 6	5 x 12	5 x 24	5 x 48
Housing (plastic)	1.20	2.41	4.81	9.62
Total Ass'y W/ 5 mm STUB PIN (-X11)	2.14	4.29	8.57	17.14
Total Ass'y W/ 5 mm RPU PIN (-X21)	2.72	5.44	10.87	21.74

NUMBER BUS-20-073	TYPE APPLICATION SPECIFICATION	Amphenol FCI	
TITLE Application Guide for Converged Metral™ Vertical Press Fit Signal Headers and Shrouds		PAGE 11 of 23	REVISION F
		AUTHORIZED BY S. ALOSIOUS	DATE 2018-01-08
CLASSIFICATION UNRESTRICTED			

4.5 PCB Requirements

A press fit connection is a means of terminating connectors to printed circuit boards without a soldering operation. The features that are important to define on the printed circuit board when using press fit technology are:

- Drilled hole diameter
- Plated hole diameter
- Plating in thru hole
- Printed circuit board thickness
- Land/pad size

Collectively, these define the reliability of the termination as well as the force required to apply the connector to the printed circuit board. For Metral™, the recommended features are shown in Table 11.

Table 11 - Recommended features for Metral™ PCB.

Feature	Dimension	
	mm	in
Drilled hole diameter	0.81 - 0.86	0.0319 - 0.0339
Recommended drill	0.85	0.0335
Plated hole diameter	0.65 - 0.80	0.0256 - 0.0315
Min. copper plating	0.025	0.00098
Tin/Lead plating (optional)	0.005 - 0.015	0.00019 - 0.00059
Min PCB thickness	1.57 ±10%	0.0618 ±10%
Max PCB thickness	2.4 ±10%	0.0945 ±10%
Land/Pad size	1.17	0.0461

- Figure 6 shows the important features of the PCB.
- Refer to Figure 7 for PCB layout.

NUMBER BUS-20-073	TYPE APPLICATION SPECIFICATION	Amphenol FCI	
TITLE Application Guide for Converged Metral™ Vertical Press Fit Signal Headers and Shrouds		PAGE 13 of 23	REVISION F
		AUTHORIZED BY S. ALOSIOUS	DATE 2018-01-08
		CLASSIFICATION UNRESTRICTED	

4.6 Customer Design Considerations

- Headers should be placed on 12 mm (0.472 in.) increments within a slot (to be consistent with the preferred module placement on the daughtercard); if 12 mm (0.472 in.) increments are not possible, headers should be placed on multiples of 2 mm (0.0787 in.) within a slot.
- Keep outside walls of the headers a minimum of 4 mm (0.157 in.) from any edge of the backpanel to avoid handling and shipping damage.
- In applications that require additional components to be mounted from the non-component side, a minimum slot spacing of 22 mm (0.866 in.) is preferred, when possible, to facilitate fixturing.
- It is recommended that the number of different pin lengths be limited to a maximum of four. Additional lengths may be used, but due to the increase in assembly time, the cost of the product may rise.

4.7 CAM's

4.7.1 Header Insertion Tooling

In order to insert the Metral 4 Row Signal Pin Vertical Headers, without Shorting Clips, two pieces of top tooling are required:

- Press block holder
- Press block

There is also an optional bottom tool (pcb support). Most users develop their own bottom tool (pcb support).

Metral™ headers are sold in 12 mm modules. The following are standard module sizes:

	4 Row Pin Grid	5 Row Pin Grid
1 Module (12 mm)	4 X 6	5 X 6
2 Module (24 mm)	4 X 12	5 X 12
4 Module (48 mm)	4 X 24	5 X 24
8 Module (96 mm)	4 X 48	5 X 48

Some larger module monoblocks are also available.

4 AND 5 ROW PRESS BLOCK HOLDER:

415446-001 THRU -021

A -001 holder is one 12 mm module and A -021 is a 21 12 mm module holder.

4 ROW PRESS BLOCK:

<u>416391-001</u>	1- 12 mm Module (4 X 6)
<u>416391-002</u>	1- 24 mm Module (4 X 12)
<u>416391-003</u>	1- 48 mm Module (4 X 24)
<u>416391-004</u>	1- 96 mm Module (4 X 48)

5 ROW PRESS BLOCK:

<u>430072-001</u>	1- 12 mm Module (5 X 6)
<u>430072-002</u>	1- 24 mm Module (5 X 12)
<u>430072-003</u>	1- 48 mm Module (5 X 24)
<u>430072-004</u>	1- 96 mm Module (5 X 48)

NUMBER BUS-20-073	TYPE APPLICATION SPECIFICATION	Amphenol FCI	
TITLE Application Guide for Converged Metral™ Vertical Press Fit Signal Headers and Shrouds		PAGE 14 of 23	REVISION F
		AUTHORIZED BY S. ALOSIOUS	DATE 2018-01-08
CLASSIFICATION UNRESTRICTED			

4 AND 5 ROW BOARD SUPPORT:

415609-001 1- 12 mm Module

415609-002 1- 24 mm Module

415609-003 1- 48 mm Module

415609-004 1- 96 mm Module

To order the correct tooling simply match the number of connector modules to the corresponding number of press block modules and a holder that is large enough to hold the total of the press blocks.

IT IS IMPORTANT TO NOTE THAT YOU CAN MIX SIGNAL AND POWER PRESS BLOCKS IN THE SAME HOLDER. YOU ALSO USE THE SAME HOLDER FOR 4 AND 5 ROW PRESS BLOCKS.

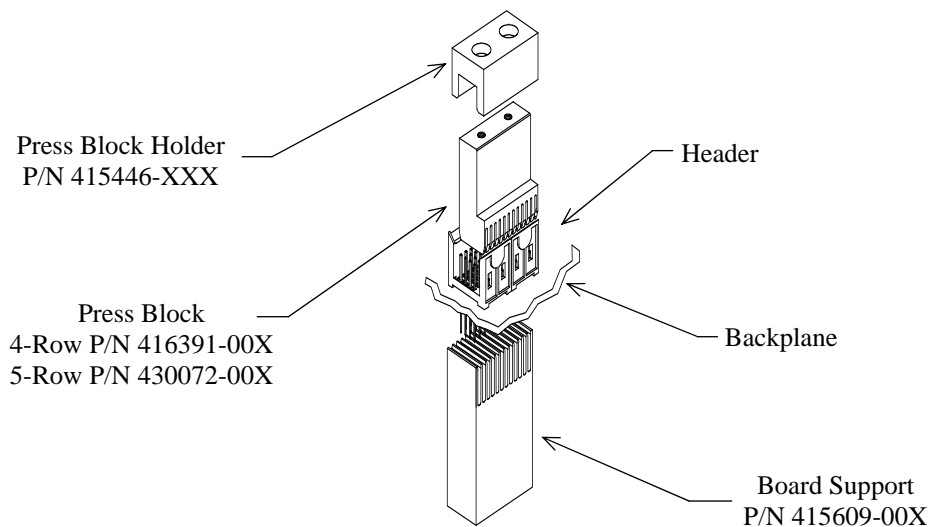

4.7.2 Header Removal Tooling

There are numerous tools available to remove either single or multiple pins.

SINGLE PIN REMOVAL TOOLS:

MT-330 P/N 194208-001

This tool is used to push single signal pins out from the backside of the board.

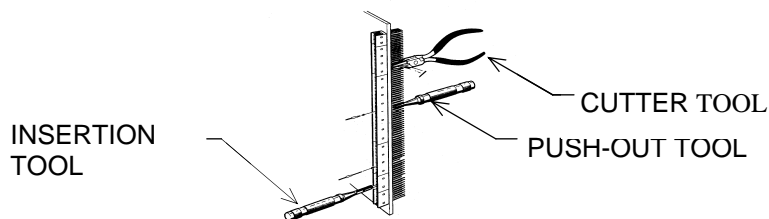

NUMBER BUS-20-073	TYPE APPLICATION SPECIFICATION	Amphenol FCI	
TITLE Application Guide for Converged Metral™ Vertical Press Fit Signal Headers and Shrouds		PAGE 15 of 23	REVISION F
		AUTHORIZED BY S. ALOSIUS	DATE 2018-01-08
CLASSIFICATION UNRESTRICTED			

MT-340 P/N 194204-001

This tool is used to pull single signal pins out from the mating side of the connector.

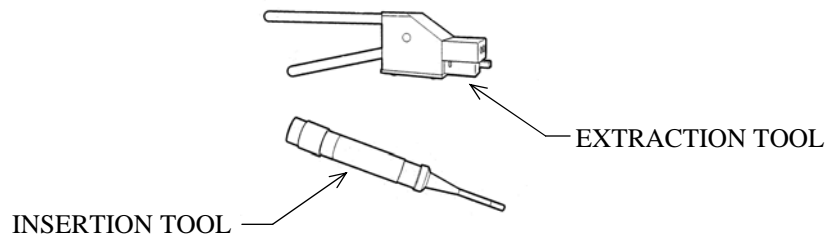

MT370-01 P/N MT370-01

This is a shelf level repair kit that has tools to remove single pins (power or signal) when the board is in a rack. It can also be used when the board is not in a rack. It also contains tools to remove single (12 mm) module housings from the pins.

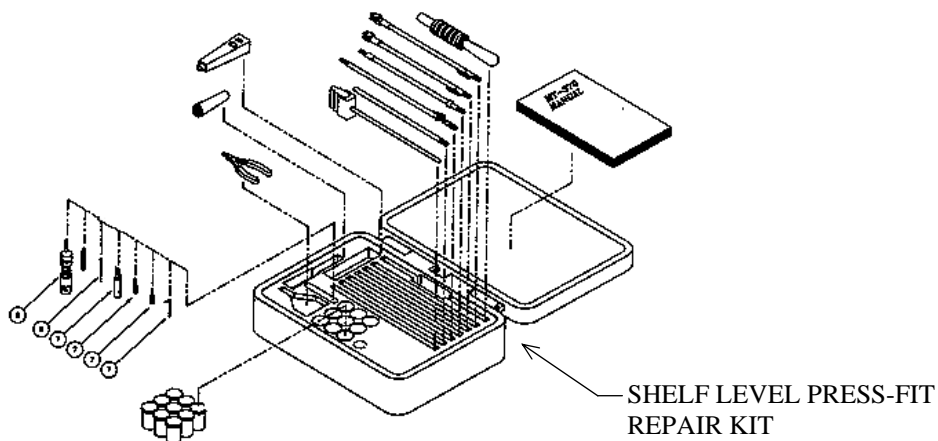

NUMBER BUS-20-073	TYPE APPLICATION SPECIFICATION	Amphenol FCI	
TITLE Application Guide for Converged Metral™ Vertical Press Fit Signal Headers and Shrouds		PAGE 16 of 23	REVISION F
		AUTHORIZED BY S. ALOSIOUS	DATE 2018-01-08
CLASSIFICATION UNRESTRICTED			

MULTIPLE PIN REMOVAL TOOLS

The 4x6 and 5x6 pin removal tool kits are hand tools used to remove Metral signal pins from the tail side of the circuit board. A hand operated arbor press, not included, is required to actuate the hand tool. The 4x6-grid tool kit removes 4 columns by 6 rows and the 5x6 grid tool kit removes 5 columns by 6 rows of pin at one time. The connector removal pliers assist in separating the connector from the PCB.

Product Style	Hole Pattern	For Boards Thinner Than .093"		For Boards Thicker Than .093"	
4 row	4 x 6 Grid	HT-0531	415878-001	HT-0531A	415878-003
5 row standard	5 x 6 Grid	HT-0532	415878-002	HT-0532A	415878-004

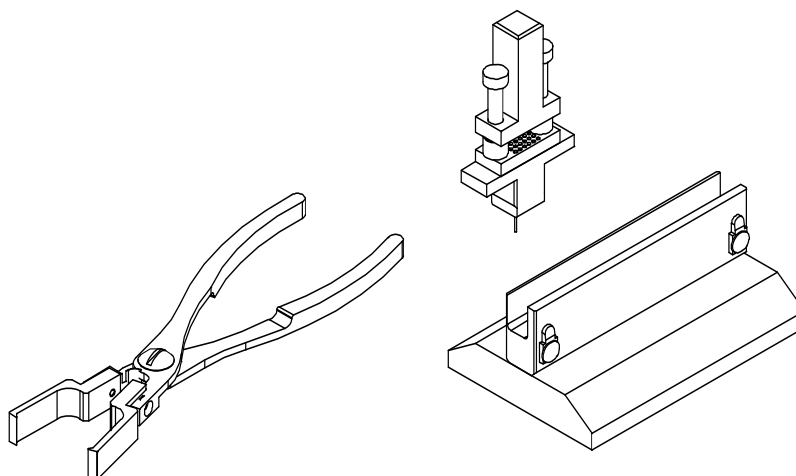

4.7.3 Shroud Insertion Tooling

In order to insert the Metral 4 and 5 row shroud, two pieces of tooling are required:

- Press Block
- A Bottom Tool (Board Support)

In order to insert a shroud, a header must have first been inserted on the opposite side of the board. The header insertion tool can be used as a board support while applying the shroud.

NUMBER BUS-20-073	TYPE APPLICATION SPECIFICATION	Amphenol FCI	
TITLE Application Guide for Converged Metral™ Vertical Press Fit Signal Headers and Shrouds		PAGE 17 of 23	REVISION F
		AUTHORIZED BY S. ALOSIOUS	DATE 2018-01-08
CLASSIFICATION UNRESTRICTED			

Insertion Tool Part Number	4 ROW	5 ROW	Qty. of 12 mm Modules
	166623-001	166624-001	8
	166623-002	166624-002	4
	166623-003	166624-003	2
	166623-004	166624-004	3
	166623-005	166624-005	5
	166623-006	166624-006	6
	166623-007	166624-007	7
	166623-009	166624-009	9
	166623-010	166624-010	10
	166623-011	166624-011	11
	166623-012	166624-012	12
	166623-013	166624-013	13
	166623-014	166624-014	14
	166623-015	166624-015	15
	166623-016	166624-016	16
	166623-017	166624-017	17
	166623-018	166624-018	18
	166623-019	166624-019	19
	166623-020	166624-020	20

NOTE: If you change the first digit of the dash number from a "0" to a "5" the insertion tool will come with three threaded holes on top so that can be mounted to another piece of tooling if desired.

4.7.4 Shroud Removal Tooling

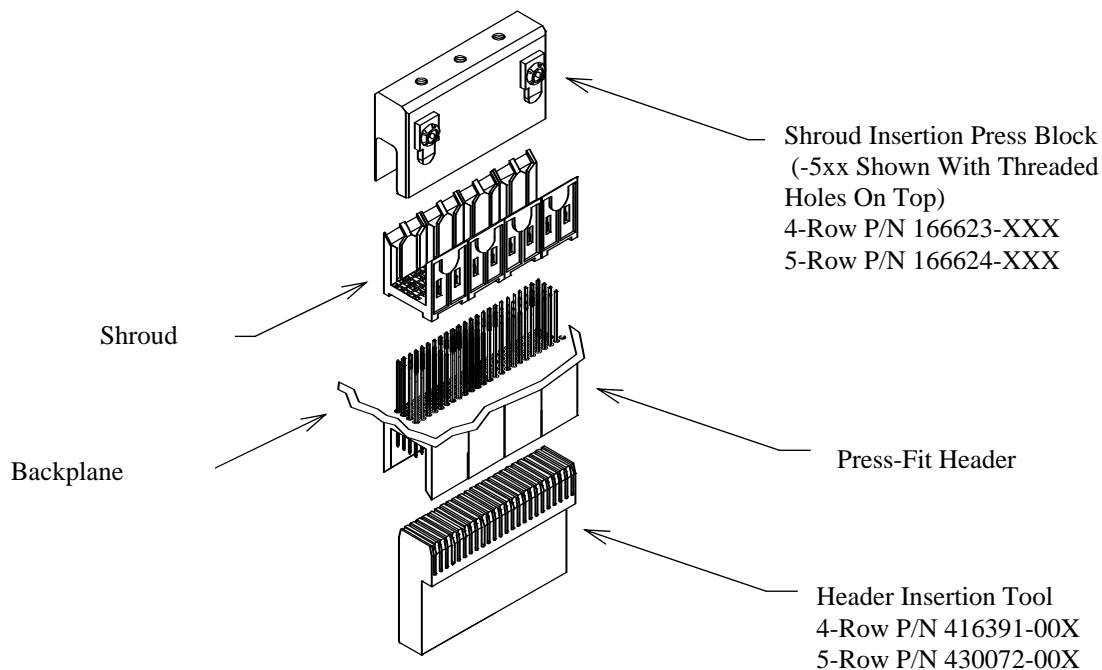

NUMBER BUS-20-073	TYPE APPLICATION SPECIFICATION	Amphenol FCI	
TITLE Application Guide for Converged Metral™ Vertical Press Fit Signal Headers and Shrouds		PAGE 18 of 23	REVISION F
		AUTHORIZED BY S. ALOSIOUS	DATE 2018-01-08
CLASSIFICATION UNRESTRICTED			

HT-0533 P/N 415923-XXX 4 Row pneumatic shroud removal tool

- 415923-001 1 Module
- 415923-002 2 Module
- 415923-003 3 Module
- 415923-004 4 Module
- 415923-008 8 Module

HT-0534 P/N 415922-XXX 5 Row pneumatic shroud removal tool

- 415922-001 1 Module
- 415922-002 2 Module
- 415922-003 3 Module
- 415922-004 4 Module
- 415922-008 8 Module

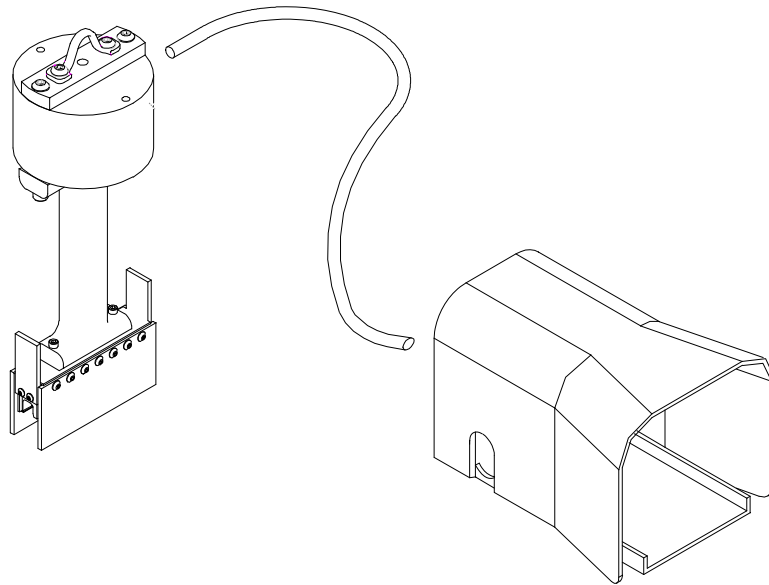

NUMBER BUS-20-073	TYPE APPLICATION SPECIFICATION	Amphenol FCI	
TITLE Application Guide for Converged Metral™ Vertical Press Fit Signal Headers and Shrouds		PAGE 19 of 23	REVISION F
		AUTHORIZED BY S. ALOSIOUS	DATE 2018-01-08
CLASSIFICATION UNRESTRICTED			

4.7.5 Presses

Metral vertical press fit headers can be installed with any standard press as long as it has enough force to properly install the number of pins that are being installed.

In addition, FCI offers a couple of presses that can be used.

MT-301 HANDPRESS P/N 194205-002

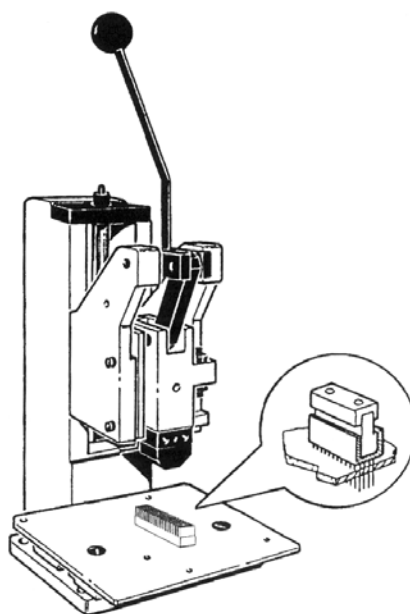

Impress Press

FCI manufactures a complete line of servo-driven electric presses to install all press fit connectors. The Impress line of presses range from a manual placement, operator actuated press to a fully automated pick, place, and press unit. The entire line up of machine features includes state of the art electronic press controls with a closed loop feedback system. Contact your local sales representative for additional information on the Impress line of presses.

NUMBER BUS-20-073	TYPE APPLICATION SPECIFICATION	Amphenol FCI	
TITLE Application Guide for Converged Metral™ Vertical Press Fit Signal Headers and Shrouds		PAGE 20 of 23	REVISION F
		AUTHORIZED BY S. ALOSIOUS	DATE 2018-01-08
CLASSIFICATION UNRESTRICTED			

4.8 Order Forms

Table 12 - Order sheet for 4 row select load vertical press fit signal headers.

4 row
Base PN:

ROW	COL. 1	COL. 2	COL. 3	COL. 4	COL. 5	COL. 6	COL. 7	COL. 8	COL. 9	COL. 10	COL. 11	COL. 12
D												
C												
B												
A												

ROW	COL. 13	COL. 14	COL. 15	COL. 16	COL. 17	COL. 18	COL. 19	COL. 20	COL. 21	COL. 22	COL. 23	COL. 24
D												
C												
B												
A												

ROW	COL. 25	COL. 26	COL. 27	COL. 28	COL. 29	COL. 30	COL. 31	COL. 32	COL. 33	COL. 34	COL. 35	COL. 36
D												
C												
B												
A												

ROW	COL. 37	COL. 38	COL. 39	COL. 40	COL. 41	COL. 42	COL. 43	COL. 44	COL. 45	COL. 46	COL. 47	COL. 48
D												
C												
B												
A												

ROW	COL. 49	COL. 50	COL. 51	COL. 52	COL. 53	COL. 54	COL. 55	COL. 56	COL. 57
D									
C									
B									
A									

ROW	COL. 58	COL. 59	COL. 60	COL. 61	COL. 62	COL. 63	COL. 64	COL. 65	COL. 66
D									
C									
B									
A									

Standard Pins

CODE	Mating Side	RPU
01	5.00	4.30
02	5.75	4.30
03	6.50	4.30
04	7.25	4.30
05	5.00	13.60
06	5.75	13.60
07	6.50	13.60
08	7.25	13.60
09	5.00	17.00
10	5.75	17.00
11	6.50	17.00
12	7.25	17.00
13	8.25	4.30
14	8.25	13.60
15	8.25	17.00
16	7.00	4.30
17	7.00	13.60
18	7.00	17.00
19	8.00	4.30
20	8.00	13.60
21	8.00	17.00

For additional pin lengths, contact your local sales rep.

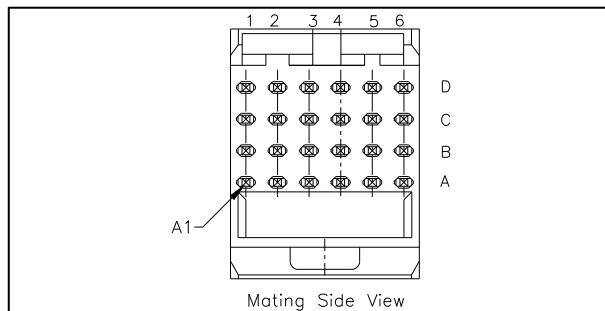

NUMBER BUS-20-073	TYPE APPLICATION SPECIFICATION	Amphenol FCI	
TITLE Application Guide for Converged Metral™ Vertical Press Fit Signal Headers and Shrouds		PAGE 21 of 23	REVISION F
		AUTHORIZED BY S. ALOSIOUS	DATE 2018-01-08
CLASSIFICATION UNRESTRICTED			

Table 13 - Order sheet for 5 row select load vertical press fit signal headers.

5 row
Base PN:

ROW	COL. 1	COL. 2	COL. 3	COL. 4	COL. 5	COL. 6	COL. 7	COL. 8	COL. 9	COL. 10	COL. 11	COL. 12
E												
D												
C												
B												
A												

ROW	COL. 13	COL. 14	COL. 15	COL. 16	COL. 17	COL. 18	COL. 19	COL. 20	COL. 21	COL. 22	COL. 23	COL. 24
E												
D												
C												
B												
A												

ROW	COL. 25	COL. 26	COL. 27	COL. 28	COL. 29	COL. 30	COL. 31	COL. 32	COL. 33	COL. 34	COL. 35	COL. 36
E												
D												
C												
B												
A												

ROW	COL. 37	COL. 38	COL. 39	COL. 40	COL. 41	COL. 42	COL. 43	COL. 44	COL. 45	COL. 46	COL. 47	COL. 48
E												
D												
C												
B												
A												

ROW	COL. 49	COL. 50	COL. 51	COL. 52	COL. 53	COL. 54	COL. 55	COL. 56	COL. 57
E									
D									
C									
B									
A									

ROW	COL. 58	COL. 59	COL. 60	COL. 61	COL. 62	COL. 63	COL. 64	COL. 65	COL. 66
E									
D									
C									
B									
A									

Standard Pins

CODE	Mating Side	RPU
01	5.00	4.30
02	5.75	4.30
03	6.50	4.30
04	7.25	4.30
05	5.00	13.60
06	5.75	13.60
07	6.50	13.60
08	7.25	13.60
09	5.00	17.00
10	5.75	17.00
11	6.50	17.00
12	7.25	17.00
13	8.25	4.30
14	8.25	13.60
15	8.25	17.00
16	7.00	4.30
17	7.00	13.60
18	7.00	17.00
19	8.00	4.30
20	8.00	13.60
21	8.00	17.00

For additional pin lengths, contact your local sales rep.

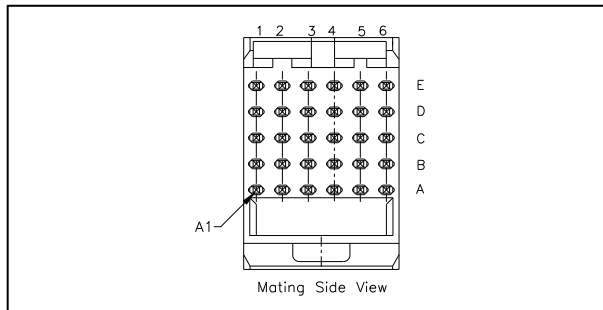

NUMBER BUS-20-073	TYPE APPLICATION SPECIFICATION	Amphenol FCI	
TITLE Application Guide for Converged Metral™ Vertical Press Fit Signal Headers and Shrouds		PAGE 22 of 23	REVISION F
		AUTHORIZED BY S. ALOSIOUS	DATE 2018-01-08
CLASSIFICATION UNRESTRICTED			

5.0 REFERENCE DOCUMENTS

Any applicable product prints.
GS-12-002 -- Metral™ Connector System
GS-12-004 -- Specification for Metral™ Compliant Contacts

6.0 RECORD RETENTION – N/A

NUMBER BUS-20-073	TYPE APPLICATION SPECIFICATION	Amphenol FCI	
TITLE Application Guide for Converged Metral™ Vertical Press Fit Signal Headers and Shrouds		PAGE 23 of 23	REVISION F
		AUTHORIZED BY S. ALOSIUS	DATE 2018-01-08
CLASSIFICATION UNRESTRICTED			

REVISION RECORD

REV	PAGE	DESCRIPTION	EC #	DATE
A	All	New Release	V10043	02/05/01
B	All	Change to generic plating specifications	V04-0611	06/08/04
C	All	Add lead free information	V05-0931	10/03/05
D	All	Change logo	V06-0405	04/26/06
E	9 & 10	Revise replacement pin instructions, remove Table 9.	V08-0239	06/02/08
F	9 & 10	Modified the PCB insertion and retention force values and removed the typical values	ECN-ELX- I - 28982-1	01/16/18