



## D-Sub Pressfit Connectors

Amphenol’s FCI D-Sub connectors are part of an industry standard for applications requiring robust and reliable connectors. These proven D-Sub connectors are one of the most popular Input/Output interconnects, addressing a wide variety of applications in Telecommunications, Data, Consumer Industrial, Military, Instrumentation and Medical. Since many years Amphenol FCI has been offering a wide range of D-Sub connectors to meet various design requirements including those in harsh environment.

Amphenol offers Standard density and Mixed power connectors in press fit termination. In SMT (Surface Mount Technology) manufacturing process, this Press-fit series connectors help to save the cost of an additional wave soldering. The “eye of the needle” termination combined with a special flat rock design (easy application by pressure on insulator) make this product line very attractive.



### TARGET MARKETS



### FEATURES

- Connectors are press-fitted into the PCB
- Flat rock contact design
- Eye of the needle termination
- Same connectors are compatible with PCB thicknesses of 1.6mm and 2.4mm
- Solder less board locking
- Press-fit boardlocks

### BENEFITS

- Saves wave soldering cost
- Easy to mount
- Ensures retention in PCB
- Flexibility in application
- Solder less grounding
- Provides additional mechanical strength

# RIGHT ANGLE PRESS FIT

**UL** <sup>®</sup> UL RECOGNISED FILE E66906



## ORDERING INFORMATION

<b>D</b>	<b>25</b>	<b>P</b>	<b>82C</b>	<b>4</b>	<b>PA</b>	<b>00LF</b>
----------	-----------	----------	------------	----------	-----------	-------------

Series:

Number of Contacts	
09	
15	
25	
37	
50*	

Contacts	
Pin	P
Socket	S

Durability	
Standard class (≥200 mating/unmating)	4
High performance class (≥500 mating/unmating)	6

RoHS Status	
Standard, RoHS compatible	00LF ✓

Mounting Options	
Standard hole	PA
Threaded insert M3	PL
Threaded insert UNC 4-40	PX ✓
Female screw UNC 4-40	PV ✓
Harpoons + insert M3	GL
Harpoons + insert UNC 4-40	GX
Harpoons + female screw UNC 4-40	GV

Termination		
Type	Footprint/Pitch	Code
Eurostyle	9.4/2.54 – 9 to 37 way 10.3/2.54 – 50 way	82C ✓
US standard	8.08/2.84 – 9 to 37 way	80C
Europe standard*	10.4/2.54 – 9 to 37 way	81C

\*Only for Eurostyle version Preferred Option ✓

## ▶ D-Sub Pressfit Connectors

### SPECIFIC DIMENSIONS

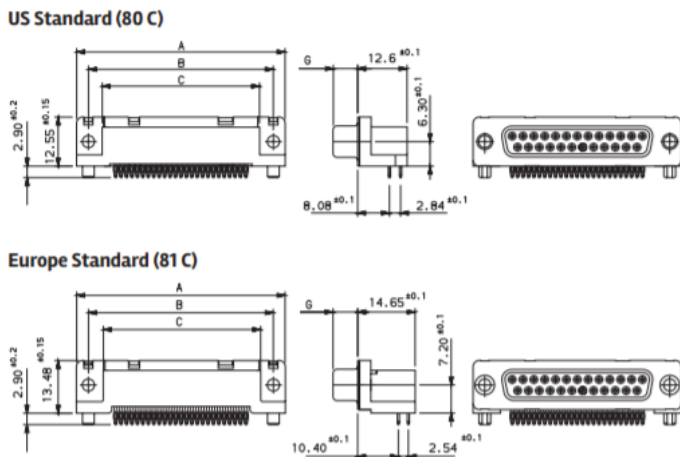
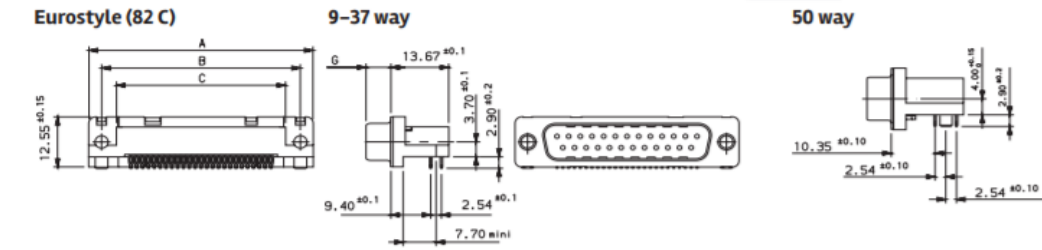

		A±0.38	B±0.12	C±0.10	G-0/+0.25
09	P	30.81	24.99	16.96	5.90 -0/+0.15
	S	30.81	24.99	16.96	6.05
15	P	39.14	33.32	25.18	5.90 -0/+0.15
	S	39.14	33.32	25.18	6.05
27	P	53.03	47.04	39.12	5.70
	S	53.03	47.04	39.12	6.05
37	P	69.32	63.50	55.68	5.70
	S	69.32	63.50	55.68	6.05
50*	P	67.10	61.11	54.10	5.70
	S	67.10	61.11	54.10	6.05

\*Only for Eurostyle version Preferred Option

### SPECIFIC DIMENSIONS

- Application by pressure on insulator
- D-Sub insertion kit: 8646 3064 01
- Eye of the needle design

### METALLIZED HOLE DIMENSIONS

		Press-fit Contacts	Press-fit Harpoons
PCB hole definition (note 1 and 2)		Drill diameter	∅ 1.15 ref (note 3)
		Drilled hole	∅ 1.18 - 1.2
		Copper plating	25µm min. (recommended 50µ max.)
	non RoHS	Tin-lead plating	15µm max. (recommended 5µ min.)
		Finish hole (after reflow)	∅ 0.94 - 1.09
		RoHS	Tin plating
	Finish hole (after reflow)	∅ 1.00 - 1.09	
		∅ 3.08 - 3.20	

Note 1: These dimensions must be respected to ensure press-fit pin performance

Note 2: According to IEC-352-S specification

Note 3: Vital requirement for press-fit pin performance

### PRESS-FIT PERFORMANCE

	Press-fit Contacts	Press-fit Harpoons
Insertion force	≤100 N	≤120 N
Extraction force	≥30 N	≥30 N

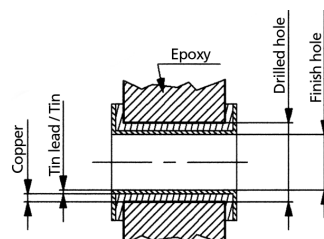

## ▶ D-Sub Pressfit Connectors

# STRAIGHT PRESS-FIT



- This new Press-fit connectors eliminate soldering process and saves cost
- Compatible with PCB thicknesses of 1.60 mm & 2.40 mm
- The “eye of the needle” termination combined with a special flat rock design (easy application by pressure on insulator) make this product line very attractive



## ORDERING INFORMATION

<b>D</b>	<b>25</b>	<b>P</b>	<b>91C</b>	<b>4</b>	<b>PA</b>	<b>00LF</b>	RoHS Status	
Series							Standard, RoHS compatible	00LF ✓
Number of Contacts						Mounting Options		
09						Standard hole	PA	
15						Threaded insert M3	PL	
25						Threaded insert UNC 4-40	PX ✓	
37						Female screw UNC 4-40	PV ✓	
50						Harpoons + insert M3 + elec. continuity	GL	
						Harpoons + insert UNC 4-40 + elec. continuity	GX	
						Harpoons + female screw UNC 4-40 + elec. continuity	GV	
		Contacts		Durability				
		Pin P		Standard class ≥200 mating/ unmating		4		
		Socket S		High performance mating/unmating)		6		
Termination Type								
Type							Code	
Press-fit suitable for PCB thickness 1.6mm & 2.4mm - Europe Standard							91C	
Press-fit suitable for PCB thickness 1.6mm & 2.4mm - Low Profile							90C	

Preferred Option ✓

## ► D-Sub Pressfit Connectors

### SPECIFIC DIMENSIONS

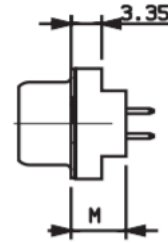
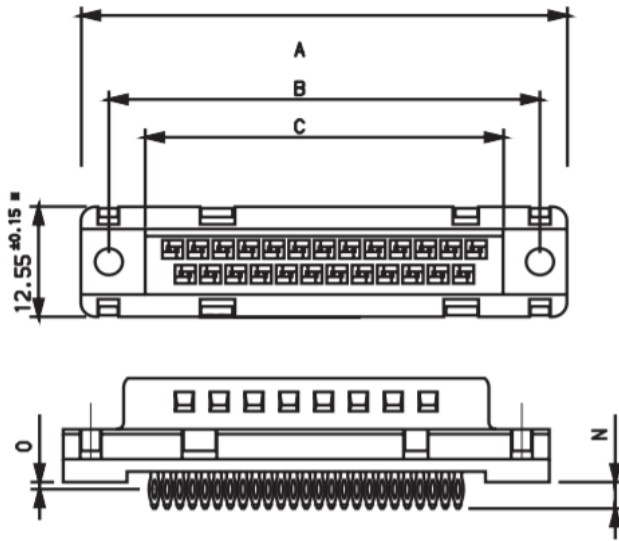

\*For 50 contacts: 15.34 ± 0.15  
For other dimensions, consult us

Size	A $\pm 0.38$	B $\pm 0.12$	C $\pm 0.10$
09	30.81	24.99	16.96
15	39.14	33.32	25.18
25	53.03	47.04	39.12
37	69.32	63.50	55.68
50	66.93	61.11	53.11

Termination Type	M $\pm 0.3$	N $\pm 0.3$	O $\pm 0.2$
90C	5.60	3.40	1.20
91C	6.00	3.00	0.80

### PRESS-FIT FEATURES

- Application by pressure on insulator
- D-Sub insertion kit: 8646 3064 01
- Eye of the needle design

### METALLIZED HOLE DIMENSIONS

		Press-fit Contacts	Press-fit Harpoons
P.C.B hole definition (note 1 and 2)		Drill diameter	Ø 1.15 ref (note 3)
		Drilled hole	Ø 1.18 - 1.2
		Copper plating	25µm min. (recommended 50µ max.)
	non RoHS	Tin-lead plating	15µm max. (recommended 5µ min.)
		Finish hole (after reflow)	Ø 0.94 - 1.09
	RoHS	Tin plating	0.8 to 1.2µm
Finish hole (after reflow)		Ø 1.00 - 1.09	

Note 1: These dimensions must be respected to ensure press-fit pin performance

Note 2: According to IEC-352-S specification

Note 3: Vital requirement for press-fit pin performance

### PRESS-FIT PERFORMANCE

	Press-fit Contacts	Press-fit Harpoons
Insertion force	≤100 N	≤120 N
Extraction force	≥30 N	≥30 N

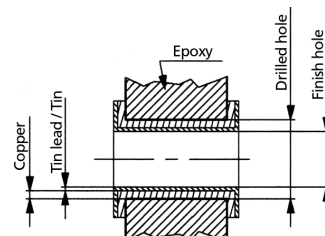

# ▶ D-Sub Pressfit Connectors

## FULL POWER RIGHT ANGLE AND STRAIGHT PRESS-FIT

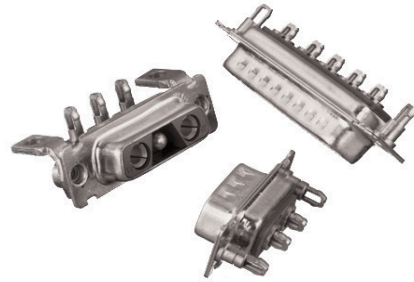

### ORDERING INFORMATION

<b>D</b>	<b>E</b>	<b>L</b>	<b>2</b>	<b>V</b>	<b>2</b>	<b>P</b>	<b>93C</b>	<b>5</b>	<b>G</b>	<b>40LF</b>			
Series	Shell Size (tin plated): E, A, B, C		2	V	2								
			3	V	3								
			3	W	3								
			5	W	5								
			8	W	8								
Front Accessory			Layouts			Contacts		Power Contacts					
	Blank	L	O	I	V	Pin	P	Fitted with power contacts 30A RoHS compatible		30LF			
Straight version		X	X		X	Socket	S	Fitted with power contacts 40A RoHS compatible		40LF			
Right angled	X	X	X		X	Termination Type		PCB Accessory					
						Straight version		M			G	A	
						Right angled / Europe standard		Straight version				X	
						Right angled / US standard (5W1, 9W4 non available)		Right angled			X		X
						Durability		X: Available			A: Without accessory		
						200 mating/unmating		G: Harpoon used for PCB thickness from 1.6mm			M: Metal brackets without harpoon		
						500 mating/unmating		M			A		
								G			M		

X: Available  
 Blank: without accessory  
 L: Threaded insert M3  
 O: Threaded insert UNC 4-40  
 I: Female screw UNC M3  
 V: Female screw UNC 4-40



## ► D-Sub Pressfit Connectors

### SPECIFIC DIMENSIONS

#### METALIZED HOLE DIMENSIONS

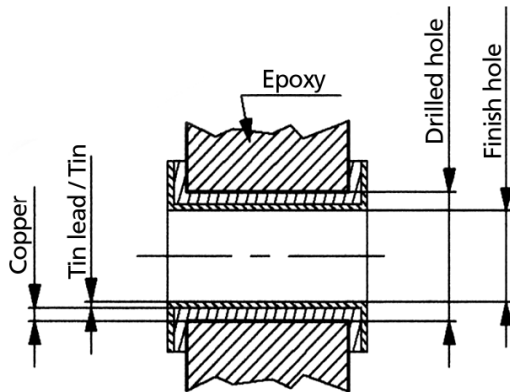

Termination Type		Press-fit Contacts	Press-fit Harpoons		
P.C.B hole definition (note 1 and 2)		Drill diameter	$\varnothing 3.22^{\pm 0.03}$	$\varnothing 3.22^{\pm 0.03}$	$\varnothing 3.22^{\pm 0.03}$
		Drilled hole	$\varnothing 3.19 - 3.25$	$\varnothing 3.19 - 3.25$	
		Copper plating	25 $\mu$ m min. (recommended 50 $\mu$ max.)	25 $\mu$ m min. (recommended 50 $\mu$ max.)	
	non RoHS	Tin-lead plating	15 $\mu$ m max. (recommended 5 $\mu$ min.)	15 $\mu$ m max. (recommended 5 $\mu$ min.)	
		Finish hole (after reflow)	$\varnothing 3.02 - 3.20$	$\varnothing 3.02 - 3.20$	
	RoHS	Tin plating	0.8 to 1.2 $\mu$ m	0.8 to 1.2 $\mu$ m	
		Finish hole (after reflow)	$\varnothing 3.08 - 3.20$	$\varnothing 3.08 - 3.20$	

Note 1: These dimensions must be respected to ensure press-fit pin performance

Note 2: According to IEC-352-S specification

Note 3: Vital requirement for press-fit pin performance

#### PRESS-FIT PERFORMANCE

	Press-fit Contacts	Press-fit Harpoons
Insertion force	$\leq 200$ N (average insertion 160 N)	$\leq 200$ N (average insertion 160 N)
Extraction force	$\geq 30$ N	$\geq 30$ N

## ▶ D-Sub Pressfit Connectors

# TECHNICAL INFORMATION

### PHYSICAL CHARACTERISTICS

- Insulator Material: PBT color Black
- Contact Material: Phosphor Bronze
- Grounding Device Material: Brass
- Accessories: Brass

### ELECTRICAL CHARACTERISTICS

- Maximum Rating Current: 5A at 20°C / 2.5A at 70°C
- Nominal Current: 5A (Standard conditions)
- Contact Resistance:
  - Straight terminations: <10mΩ
  - Right Angled Termination:
    - <25mΩ for 9 To 37 way
    - <35mΩ for 50 way
- Voltage Proof: >1000 V.r.m.s.
- Rated Voltage: 300 V.r.m.s.
- Insulation Resistance: >5000mΩ
- Creepage and Clearance Distance: >1mm
- Average Wiping Length: 2mm

### MECHANICAL CHARACTERISTICS

- RETENTION AGAINST TORQUE:
  - Threaded insert: 0.7 N.m max. from front side
  - Threaded insert: 0.3 N.m max. from rear side  
0.25N.m min. from rear side
  - Insert L: Threaded M3
  - Insert X: Threaded UNC 4.40
  - Female Screw Lock: 0.5 N.m max. from front side
  - Female Screw V Threaded UNC 4.40
  - Female Screw I Threaded M3
- Insertion and Withdrawal Force: <n x 3.40 N (n number of cts)
- Gauge Retention Force: >0.20N (Gauge PM)
- Thickness Gauge Ø: 0.99±0.005 / Surface Roughness: Ra=0.10µ  
mini- 0.25µ maxi
- Contact Retention In Insulator:
  - Mini 16N for straight contact
  - Mini 20N for right angled contact
- Vibrations: 10-2000Hz / 1.5 mm - 20g /3 x 2 HRS
- Interruption: <1µs (Not applicable for PL3)
- Shock: ACC. HALF SINE 50g- 11m.s-6x3 Shocks
- Interruption: <1µs

### PACKAGING

- Tray & Bulk pack (jack connectors, plug connector components)
- Tape & Reel (right angle Pin-in-Paste jack connectors)
- Single Kit (plug connector components)
- Carton (cable assemblies)

### TARGET MARKETS/APPLICATIONS



Asymmetric Digital Subscriber Line (ADSL)  
Base Station  
Switching  
Transmission



Set-top Box



Desktop and Laptop  
Storage System  
Router and Server



Automotive Diagnostics  
Control Drives  
Energy Meter  
Gaming Machine  
Test Equipment  
Office Automation  
POS & Handheld terminal  
Power Supplies  
Parking Meter  
Printer and Copier  
Renewable Energy  
Robotics  
Surveillance Camera  
Avionics



Medical Instrument



Military Equipment