

## (C)XP-CXX96-40D(A)

### 10Gb/s CWDM SFP+ 40km Transceiver with/without CDR

#### PRODUCT FEATURES

- Up to 11.3Gbps Data Links
- Up to 40km transmission on SMF
- CWDM EML transmitter and PIN receiver
- Metal enclosure for lower EMI
- 2-wire interface with integrated Digital Diagnostic monitoring
- Hot-pluggable SFP+ footprint
- Specifications compliant with SFF 8472
- Compliant with SFP+ MSA with LC connector
- Single 3.3V power supply
- Commercial/Industrial case operating temperature range: 0°C to 70°C /-40°C to 85°C
- Without CDR or with CDR supported 9.95 to 11.3Gb/s reference-free
- Low power dissipation:
  - XP-CXX96-40D:** 1.3W power dissipation without CDR for Commercial temperature
  - XP-CXX96-40DA:** 1.5W power dissipation without CDR for Industrial temperature
  - CXP-CXX96-40D:** 1.4W power dissipation with CDR for Commercial temperature
  - CXP-CXX96-40DA:** 1.6W power dissipation with CDR for Industrial temperature



#### APPLICATIONS

- 10GBASE-ER/EW & 10G Ethernet
- 10G SONET/SDH, OTU2/2e

#### STANDARD

- Compliant to SFF-8431
- Compliant to SFF 8472
- RoHS Compliant.

## Ordering information

Product part Number	Media	Wavelength (nm)	Transmission Distance(km)	Temperature Range (Tcase) (°C)	With/Without CDR
XP-CXX96-40D	Single-mode fiber	Refer to wavelength selection	40	0~70	Without CDR
XP-CXX96-40DA	Single-mode fiber	Refer to wavelength selection	40	-40~85	Without CDR
CXP-CXX96-40D	Single-mode fiber	Refer to wavelength selection	40	0~70	With CDR
CXP-CXX96-40DA	Single-mode fiber	Refer to wavelength selection	40	-40~85	With CDR

## Wavelength selection

(C)XP-CXX96-40D(A):

Wavelength	XX	Clasp Color Code	Wavelength	XX	Clasp Color Code
1470 nm	47	Gray	1550 nm	55	Yellow
1490 nm	49	Purple	1570 nm	57	Orange
1510 nm	51	Blue	1590 nm	59	Red
1530 nm	53	Green	1610 nm	61	Brown

## PRODUCT DESCRIPTION

XGIGA's (C)XP-CXX96-40D(A) serial SFP+ transceiver is designed for use in 10-Gigabit Ethernet links up to 40km over single mode fiber. The module consists of CWDM EML Laser, InGaAs PIN and Preamplifier in a high-integrated optical sub-assembly. Digital diagnostics functions are available via a 2-wire serial interface, as specified in SFF8472. The module data link up to 40km in 9/125um single mode fiber.

## I. Absolute Maximum Ratings

Parameter	Symbol	Min.	Typ.	Max.	Unit	Note
Storage Temperature	Ts	-40	-	85	°C	
Relative Humidity	RH	5	-	95	%	
Power Supply Voltage	VCC	-0.3	-	4	V	
Signal Input Voltage		Vcc-0.3	-	Vcc+0.3	V	

## II. Recommended Operating Conditions

Parameter	Symbol	Min.	Typ.	Max.	Unit	Note
Case Operating Temperature	Top	0	-	70	°C	XP-CXX96-40D CXP-CXX96-40D
		-40		85		XP-CXX96-40DA CXP-CXX96-40DA
Power Supply Voltage	V <sub>CC</sub>	3.14	3.3	3.47	V	
Data Rate	BR		10.3125	11.3	Gbps	
Max transmission Distance	TD		40		km	
Coupled fiber	Single mode fiber					9/125um SMF

## III. Optical Characteristics

Parameter	Symbol	Min.	Typ.	Max.	Unit	Note
<b>Transmitter</b>						
Average Launched Power	PO	-1		+3	dBm	Note (1)
Extinction Ratio	ER	8.2			dB	
Center Wavelength	$\lambda_c$	$\lambda_c - 6.5$		$\lambda_c + 6.5$	nm	Note (2)
Spectrum Band Width (-20dB)	$\sigma$			1.0	nm	
SMSR		30			dB	
Transmitter OFF Output Power	P <sub>off</sub>			-30	dBm	
Transmitter and Dispersion Penalty	TDP			2.0	dB	
Output Eye Mask	Compliant with IEEE 802.3ae					
<b>Receiver</b>						
Input Optical Wavelength	$\lambda$	1270		1610	nm	
Receiver Sensitivity	P <sub>sen</sub>			-16.0	dBm	Note (3)
Input Saturation Power (Overload)	P <sub>sat</sub>	0			dBm	

LOS Assert	LOSA	-30			dBm	
LOS De-assert	LOSD			-17	dBm	
LOS Detect Hysteresis	P <sub>hys</sub>	0.5			dB	

Note:

1. Launched power (avg.) is power coupled into a single mode fiber with master connector. (Before of Life)
2.  $\lambda c$  refer to wavelength selection
3. Measured with conformance test signal for BER =  $10^{-12}$ .@10.3125Gbps, PRBS=2<sup>31</sup>-1,NRZ; Optical source with worst ER, Wavelength between 1470nm and 1610nm; back to back

#### IV. Electrical Characteristics

Parameter	Symbol	Min	Typ	Max	Unit	NOTE
Supply Voltage	V <sub>cc</sub>	3.14	3.3	3.46	V	
Supply Current (Note 1)	I <sub>cc</sub>			400	mA	XP-CXX96-40D
				460		XP- CXX96-40DA
				430		CXP- CXX96-40D
				490		CXP- CXX96-40DA
<b>Transmitter</b>						
Input differential impedance	R <sub>in</sub>		100		Ω	2
Single ended data input swing	V <sub>in-pp</sub>	180		700	mV	
Transmit Disable Voltage	V <sub>Dis</sub>	2.0		V <sub>cc</sub>	V	3
Transmit Enable Voltage	V <sub>EN</sub>	V <sub>ee</sub>		V <sub>ee</sub> + 0.8	V	
Transmit Disable Assert Time				10	us	
<b>Receiver</b>						
Differential data output swing	V <sub>out-pp</sub>	400		800	mV	4
Data output rise time	t <sub>r</sub>	28			ps	5
Data output fall time	t <sub>f</sub>	28			ps	5
LOS output high level	V <sub>LOS-H</sub>	2.0		V <sub>CCHOST</sub>	V	6
LOS output low level	V <sub>LOS-L</sub>	V <sub>ee</sub>		V <sub>ee</sub> +0.8	V	6

**Notes:**

1. Measured with receive Pin=P<sub>sen</sub>, V<sub>cc</sub>=3.3V, operation temperature range, without air flow

2. Connected directly to TX data input pins. AC coupled .
3. Or open circuit.
4. Into 100 ohms differential termination.
5. 20 – 80 %.
6. Loss Of Signal is LVTTTL. Logic 0 indicates normal operation; logic 1 indicates no signal detected.

## V. Pin Description

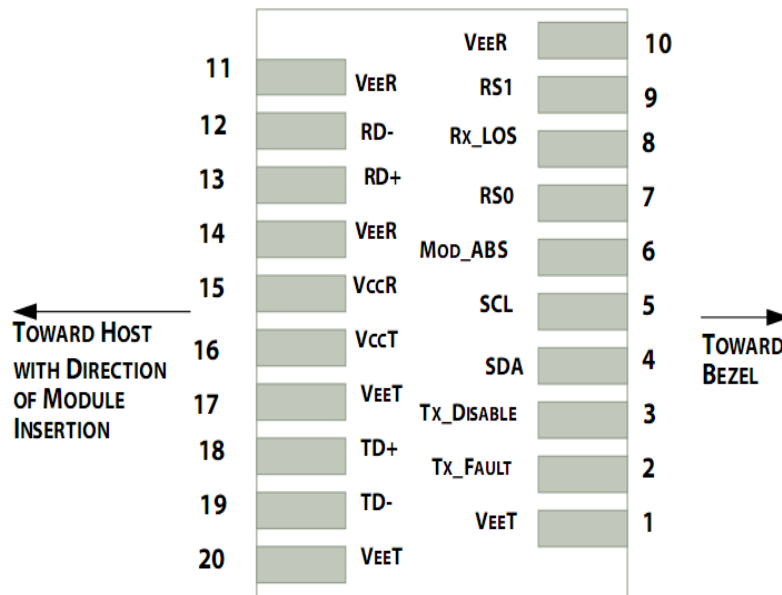

Pin out of Connector Block on Host Board

Pin	Symbol	Name/Description	NOTE
1	V <sub>EET</sub>	Transmitter Ground (Common with Receiver Ground)	1
2	T <sub>FAULT</sub>	Transmitter Fault.	2
3	T <sub>DIS</sub>	Transmitter Disable. Laser output disabled on high or open.	3
4	SDA	2-wire Serial Interface Data Line	4
5	SCL	2-wire Serial Interface Clock Line	4
6	MOD_ABS	Module Absent. Grounded within the module	4
7	RS0	no connection	
8	LOS	Loss of Signal indication. Logic 0 indicates normal operation.	5
9	RS1	Internally connect to circuit ground	
10	V <sub>EER</sub>	Receiver Ground (Common with Transmitter Ground)	1
11	V <sub>EER</sub>	Receiver Ground (Common with Transmitter Ground)	1
12	RD-	Receiver Inverted DATA out. AC Coupled	
13	RD+	Receiver Non-inverted DATA out. AC Coupled	
14	V <sub>EER</sub>	Receiver Ground (Common with Transmitter Ground)	1

15	$V_{CCR}$	Receiver Power Supply	
16	$V_{CCT}$	Transmitter Power Supply	
17	$V_{EET}$	Transmitter Ground (Common with Receiver Ground)	1
18	TD+	Transmitter Non-Inverted DATA in. AC Coupled.	
19	TD-	Transmitter Inverted DATA in. AC Coupled.	
20	$V_{EET}$	Transmitter Ground (Common with Receiver Ground)	1

**Notes:**

1. Circuit ground is internally isolated from chassis ground.
2.  $T_{FAULT}$  is an LVTTTL output. A high output indicates a transmitter fault caused by either the TX bias current or the TX output power or the laser temperature exceeding the preset alarm thresholds. A low output indicates normal operation. In the low state, the output is pulled to <0.8V.
3. Laser output disabled on  $T_{DIS} > 2.0V$  or open, enabled on  $T_{DIS} < 0.8V$ .
4. Should be pulled up with 4.7k $\Omega$ - 10k $\Omega$  on host board to a typical 3.3V voltage. MOD\_ABS pulls low to indicate module is plugged in.
5. LOS is open collector output. It should be pulled up with 4.7k $\Omega$  – 10k $\Omega$  on host board to a typical 3.3V voltage. Logic 0 indicates normal operation; logic 1 indicates loss of signal.

## VI. Digital Diagnostic Functions

XGIGA's (C)XP-CXX96-40D(A) serial transceivers support the 2-wire serial communication protocol as defined in the SFP+MSA. The standard SFP serial ID provides access to identification information that describes the transceiver's capabilities, standard interfaces, manufacturer, and other information.

Additionally, XGIGA SFP+ transceivers provide a unique enhanced digital diagnostic monitoring interface, which allows real-time access to device operating parameters such as transceiver temperature, laser bias current, transmitted optical power, received optical power and transceiver supply voltage. It also defines a sophisticated system of alarm and warning flags, which alerts end-users when particular operating parameters are outside of a factory set normal range.

The SFP MSA defines a 256-byte memory map in EEPROM that is accessible over a 2-wire serial interface at the 8 bit address 1010000X (A0h). The digital diagnostic monitoring interface makes use of the 8 bit address 1010001X (A2h), so the originally defined serial ID memory map remains unchanged.

The operating and diagnostics information is monitored and reported by a Digital Diagnostics Transceiver Controller (DDTC) inside the transceiver, which is accessed through a 2-wire serial interface. When the serial protocol is activated, the serial clock signal (SCL, Mod Def 1) is generated by the host. The positive edge clocks data into the SFP transceiver into those segments of the E2PROM that are not write-protected. The negative edge clocks data from the SFP transceiver. The serial data signal (SDA, Mod Def 2) is bi-directional for serial data transfer. The host uses SDA in conjunction with SCL to mark the start and end of serial protocol activation. The memories are organized as a series of 8-bit data words that can be addressed individually or sequentially.

## VII. Recommended Interface Circuit

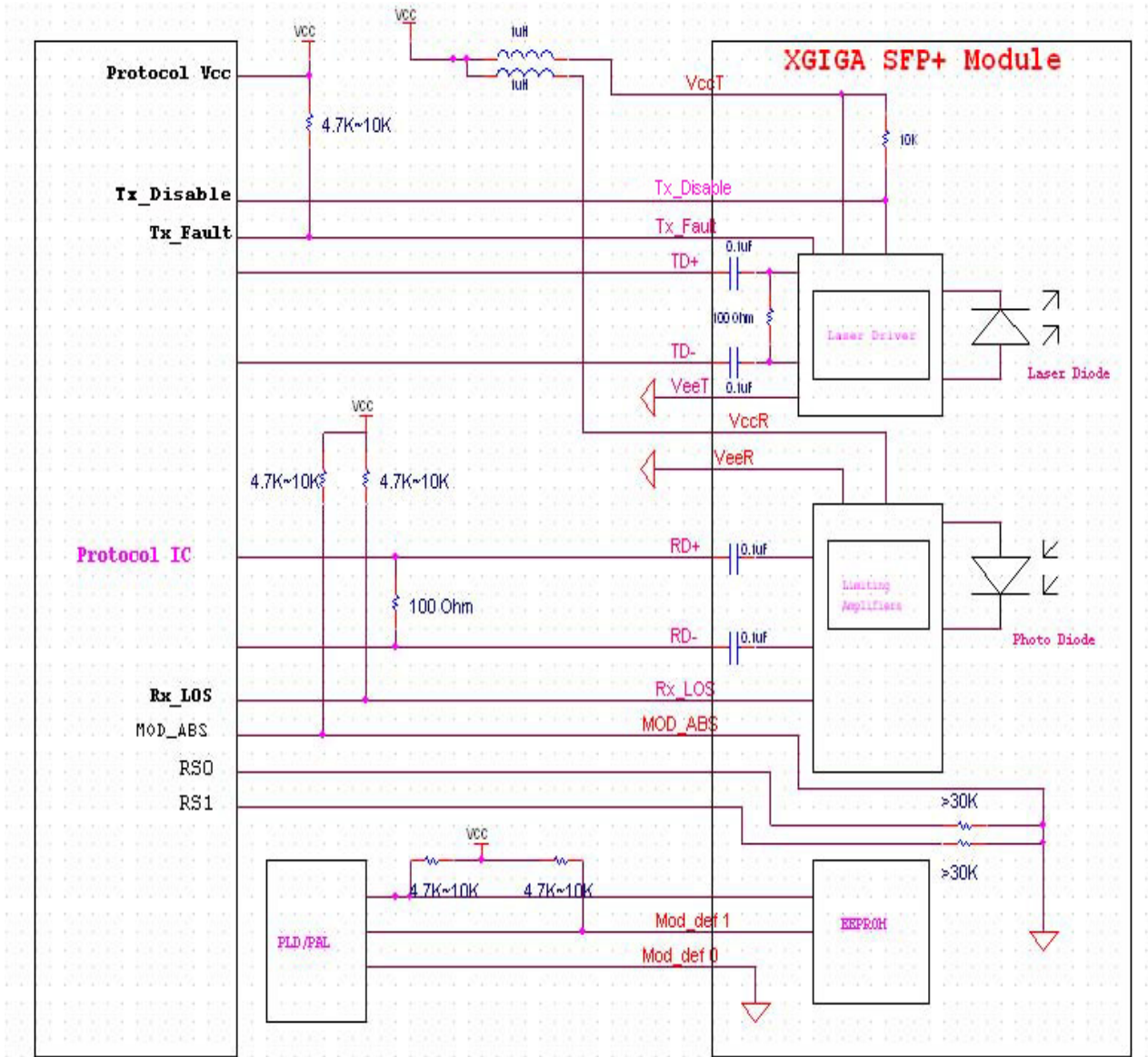

## VIII. Outline Dimensions

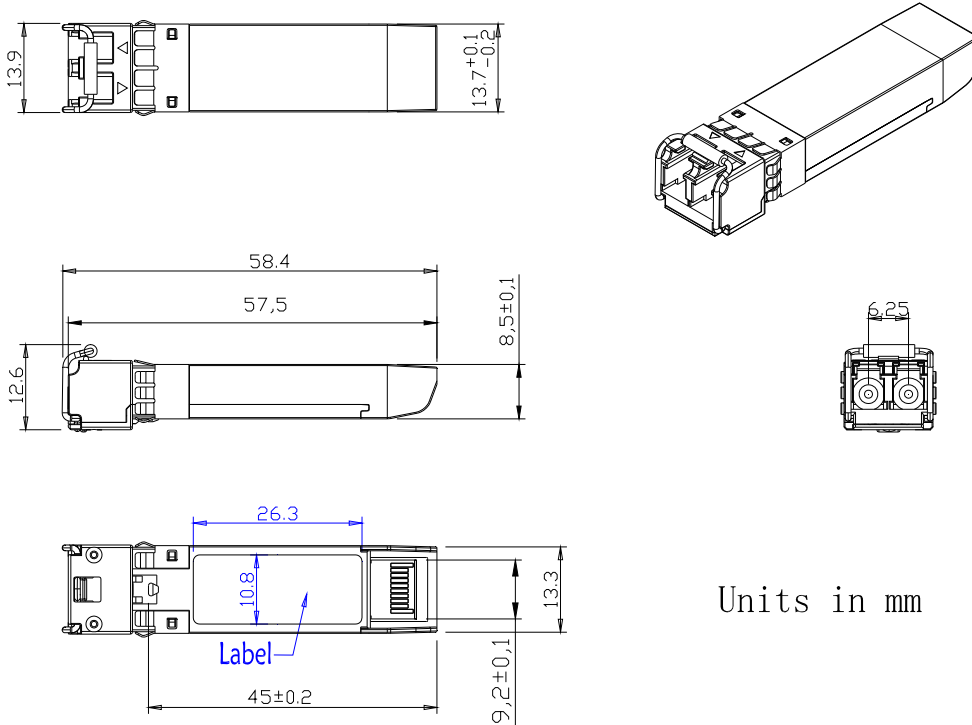

## IX. Regulatory Compliance

Feature	Reference	Performance
Electrostatic discharge (ESD)	IEC/EN 61000-4-2	Compatible with standards
Electromagnetic Interference (EMI)	FCC Part 15 Class B EN 55022 Class B (CISPR 22A)	Compatible with standards
Laser Eye Safety	FDA 21CFR 1040.10, 1040.11 IEC/EN 60825-1, 2	Class 1 laser product
Component Recognition	IEC/EN 60950, UL	Compatible with standards
ROHS	2002/95/EC	Compatible with standards
EMC	EN61000-3	Compatible with standards

### Appendix A. Document Revision

Version No.	Date	Description
1.0	2014-08-12	Preliminary datasheet
2.0	2016-01-14	Update outline dimensions