

	TYPE <b>PRODUCT SPECIFICATION</b>	NUMBER <b>GS-12-184</b>	
TITLE <b>Metral® 4000 Series – 5 Row</b>		PAGE <b>1 of 14</b>	REVISION <b>G</b>
		AUTHORIZED BY <b>S ALOSIOUS</b>	DATE <b>10 JUN 2014</b>
		STATUS <b>UNRESTRICTED</b>	

**Metral™ 4000 product family**

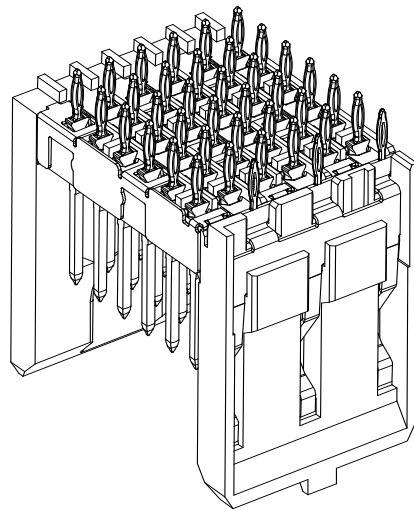
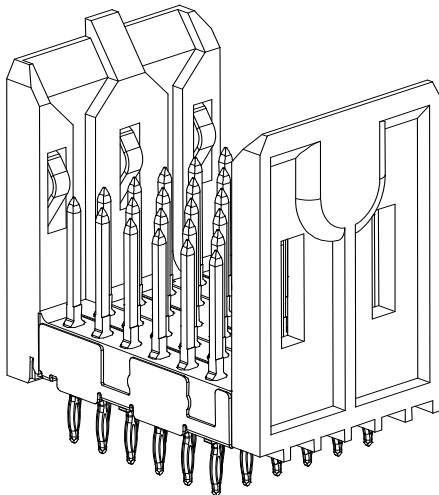
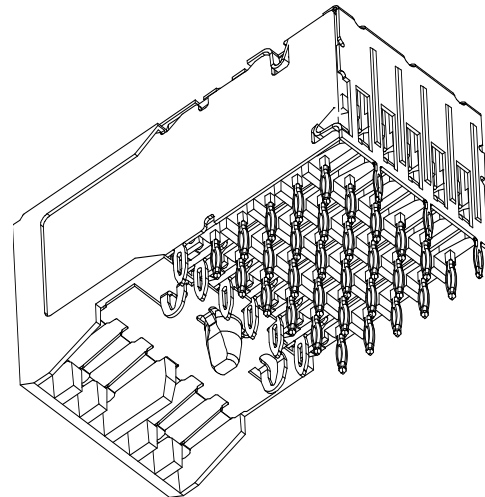
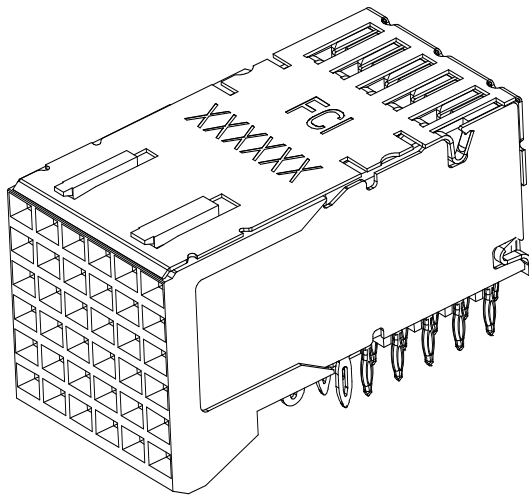

	TYPE	PRODUCT SPECIFICATION		NUMBER	GS-12-184			
	TITLE	Metral® 4000 Series – 5 Row			PAGE	2 of 14	REVISION	G
				AUTHORIZED BY	S ALOSIOUS		DATE	10 JUN 2014
				STATUS	UNRESTRICTED			

This document is composed of the following sections:

1.0	OBJECTIVE .....	3
2.0	SCOPE .....	3
3.0	GENERAL .....	3
3.1	..... Usage	3
3.2	..... Visual	3
4.0	APPLICABLE DOCUMENTS.....	4
4.1	..... Military Standards	4
4.2	..... US Federal Specifications	4
4.3	..... Other Standards and Specifications	4
4.4	..... FCI Documents	4
4.4.1	Process Specification.....	4
4.4.2	Standards and Test Specifications .....	4
4.5	..... FCI Lab Reports - Supporting Data	4
5.0	REQUIREMENTS .....	5
5.1	..... Qualification	5
5.2	..... Material	5
5.3	..... Finish	5
6.0	ELECTRICAL CHARACTERISTICS.....	6
6.1	..... Low Level Contact Resistance	6
6.2	..... Insulation Resistance	6
6.3	..... Dielectric Withstanding Voltage	6
6.4	..... Current Rating	6
6.5	..... Insertion loss	6
6.6	..... Return loss	6
6.7	..... Cross-talk	7
6.8	..... Demonstrated Backplane Link Performance	7
7.0	MECHANICAL CHARACTERISTICS .....	8
7.1	..... Mating / Unmating Force	8
7.2	..... Individual Header Pin Insertion/Retention Force	8
7.3	..... Receptacle Insertion/Retention Force	8
7.4	..... PCB Hole Deformation Radius	8
7.5	..... PCB Hole Wall Damage	8
8.0	ENVIRONMENTAL CONDITIONS .....	8
8.1	..... Thermal Shock	9
8.2	..... Humidity	9
8.3	..... High Temperature Life	9
8.4	..... Mixed Flowing Gas (4-Gas)	9
8.5	..... Vibration Sinusoidal	10
8.6	..... Mechanical Shock	10
8.7	..... Durability	10
8.8	..... Dust Contamination	10
8.9	..... Disturb	10
9.0	QUALITY ASSURANCE PROVISIONS.....	10
9.1	..... Equipment Calibration	10
9.2	..... Inspection Conditions	10
9.3	..... Sample Quantity and Description	11
9.4	..... Acceptance	11
9.5	..... Qualification Testing	11
9.6	..... Re-Qualification Testing	11
9.7	..... Qualification Test Sequence Per Table 1	11
9.9	..... Qualification Test Sequence Per Table 2	13

	TYPE	PRODUCT SPECIFICATION		NUMBER	GS-12-184
	TITLE			PAGE	REVISION
Metral® 4000 Series – 5 Row			3 of 14	G	
			AUTHORIZED BY	DATE	
			S ALOSIOUS	10 JUN 2014	
			STATUS	UNRESTRICTED	

## 1.0 OBJECTIVE

This specification defines the performance, test, quality and reliability requirements of the Metral™ 4000 family of products.

### Standard product

55003-type 5 row Metral™ 4000 Headers

59569-type 5 row Metral™ 4000 Extended Headers

52057-type 5 row Metral™ 4000 Receptacles

52062-type 5 row Metral™ 4000 Extended Receptacles

### Selectively loaded product

59566-type 5x6 Metral™ 4000 Headers

59567-type 5x6 Metral™ 4000 Extended Headers

## 2.0 SCOPE

This specification is applicable to the termination characteristics of the Metral 4000 family of products which provides a board to board matched impedance interconnect for differential pairs.

## 3.0 GENERAL

### 3.1. Usage

The headers and receptacles covered by this instruction are intended for use in a wide variety of environments.

### 3.2. Visual

Visual examinations shall be performed with a magnification up to 10x (8 to 10x recommended).

Parts should be free from blistering, cracks, discoloration, etc.

	TYPE	PRODUCT SPECIFICATION		NUMBER	GS-12-184		
	TITLE	Metral® 4000 Series – 5 Row		PAGE	4 of 14	REVISION	G
				AUTHORIZED BY	S ALOSIOUS	DATE	10 JUN 2014
				STATUS	UNRESTRICTED		

#### 4.0 APPLICABLE DOCUMENTS

##### 4.1 Military Standards

- 4.1.1 MIL-C-45662
- 4.1.2 MIL-STD-2166: Connections, Electrical, and Compliant Pin

##### 4.2 US Federal Specifications

- QQ-N-290 for nickel plating

##### 4.3 Other Standards and Specifications

- UL94-VO: Test for Flammability of Plastic Materials in Devices and Appliances
- EIA 364: Electrical Connector/Socket Test Procedures Including Environmental Classifications
- ANSI-J-002: Joint Industry Standard, Solderability Test for Component Leads, Terminations, Lugs, and Terminals and Wires
- GR-1217-CORE: Telcordia Specification "Generic Requirements for Separable Electrical Connectors"
- GR-1089-CORE: Telcordia Specification "Electromagnetic Compatibility and Electrical Safety- Generic Criteria for Network Telecommunications Equipment"
- IEC 60352-5/FDIS Solderless connection, general requirements, test methods and practical guidance
- IEC 61076-4-104 PCB connectors, detail specification for two-part modular connectors, basic grid 2 mm

##### 4.4 FCI Documents

###### 4.4.1. Process Specification

Specification	Description
BUS-15-002/X	Nickel plating
BUS-15-006/X	Tin/Lead Plating
BUS-15-005/X	Au /GXT in Contact Plating
BUS-19-020	Porosity Plating
BUS-19-040	Adhesion Plating

###### 4.4.2. Standards and Test Specifications

Specification	Description
BUS-03-404	Normal Force Measurements
BUS-15-006/X	Current Rating / 30°C Temperature Rise

##### 4.5 FCI Lab Reports - Supporting Data

Under testing

	TYPE	PRODUCT SPECIFICATION		NUMBER	GS-12-184	
	TITLE			PAGE	REVISION	
Metral® 4000 Series – 5 Row			5 of 14		G	
			AUTHORIZED BY		DATE	
			S ALOSIOUS		10 JUN 2014	
			STATUS			
			UNRESTRICTED			

## 5.0 REQUIREMENTS

### 5.1 Qualification

Connectors furnished under this specification shall be capable of meeting the qualification test requirements specified herein.

### 5.2 Material

The material for each component shall be as specified herein or equivalent.

Receptacle Contact - Copper Alloy

Receptacle Shields - Copper Alloy

Header Pins - Copper Alloy

Receptacle and Header Housings - Glass filled LCP –

Dielectric Constant – 4.0 @ 1000 Hz, 0.8 mm thick, 23°C (73°F).

Insert Molded Lead frame Assembly – Glass filled LCP –

Dielectric Constant – 3.5 @ 1000 Hz, 0.8 mm thick, 23°C (73°F).

### 5.3 Finish

Plated finishes for qualification components shall be as specified herein or equivalent. The receptacle contacts and header pins shall be qualified to the minimum thickness of either Au or GXT™ specified on product prints over a 1.3 µm minimum Ni underplate for product where Telcordia CO performance is specified on the product drawing. The Au /GXT deposit shall meet the requirements of MIL-G-45204, Type II, Grade C and the nickel deposit shall meet the requirements of QQ-N-290, Class 2. Press-fit area shall be plated with tin (lead free) over nickel if part no ends in 'LF' and tin-lead over nickel if part number does not end in 'LF'.

The Copper alloy vertical receptacle shields shall be plated with 0.5 µm minimum tin (lead free) over 1.2 µm minimum nickel if part no ends in 'LF' and 0.5 µm minimum tin-lead over 1.2 µm minimum nickel if part number does not end in 'LF'.

Copper Alloy top and bottom receptacle shields shall be plated with a 1.3 µm minimum nickel followed by the minimum Au /GXT plating thickness specified on product prints in the mating area. Press-fit area shall be plated with tin (lead free) over nickel if part no ends in 'LF' and tin-lead over nickel if part number does not end in 'LF'.

Copper Alloy header ground springs shall be plated with a 1.3 µm minimum nickel followed by the minimum Au /GXT plating thickness specified on product prints in the mating area. Press-fit areas shall be plated with tin-lead over nickel. Header stripline shields shall be plated with tin (lead free) over 1.3 µm nickel if part no ends in 'LF' and tin-lead over 1.3 µm nickel if part number does not end in 'LF'.

	TYPE	PRODUCT SPECIFICATION		NUMBER	GS-12-184		
	TITLE	Metral® 4000 Series – 5 Row		PAGE	6 of 14	REVISION	G
				AUTHORIZED BY	S ALOSIOUS	DATE	10 JUN 2014
				STATUS	UNRESTRICTED		

## 6.0 ELECTRICAL CHARACTERISTICS

### 6.1 Low Level Contact Resistance

Measurements shall be performed using a four wire method, with a maximum open circuit voltage of 20 mV, and a maximum test current of 100 mA, see EIA 364-23. The maximum initial signal contact resistance is 30 mOhm. Initial to final measurements shall not exceed 10 mOhm change. Top, middle, and bottom ground shields shall have initial maximum LLCR of 15 mOhm and also shall not exceed a 10 mOhm change.

- a. Test Voltage - 20 mV DC maximum open circuit.
- b. Test Current - Not to exceed 100 mA.

### 6.2 Insulation Resistance

The insulation resistance of mated connector pair connectors shall not be less than 1000 MOhm after environmental exposure when measured in accordance with EIA 364-21. The following details shall apply:

- a. Test Voltage - 500 V DC
- b. Electrification Time – 60 seconds
- c. Points of Measurement - Between adjacent contacts and between contacts and metal shields

### 6.3 Dielectric Withstanding Voltage

There shall be no evidence of arc-over, insulation breakdown, or excessive leakage current (> 0.5 mA) when the mated connectors are tested in accordance with EIA 364-20.

The following details shall apply:

- a. Test Voltage - 500 V DC or 500 V AC peak volts RMS or AC, 60Hz.
- b. Test Duration - 60 seconds.
- c. Voltage: Applied at a rate of 500 V per second.
- d. Points of Measurement - Between adjacent contacts and between contacts and the metal shields

### 6.4 Current Rating

The temperature rise above ambient shall not exceed 30 degree C at any point in the system when all contacts are powered at 1 A or one contact is powered at 3 A. The following details shall apply:

- a. Ambient Conditions - Still air at 25 degrees C.
- b. Reference: BUS-03-601.

### 6.5 Insertion loss

The insertion loss shall be less than 1 dB measured in a frequency range of 0 to 2.5 GHz.

### 6.6 Return loss

The return loss shall be more than 13 dB measured in a frequency range of 0 to 2.5 GHz.

	TYPE <b>PRODUCT SPECIFICATION</b>	NUMBER <b>GS-12-184</b>	
TITLE Metral® 4000 Series – 5 Row		PAGE 7 of 14	REVISION G
		AUTHORIZED BY S ALOSIUS	DATE 10 JUN 2014
		STATUS <b>UNRESTRICTED</b>	

**6.7 Cross-talk**

The cross talk shall be less than 5% measured at a 100 ps (10 - 90%) rise time.

**6.8 Demonstrated Backplane Link Performance**

(Without equalization / signal conditioning)

Up to 3.125 Gb/s over 0.5 meter using FR4 material boards

Up to 5 Gb/s over 0.5 meter using Rogers 4350 material boards

	TYPE	PRODUCT SPECIFICATION		NUMBER	GS-12-184		
	TITLE	Metral® 4000 Series – 5 Row		PAGE	8 of 14	REVISION	G
				AUTHORIZED BY	S ALOSIOUS	DATE	10 JUN 2014
				STATUS	UNRESTRICTED		

## 7.0 MECHANICAL CHARACTERISTICS

### 7.1 Mating / Unmating Force

The force to mate a receptacle connector and compatible header shall not exceed 0.55 N per contact. The unmating force shall not be less than 0.20 N per contact. The following details shall apply:

- a. Cross Head Speed – 25.4 mm / 1 inch per minute.
- b. Lubrication - None
- c. Utilize free-floating fixtures.
- d. Reference - EIA 364-13.

Total single module (5x6) mating force shall not exceed 21.5 N and total unmating force shall not be less than 6.6 N.

### 7.2 Individual Header Pin Insertion/Retention Force

The force required to insert an individual compliant pin into a plated through hole in a printed circuit board at a rate of 5 mm / 0.2 inches per minute shall not exceed 50 N. The retention force in an axial direction opposite that of insertion shall not be less than 7 N.

Total single module (5x6) insertion force shall not exceed 1950 N when inserted by a standard application press.

### 7.3 Receptacle Insertion/Retention Force

The force required to insert an individual compliant signal contact into a plated through hole in a printed circuit board at a rate of 5 mm / 0.2 inches per minute shall not exceed 50 N. The retention force in an axial direction opposite that of insertion shall not be less than 7 N.

Total single module (5x6) insertion force shall not exceed 2050 N when inserted by a standard application press.

### 7.4 PCB Hole Deformation Radius

Cross-section parallel to board surface. Photograph and measure the hole deformation (deformation of board material) radius at a point 0.25 mm (0.010 in) from the surface and at the center of the compliant pin section. The average hole deformation radius of 10 holes shall be no greater than 37.5 µm (0.0015 in) when measured from the drilled hole. The absolute maximum deformation radius shall not exceed 50 µm (0.002 in). Reference MIL-STD-2166 and IEC-60352-5/FDIS.

### 7.5 PCB Hole Wall Damage

Cross-section perpendicular to the board surface and through the compliant section wear track. Photograph and measure the copper thickness remaining between the compliant pin and the printed wiring board laminate. The minimum average copper thickness of 10 holes remaining between the compliant pin and the printed wiring board laminate shall not be less than 7.5 µm (0.0003 in). In addition, there shall be no copper cracks, separations between conductive interfaces or laminate-to-copper separations. Reference MIL-STD-2166 and IEC 60352-5/FDIS.

## 8.0 ENVIRONMENTAL CONDITIONS

After exposure to the following environmental conditions as specified in "Table 1 - Test Sequences" in accordance with the specified test procedure and/or details, the product shall show no physical damage and shall meet the electrical and mechanical requirements in sections 6 and 7.



	TYPE	PRODUCT SPECIFICATION		NUMBER	GS-12-184
	TITLE	Metral® 4000 Series – 5 Row		PAGE	9 of 14
				AUTHORIZED BY	S ALOSIUS
				REVISION	G
				DATE	10 JUN 2014
				STATUS	UNRESTRICTED

Unless specified otherwise the products shall be mated during exposure.

### 8.1 Thermal Shock

EIA 364-32, Test Condition II

Test:

1. Number of cycles: 5
2. Temperature Range: Between  $-65 +0 / -5$  degrees C and  $+105 +3 / -5$  degrees C.
3. Time at each temperature: 30 minutes
4. Transfer time: 5 minutes maximum.

### 8.2 Humidity

Mated samples are to be exposed to cyclical humidity and temperature in accordance with EIA 364-31, Method IV, with the following exceptions. Samples are to be subjected to 50 cycles of 10-hour duration for a total of 500 hours (after 24 hours in a conditioning oven at  $50 \pm 2$  °C).

A cycle consists of the following steps.

Test:

1. Ramp from  $25 \pm 2$  °C at 80% - 98% RH to  $65 \pm 2$  °C at 94 ± 4% RH in 120 minutes.
2. Dwell at  $65 \pm 2$  °C at 94 ± 4% RH for 4 hours.
3. Ramp down to  $25 \pm 2$  °C at 80% - 98% RH in 120 minutes.
4. Dwell at  $25 \pm 2$  °C at 80% - 98% RH for 2 hours.

### 8.3 High Temperature Life

EIA 364-17, Method A, Test Condition 4.

Headers and receptacles shall remain mated w/o any electrical load.

Test :

1. Temperature:  $105 \pm 2$  °C
2. Duration: 1000 hours in test group A, 300 hours in group 9 as pre-conditioning.

### 8.4 Mixed Flowing Gas (4-Gas)

Samples are to be exposed to an industrial gas mixture in accordance with Telcordia GR-1217-CORE, November 1995, Section 9.1.3. The headers ONLY are to be exposed for 10 days to the gas mixture detailed below, with interim resistance measurements made after the 5th and 10th days. The samples are then mated with the appropriate receptacle and exposed to an additional 10 days with resistance measurements taken after the 15th and 20th days of exposure. The test chamber is to be maintained at a temperature of  $30 \pm 1$  °C with a relative humidity of  $70 \pm 2$  %.

Per Central Office Requirement	
<u>Gas</u>	<u>Gas Concentration</u>
NO <sub>2</sub>	200 ppb
Cl <sub>2</sub>	10 ppb
H <sub>2</sub> S	10 ppb
SO <sub>2</sub>	100 ppb

	TYPE	PRODUCT SPECIFICATION		NUMBER	GS-12-184		
	TITLE	Metral® 4000 Series – 5 Row		PAGE	10 of 14	REVISION	G
				AUTHORIZED BY	S ALOSIUS	DATE	10 JUN 2014
				STATUS	UNRESTRICTED		

### 8.5 Vibration Sinusoidal

Perform in accordance with Telcordia GR-1217-CORE, November 1995

Test:

1. Vibration amplitude: 1.5 mm (0.06) inch DA or 10G acceleration.
2. Frequency range: 10 to 500 Hz
3. Duration: 2 hours along each of three orthogonal axes
4. Mounting: Rigidly mount assemblies
5. Requirement: No discontinuities greater than 10 nano-seconds for signal contacts, 1 micro-second for ground connections.

### 8.6 Mechanical Shock

Perform in accordance with Telcordia GR-1217-CORE, November 1995, Sections 6.3.5 and 9.1.2.1.

Test:

1. Conditions: half-sine 30G, 11 milli-second duration.
2. Shocks: 3 shocks/direction/axe.
3. Mounting: rigidly mounted assemblies.
4. Requirement: Take resistance measurements after shock in each axis.

### 8.7 Durability

Standard laboratory procedure as applicable to the specific product.

Test:

1. Number of cycles: 98 or 99 cycles per "Table 1 - Test Sequences".
2. Cycling rate: 12.5 cm (5 inches) per minute
3. Mating and unmating forces to be measured per Section 7.1. on the first and last cycle.

### 8.8 Dust Contamination

Perform in accordance with Telcordia GR-1217-CORE, November 1995, Section 9.1.1.1 & Table 9-1 unmated.

### 8.9 Disturb

An Instron compression/tensile tester shall be used to back the fully seated receptacle from the header by 0.10 mm (0.004 in). The sample is then removed and measurements made.

## 9.0 QUALITY ASSURANCE PROVISIONS

### 9.1 Equipment Calibration

All test equipment and inspection facilities used in the performance of any test shall be maintained in a calibration system in accordance with MIL-C-45662 and ISO 9000.

### 9.2 Inspection Conditions

Unless otherwise specified herein, all inspections shall be performed under the following ambient conditions:

- a. Temperature: 25 ± 5 °C
- b. Relative Humidity: 30% to 60%
- c. Barometric Pressure: Local ambient

	TYPE	PRODUCT SPECIFICATION		NUMBER	GS-12-184			
	TITLE	Metral® 4000 Series – 5 Row			PAGE	11 of 14	REVISION	G
				AUTHORIZED BY	S ALOSIUS		DATE	10 JUN 2014
				STATUS	UNRESTRICTED			

**9.3 Sample Quantity and Description**

The test sequence for the qualification testing of the receptacle and header and sample size are shown in Tables 1 and 2. The minimum connections to be tested are specified in the descriptions of each test.

**9.4 Acceptance**

Electrical and mechanical requirements placed on test samples as indicated in the sections of this specification shall be established from test data using appropriate statistical techniques or shall otherwise be customer specified, and all samples tested in accordance with the product specification shall meet the stated requirements.

Failures attributed to equipment, test set-up or operator error shall not disqualify the product. If product failure occurs, corrective action shall be taken and samples resubmitted for qualification.

**9.5 Qualification Testing**

Qualification testing shall be performed on sample units with equipment and procedures normally used in production. The test sequence for Telcordia is shown in Tables 1 and 2. The IEC test schedule for compliant sections are specified per IEC 60352-5/FDIS, see section 5.3.4 of this specification for the test schedule in flowchart format.

The IEC test schedule for the receptacle / pin interface is specified per IEC 61076-4-104, section 5: Test Schedule. An IEC standard covering signal integrity tests in under consideration.

**9.6 Re-Qualification Testing**

If any of the following conditions occur, the responsible product engineer shall initiate re-qualification testing consisting of all applicable parts of the qualification test matrices as discussed in section 9.5.

- a. A significant design change is made to the existing product, which impacts the product form, fit or function. Examples of significant changes shall include, but not be limited to, changes in the plating, material composition or thickness, contact force, pin/contact surface geometry, insulator or housing design, pin/contact base material or pin/contact lubrication.
- b. A significant change is made to the manufacturing process, which impacts the product form, fit or function.
- c. A significant event occurs during production or end use requiring corrective action to be taken relative to the product design or manufacturing process.

**9.7 Qualification Test Sequence Per Table 1**

The following connection points are to be tested for low level contact resistance in Test Groups 1 to 4 per Section 6.1 when called for in Table 1. When possible, resistance measurements should include the press-fit sections of the header and receptacle as well as the separable connection. Visual examination before any testing should confirm that the sample is not damaged or missing features. Visual examination after testing should confirm that the sample has not been damaged during testing except for the effects of the testing itself. All resistance measurements that are outside the limits should be confirmed before additional testing to assure that the measurements are correct.

TYPE OF CONNECTION	MIN. SAMPLE SIZE
Hdr. Signal Pin to Recept. Contact	100
Hdr. Ground Spring to Recept. Top Shield	96
Hdr. Ground Pin to Recept. Bottom Shield	100

	TYPE	<b>PRODUCT SPECIFICATION</b>		NUMBER		<b>GS-12-184</b>				
	TITLE			PAGE	REVISION		12 of 14		G	
Metral® 4000 Series – 5 Row			AUTHORIZED BY		DATE		S ALOSIOUS		10 JUN 2014	
			STATUS		<b>UNRESTRICTED</b>					

**Table 1 - Test Matrix**

		TEST GROUP								
		1	2	3	4	5	6	7	8	9
<b>MIN Q'TY OF 5x6 RECEPTACLES</b>		40	32	40	32	4	4	4	32	
<b>MIN QUANTITY OF 5x6 HEADERS</b>		40	32	40	32	4	4	4	32	
TEST	PARA	TEST SEQUENCE								
		MFG	Hi-Temp Life	Thermal Shock & Humidity	Vibration & Mech. Shock	Hole Deform	Elect. Perform.	Current Rating	Mating/Unmating Force	MFG with pre-condit.
EXAMINATION OF PRODUCT	3.2	1,22	1,8	1,16	1,14	1	1,5	1,3	1,3	1,27
MATE HEADER & RECEPTACLE		2,8,12	3	2,11	2,7					2,7 <sup>2</sup> ,13,17
UNMATE HEADER AND RECEPTACLE		6,10		9	5					6,11,15
<b><u>ELECTRICAL CHARACTERISTICS</u></b>										
LOW LEVEL CONTACT RESISTANCE <sup>1</sup>	6.1	3,5,9,1 3,15,17 ,19,21	4,6	3,5,13	3,8,10,13					3,5,8, 10,14,18 20,22, 24,26
INSULATION RESISTANCE <sup>1</sup>	6.2			6,14						
DIELECTRIC WITHSTANDING VOLTAGE <sup>1</sup>	6.3			7,15						
CURRENT RATING	6.4							2		
INSERTION LOSS	6.5						2			
RETURN LOSS	6.6						3			
CROSS TALK	6.7						4			
<b><u>MECHANICAL CHARACTERISTICS</u></b>										
MATING/UNMATING FORCE – 3 CYLCES	7.1								2	
HEADER INSERTION/RETENTION	7.2									
RECEPTACLE INSERTION/RETENTION	7.3									
PCB HOLE DEFORMATION RADIUS	7.4					2				
PCB HOLE WALL DAMAGE	7.5					3				
<b><u>ENVIRONMENTAL CONDITIONS</u></b>										
THERMAL SHOCK	8.1			4						
HUMIDITY	8.2			12						
HIGH TEMPERATURE LIFE 300 hrs	8.3									4
HIGH TEMPERATURE LIFE 1000 hrs	8.3		5							
MFG HEADER ONLY ( 4-GAS ) 5-DAYS	8.4	7,11								12,16
MFG MATED ( 4-GAS ) 5-DAYS	8.4	14,16								19,21
VIBRATION SINUSOIDAL – 1 EACH AXES	8.5				9					
MECHANICAL SHOCK	8.6				12					
DURABILITY 98 CYCLES	8.7	20								25
DURABILITY 99 CYCLES	8.7	4		8	4,11					9
DUST COMTAMINATION	8.8			10	6					
DISTURB	8.9	18								23

1. Insulation resistance, dielectric withstanding voltage and low level contact resistance are to be measured on different contacts.
2. Test group 9: a virgin header shall be used for the rest of the test sequence, objective of step 4 is to stress relax the receptacle.

	TYPE	<b>PRODUCT SPECIFICATION</b>		NUMBER	<b>GS-12-184</b>		
	TITLE Metral® 4000 Series – 5 Row			PAGE	13 of 14	REVISION	G
			AUTHORIZED BY	S ALOSIOUS		DATE	10 JUN 2014
			STATUS	<b>UNRESTRICTED</b>			

**9.9 Qualification Test Sequence Per Table 2**

The following connections points are to be tested for low level contact resistance in Test Groups 10 to 17 per Section 6.1 when called for in Table 2. When possible, resistance measurements should exclude the press-fit sections of the header. Visual examination before any testing should confirm that the sample is not damaged or missing features. Visual examination after testing should confirm that the sample has not been damaged during testing except for the effects of the testing itself. All resistance measurements that are outside the limits should be confirmed before additional testing to assure that the measurements are correct.

TYPE OF CONNECTION	MIN. SAMPLE SIZE
Stripline Shield to Pin	100
Stripline Shield to Ground Spring	96

The testing per Table 2 checks the internal ground connections in the Metral™ 4000 headers.

**Table 2 - Test Matrix**  
TEST GROUP

		10	11	12	13
<b>MIN QUANTITY OF 5x6 HEADERS</b>		32	32	32	32
TEST	PARA	TEST SEQUENCE			
		MFG	Hi-Temp Life	Thermal Shock & Humidity	Vibration & Mech. Shock
EXAMINATION OF PRODUCT	3.2	1,11	1,5	1,8	1,11
<b><u>ELECTRICAL CHARACTERISTICS</u></b>					
LOW LEVEL CONTACT RESISTANCE	6.1	2,4,6,8,10	2,4	2,4,7	2,4,8,10
<b><u>ENVIRONMENTAL CONDITIONS</u></b>					
THERMAL SHOCK	8.1			3	
HUMIDITY	8.2			6	
HIGH TEMPERATURE LIFE	8.3		3		
MIXED FLOWING GAS ( 4-GAS ) 5-DAYS	8.4	3,5,7,9			
VIBRATION SINUSOIDAL 1-EACH AXIS	8.5				5,6,7
MECHANICAL SHOCK	8.6				9
DUST CONTAMINATION	8.8			5	3

	TYPE	PRODUCT SPECIFICATION		NUMBER	GS-12-184	
	TITLE			PAGE	REVISION	
Metral® 4000 Series – 5 Row			14 of 14		G	
			AUTHORIZED BY		DATE	
			S ALOSIOUS		10 JUN 2014	
			STATUS			
			UNRESTRICTED			

**REVISION RECORD**

REV	PAGE	DESCRIPTION	EC #	DATE
A	ALL	NEW DOCUMENT	H20016	18 Jan 2002
B	ALL	NEW REVISION	B20111	28 May 2002
C	12,13	MODIFY SPEC.	B20203	10 Dec 2002
D	6,10	MODIFY SPEC.	B30007	15 Jan 2003
E	ALL	LOGO CHANGE	I06-0085	22 Jun 2006
F	5	GXT PLATING & LF MODIFICATION	I07-0045	27 Mar 2007
G	4 & 5	MODIFY SPEC.	ELX-I-17966	11 JUN 2014