

NUMBER <b>GS-20-0373</b>	CATEGORY <b>GENERAL APPLICATION SPECIFICATION</b>	<b>Amphenol FCI</b>	
<b>ExaMEZZ<sup>®</sup> Connector Systems, Press-Fit Products</b>		PAGE 1 of 18	REVISION K
		GUARDIAN (VERIFIED BY) David Guo	DATE 2024-06-20
		APPROVED BY Heaven Cen	
		CLASSIFICATION : <b>UNRESTRICTED</b>	

## Table of Contents

<u>Section</u>	<u>Page No.</u>
1.0 OBJECTIVE .....	2
2.0 SCOPE .....	2
3.0 GENERAL .....	2
3.1 <b>Product Description and Features</b> .....	2
3.2 <b>Product Configurations</b> .....	2
3.3 <b>Connector Guiding Features</b> .....	3
3.4 <b>PCB Spacers/Standoffs</b> .....	3
3.5 <b>Mating / Unmating Methods</b> .....	4
3.6 <b>Contact Mating and Connector Mating Sequence</b> .....	8
3.7 <b>Power Options</b> .....	9
4.0 PRINTED CIRCUIT BOARD LAYOUT INFORMATION .....	9
4.1 <b>Board Thickness</b> .....	9
4.2 <b>Multiple Connector Applications and Spacing</b> .....	9
4.3 <b>Printed Circuit Board Screen Printing Recommendations</b> .....	10
4.4 <b>Keep-Out Zones for Application and Removal Tooling</b> .....	10
4.5 <b>Row A Identification and PCB footprint labeling</b> .....	10
4.6 <b>Column Offset</b> .....	11
5.0 APPLICATION PROCEDURE .....	12
5.1 <b>Connector Insertion Tooling</b> .....	12
5.2 <b>Insertion Presses</b> .....	12
5.3 <b>Recommended Insertion Press Settings</b> .....	13
5.4 <b>Board Insertion Procedure for ExaMEZZ connectors</b> .....	13
5.5 <b>Post-Application Inspection Procedures</b> .....	14
5.6 <b>Connector Removal Tooling</b> .....	16
5.7 <b>Removal Tool Description</b> .....	16
5.8 <b>Connector Removal Procedure</b> .....	16
6.0 REFERENCE DOCUMENTS .....	17
7.0 NOTES .....	17
8.0 RECORD RETENTION .....	18

NUMBER <b>GS-20-0373</b>	CATEGORY <b>GENERAL APPLICATION SPECIFICATION</b>	<b>Amphenol FCI</b>	
TITLE <b>ExaMEZZ® Connector Systems, Press-Fit Products</b>		PAGE 2 of 18	REVISION K
		GUARDIAN (VERIFIED BY) David Guo	DATE 2024-06-20
		APPROVED BY Heaven Cen	
		CLASSIFICATION : <b>UNRESTRICTED</b>	

## 1.0 OBJECTIVE

This specification provides information and requirements regarding customer application of the ExaMEZZ connector systems with press-fit termination. This specification is intended to provide general guidance for application process development. It is recognized that no single application process will work under all customer scenarios and that customers will develop their own application processes to meet their needs. However, if these application processes differ greatly from the one recommended, FCI cannot guarantee acceptable results.

## 2.0 SCOPE

This specification provides information and requirements regarding customer application of ExaMEZZ connector systems with press-fit termination.

## 3.0 GENERAL

This document is meant to be an application guide. If there is a conflict between the product drawings and specifications, the drawings take precedence.

### 3.1 **Product Description and Features**

- The ExaMEZZ connector utilizes a hermaphroditic interface (plug and receptacle in one) for use in mezzanine applications. The same connector configuration can mate to itself.
- The product is keyed to ensure proper mating orientation.
- ExaMEZZ connectors use compliant tails to provide a reliable press-fit electrical connection between the connector and plated through hole (PTH) of the PCB. The compliant tails in ground positions are larger than in signal positions for robustness in application.
- In addition to high speed signal pairs and grounds, each column contains an extra signal pin that can be used for miscellaneous low speed signals and/or low power requirements.

### 3.2 **Product Configurations**

The ExaMEZZ Hermaphroditic connector is currently offered as shown in Table 1 below.

Stack Height per Connector Half *	Signal Pairs per Column	Number of Columns	Column Spacing	Number of Positions (Including Grounds)
7.5mm	2 Pair	15, 19	2.0mm	120, 152
12.5mm	2 Pair	15	2.0mm	120
19.5mm	2 Pair	15, 19	2.0mm	120, 152
22.5mm	2 Pair	19	2.0mm	152
19.5mm	4 Pair	11	2.0mm	154
19.5mm	4 Pair	25	2.0mm	350

**Table 1: ExaMEZZ Hermaphroditic Connector Configuration Offerings\***

UMBER <b>GS-20-0373</b>	CATEGORY <b>GENERAL APPLICATION SPECIFICATION</b>	<b>Amphenol FCI</b>	
TITLE <b>ExaMEZZ® Connector Systems, Press-Fit Products</b>		PAGE 3 of 18	REVISION K
		GUARDIAN (VERIFIED BY) David Guo	DATE 2024-06-20
		APPROVED BY Heaven Cen	
		CLASSIFICATION : <b>UNRESTRICTED</b>	

\* For example, a 7.5mm connector mated to a 19.5mm connector results in a 27.0mm stack height board to board. The mated stack height tolerance between boards is approximately  $\pm 0.25\text{mm}$ .

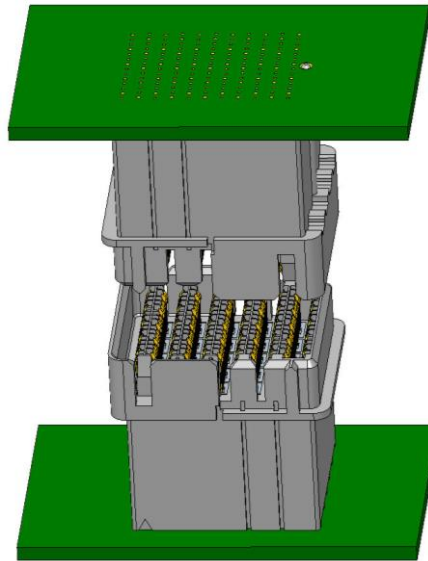

Figure 1: ExaMEZZ Hermaphroditic Connector Assembly (4 Pair, 2mm Pitch, 11 column shown)

### 3.3 Connector Guiding Features

Table 2 below shows the amount of misalignment in each direction that can be tolerated by the guiding features on the connector housings as they are mated.

Connector type	Nominal misalignment correction in direction parallel to connector columns	Nominal misalignment correction in direction perpendicular to connector columns
ExaMEZZ, standard types	$\pm 1.4 \text{ mm}$	$\pm 1.4 \text{ mm}$
ExaMEZZ, blind mate types	$\pm 3.0 \text{ mm}$	$\pm 3.0 \text{ mm}$

Table 2: Connector Guidance Features

### 3.4 PCB Spacers/Standoffs

Proper system application of ExaMEZZ Connectors requires the use of mechanical spacers/standoffs. The purpose of these spacers is to provide strain relief of connectors and connector intermate retention.

- Spacer height should be the nominal mated connector board-to-board height  $+0.10/-0.00\text{mm}$ .
- Holes on bottom PCB should be close fit to bottom screw major diameter. To assure proper mating of connectors, the top PCB holes can be up to 1.0 mm larger than spacer through shoulder diameter.

UMBER <b>GS-20-0373</b>	CATEGORY <b>GENERAL APPLICATION SPECIFICATION</b>	<b>Amphenol FCI</b>	
<b>ExaMEZZ® Connector Systems, Press-Fit Products</b>		PAGE 4 of 18	REVISION K
		GUARDIAN (VERIFIED BY) David Guo	DATE 2024-06-20
		APPROVED BY Heaven Cen	
		CLASSIFICATION : <b>UNRESTRICTED</b>	

- The through shoulder can be a cylinder with internal thread or an external thread, as shown below.
- A minimum of 4 spacers around the connector is recommended.
- Spacers are not provided with connectors. A typical spacer is shown in Figure 2 and can be purchased from hardware vendors.

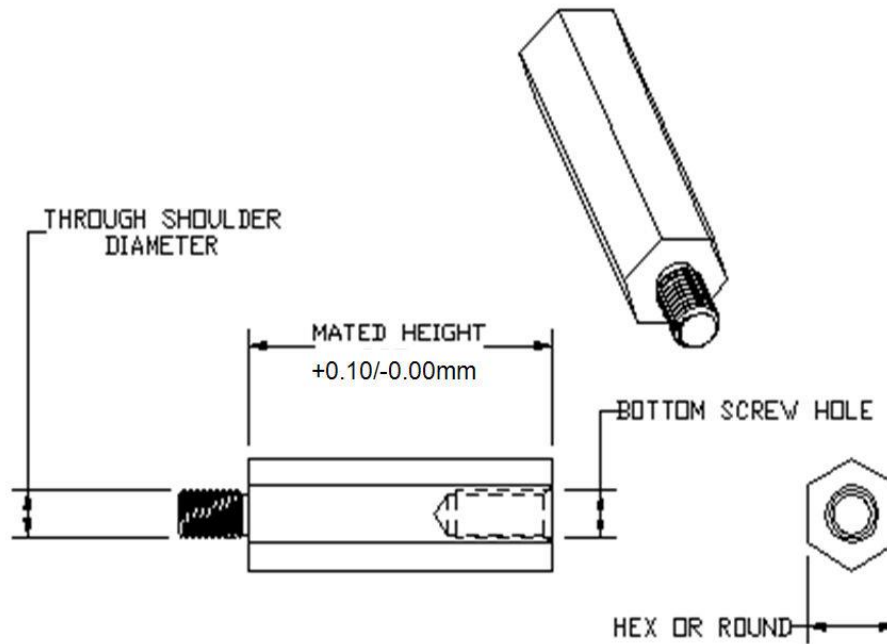

**Figure 2: PCB Spacers**

### 3.5 Mating / Unmating Methods

Whenever possible, the ExaMEZZ connector system should be mated straight on with PCBs near parallel. However, when there is a large contact count connector or multiple connectors on the board, it may be advantageous to mate the connector on a slight angle as depicted in the next few figures below to lower total mating force.

- First Pre-Mate Connectors near parallel such that keys and center datum X wall are engaged. This will allow connectors to best align themselves. Beams will start to engage at a position slightly beyond this location.

NUMBER <b>GS-20-0373</b>	CATEGORY <b>GENERAL APPLICATION SPECIFICATION</b>	<b>Amphenol FCI</b>	
<b>ExaMEZZ<sup>®</sup> Connector Systems, Press-Fit Products</b>		PAGE 5 of 18	REVISION K
		GUARDIAN (VERIFIED BY) David Guo	DATE 2024-06-20
		APPROVED BY Heaven Cen	
		CLASSIFICATION : <b>UNRESTRICTED</b>	

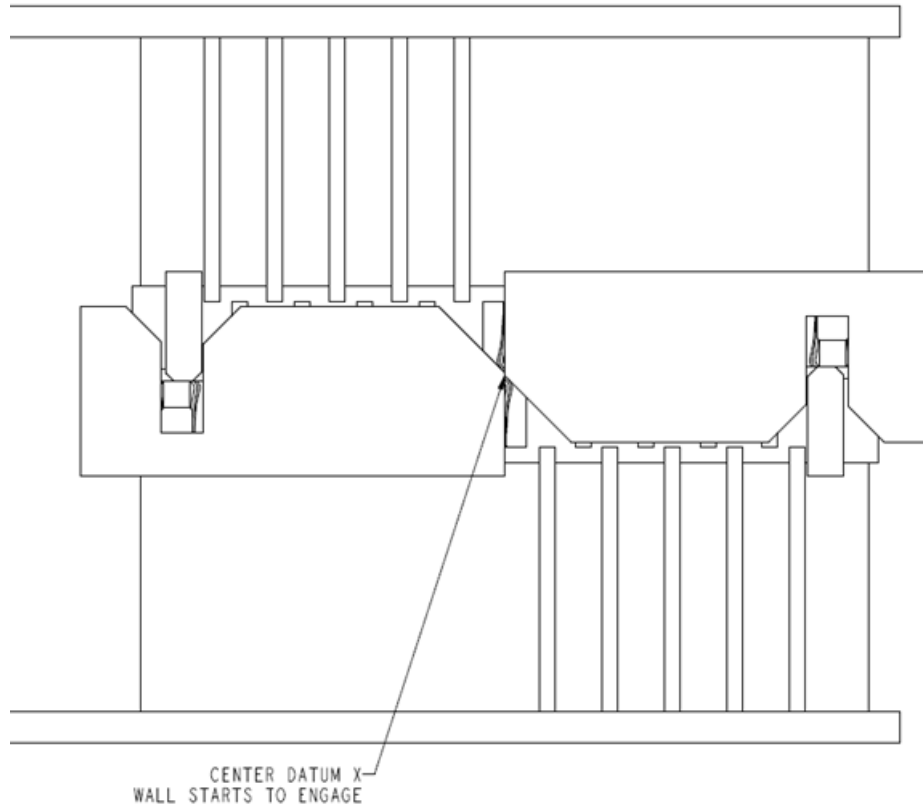

**Figure 3: Pre-mate Location**

- Slightly push down one side of the connector to a maximum of 1.5°. The example below shows the right hand side, but the left hand side could be chosen as well. Contacts will start to engage.

NUMBER <b>GS-20-0373</b>	CATEGORY <b>GENERAL APPLICATION SPECIFICATION</b>	<b>Amphenol FCI</b>	
<b>ExaMEZZ® Connector Systems, Press-Fit Products</b>		PAGE 6 of 18	REVISION K
		GUARDIAN (VERIFIED BY) David Guo	DATE 2024-06-20
		APPROVED BY Heaven Cen	
		CLASSIFICATION : <b>UNRESTRICTED</b>	

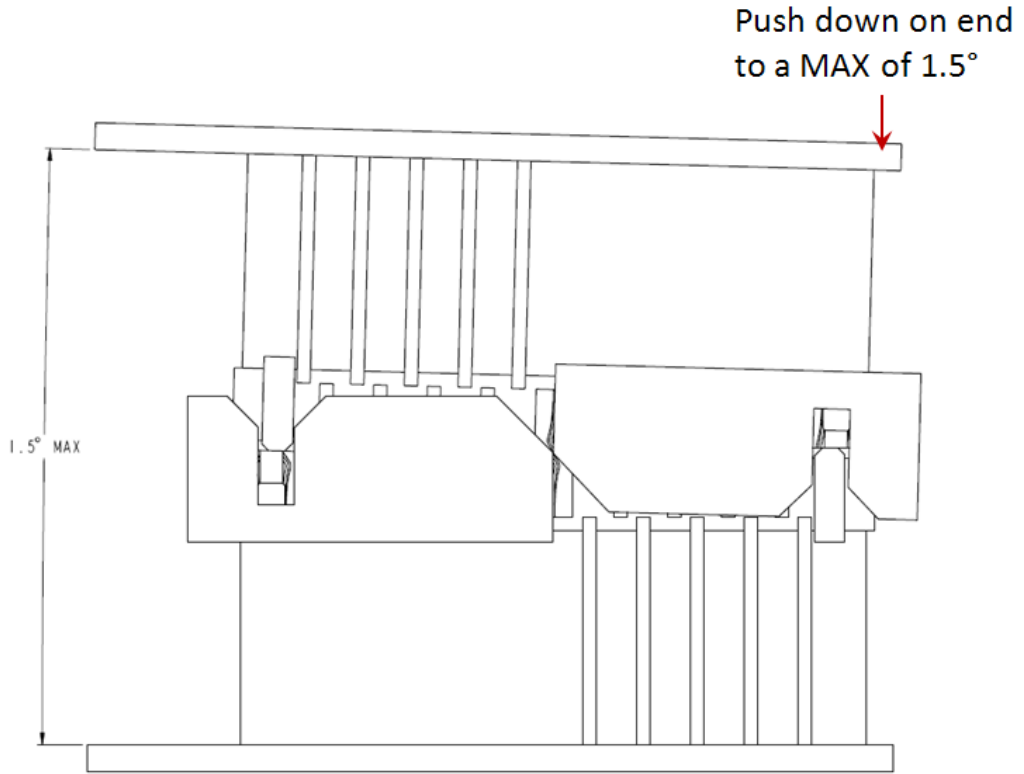

**Figure 4: Slightly Push One End to 1.5° Maximum**

- Continue Mating at 1.5° Maximum until near the bottom.

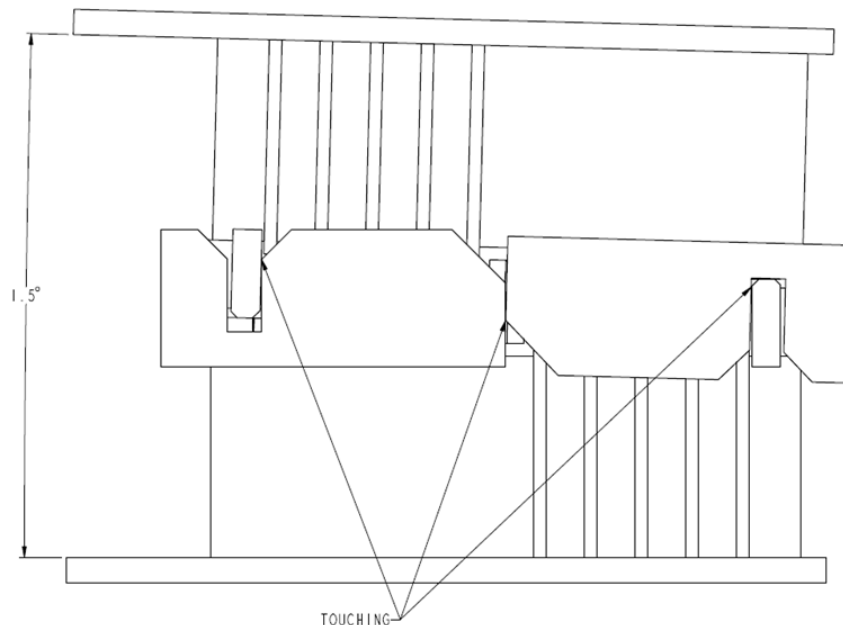

**Figure 5: Continue Mate at 1.5° Maximum until Bottoms**

NUMBER <b>GS-20-0373</b>	CATEGORY <b>GENERAL APPLICATION SPECIFICATION</b>	<b>Amphenol FCI</b>	
<b>ExaMEZZ® Connector Systems, Press-Fit Products</b>		PAGE 7 of 18	REVISION K
		GUARDIAN (VERIFIED BY) David Guo	DATE 2024-06-20
		APPROVED BY Heaven Cen	
		CLASSIFICATION : <b>UNRESTRICTED</b>	

- When bottom is reached, ensure connectors and PCB's are brought back close to parallel

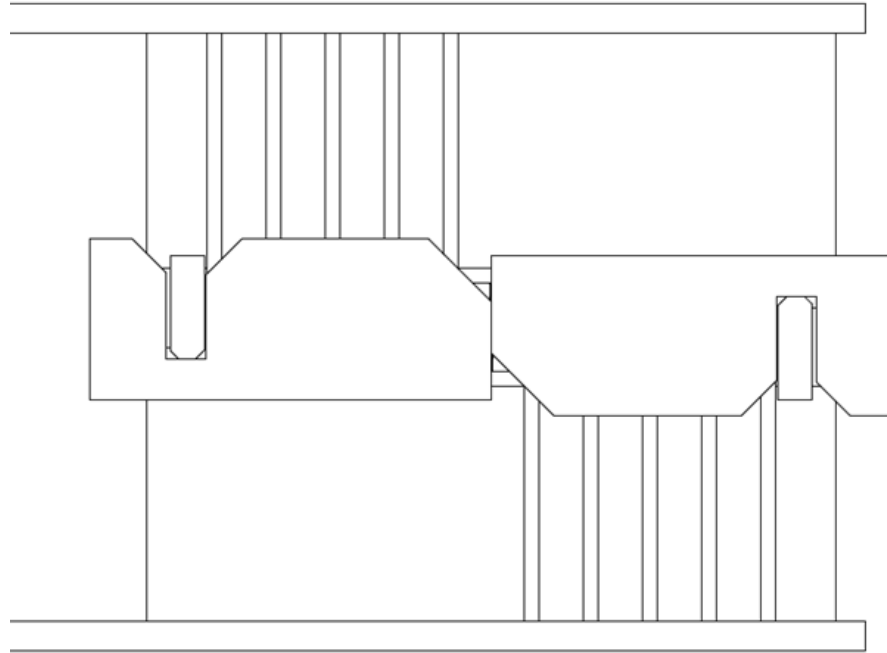

**Figure 6: Final Mate Condition - Near Parallel**

Like mating the connector, the connector it is preferable to unmate the connectors by pulling them straight apart. However, it requires less effort if the connectors are rocked side to side with a maximum of 2° while pulling the boards apart as shown in the figure below.

NUMBER <b>GS-20-0373</b>	CATEGORY <b>GENERAL APPLICATION SPECIFICATION</b>	<b>Amphenol FCI</b>	
<b>ExaMEZZ® Connector Systems, Press-Fit Products</b>		PAGE 8 of 18	REVISION K
		GUARDIAN (VERIFIED BY) David Guo	DATE 2024-06-20
		APPROVED BY Heaven Cen	
		CLASSIFICATION : <b>UNRESTRICTED</b>	

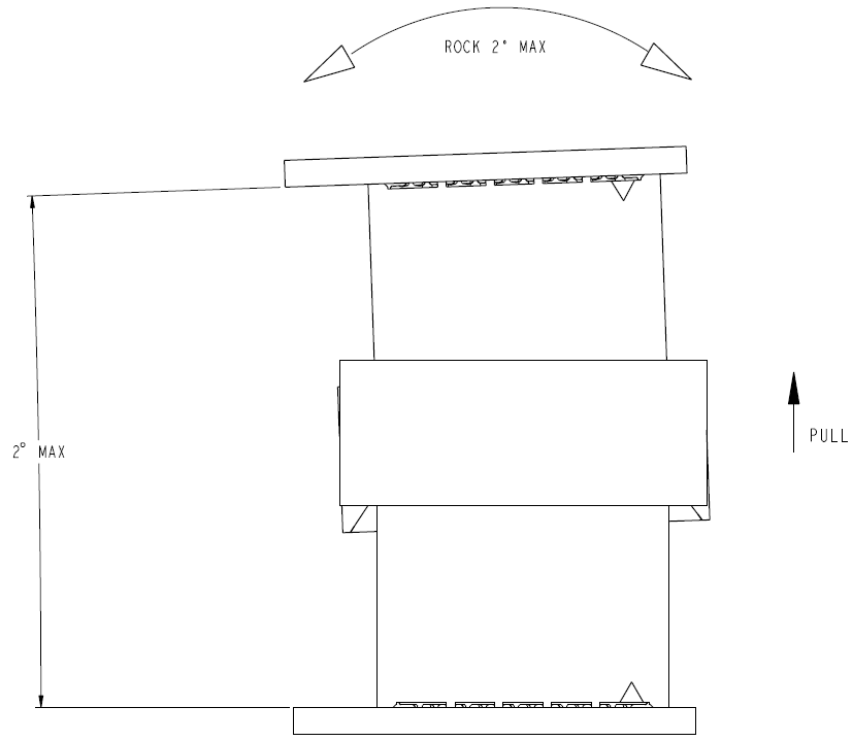

**Figure 7: Unmate Rock Side to Side**

### 3.6 Contact Mating and Connector Mating Sequence

The ExaMEZZ connector system is capable of providing three different mating wipe lengths. When specifying the short detect configuration, only one connector side can have a short detect contact. When specifying the advanced mate configuration, both mating connectors need to have advanced mate contacts. See Tables 3 and 4 as well as the customer drawings for additional details.

Item	Standard Mate Only	Advanced Mate	Short Detect
Connector Suffix	-XXXXX0ULF	Not standard (see customer drawing)	-XXXXX1ULF
Contact Location	All	2 <sup>nd</sup> and 2 <sup>nd</sup> Last Column, Top Contact	First and Last Column, Row A

**Table 3: Contact Mating Details**



NUMBER <b>GS-20-0373</b>	CATEGORY <b>GENERAL APPLICATION SPECIFICATION</b>	<b>Amphenol FCI</b>	
TITLE <b>ExaMEZZ® Connector Systems, Press-Fit Products</b>		PAGE 9 of 18	REVISION K
		GUARDIAN (VERIFIED BY) David Guo	DATE 2024-06-20
		APPROVED BY Heaven Cen	
		CLASSIFICATION : <b>UNRESTRICTED</b>	

Un-Mate Nominal Distance (mm)	Description
6.0	Housing Keys and Keyways start to align connectors
4.7	Housing Keys and Keyways are fully engaged
4.4	Advanced Mate contacts first touch
3.7	Advanced mate contacts reliable wipe begins
3.6	Standard Mate contacts first touch
2.6	Short Detect beam makes contact with Standard Mate beam
2.5	Standard Mate contacts reliable wipe begins
2.2	Short Detect contact reliable wipe begins
0.0	Connectors fully mated

**Table 4: Connector Mating Sequence**

### 3.7 Power Options

The ExaMEZZ connector system can be configured to provide both high speed signal and power within the same connector. While any contacts within the ExaMEZZ connector can be used for power, we do not recommend using short detect contacts. If ground contacts are used for power, all the ground contacts within a column must be used for power because they are commoned together. Refer to ExaMAX ExaMEZZ Power Design Guide, GS-20-0456, for additional details.

## 4.0 PRINTED CIRCUIT BOARD LAYOUT INFORMATION

**Note:** Refer to **routing guide GS-20-0511** for additional detail and recommendations on optimization of footprint and trace routing layout.

### 4.1 Board Thickness

The minimum PCB thickness that does not require PCB back-up tooling for EON tip clearance is 1.75mm. If back-up tooling will be used, the minimum PCB thickness is 1.30mm. There is no maximum thickness requirement.

### 4.2 Multiple Connector Applications and Spacing

The ExaMEZZ connectors in general are not stacked directly next to each other. Spacing will depend upon orientation to the board. Please refer to customer drawings for overall size, and allow at least 0.10mm clearance all around each mated connector pair for tolerance stack-up. This will result in a 0.20mm minimum gap between two ExaMEZZ connectors, see Figure 8 below. True position between patterns of PCB holes must be within  $\varnothing 0.10\text{mm}$  ( $\pm 0.05\text{mm}$ ), and all connectors should have the same orientation; example is shown in Figure 9 below.

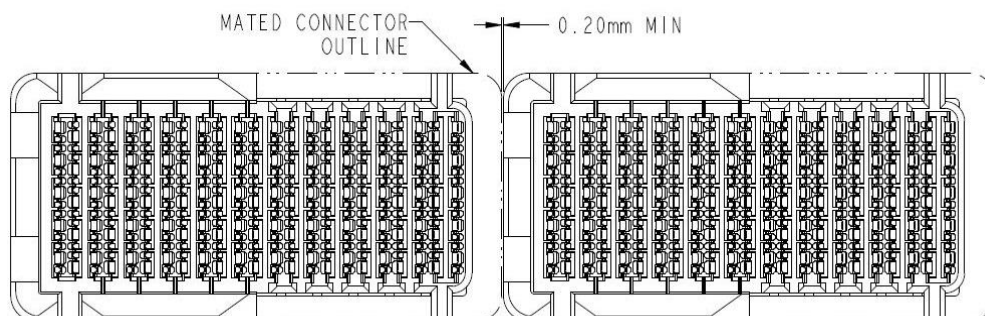

**Figure 8: Minimum Spacing**

NUMBER <b>GS-20-0373</b>	CATEGORY <b>GENERAL APPLICATION SPECIFICATION</b>	<b>Amphenol FCI</b>	
<b>ExaMEZZ® Connector Systems, Press-Fit Products</b>		PAGE 10 of 18	REVISION K
		GUARDIAN (VERIFIED BY) David Guo	DATE 2024-06-20
		APPROVED BY Heaven Cen	
		CLASSIFICATION : <b>UNRESTRICTED</b>	

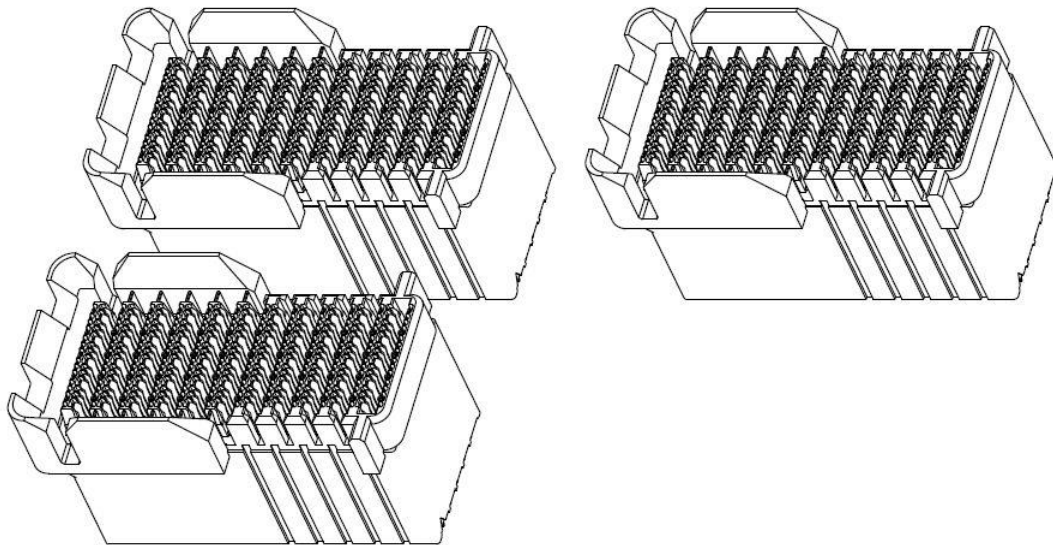

**Figure 9: Oriented in Same Direction**

#### 4.3 Printed Circuit Board Screen Printing Recommendations

It is recommended to print the outline of the connector onto the PCB to insure proper placement of the connector. Detailed information of the recommended outline is provided on the customer drawing.

#### 4.4 Keep-Out Zones for Application and Removal Tooling

There are no keep-out zones necessary for insertion application tooling because these tools fit within the outside envelope of the connector assemblies.

In order to minimize any strain on the board and other components near the connector, it is recommended that for PCB / connector rework, allowances on the connector side of the board should be made for 2mm keep-out zones adjacent to the connector on a minimum of two opposing sides. Support on all 4 sides of the connector is recommended. Refer to sections 5.7-5.8 for information on removal tools and procedures. In general, the need for keep-outs will depend on the specific PCB layout.

#### 4.5 Row A Identification and PCB footprint labeling

Because ExaMEZZ hermaphroditic connectors are self-mating, it is important to understand position identification on the connector and the PCB footprint layout.

If this hermaphroditic connector was defined with a single position A1, then the A1 positions would not line up on the mated connectors. For an 11-column connector, A1 would align with position A11, etc. To eliminate confusion, there is a Row A indicator mark at each end of the connector as shown in Figure 10. When mated, the Row A indicator marks of the first connector must line up with the row A indicator marks of the second connector.

NUMBER <b>GS-20-0373</b>	CATEGORY <b>GENERAL APPLICATION SPECIFICATION</b>	<b>Amphenol FCI</b>	
<b>ExaMEZZ® Connector Systems, Press-Fit Products</b>		PAGE 11 of 18	REVISION K
		GUARDIAN (VERIFIED BY) David Guo	DATE 2024-06-20
		APPROVED BY Heaven Cen	
		CLASSIFICATION : <b>UNRESTRICTED</b>	

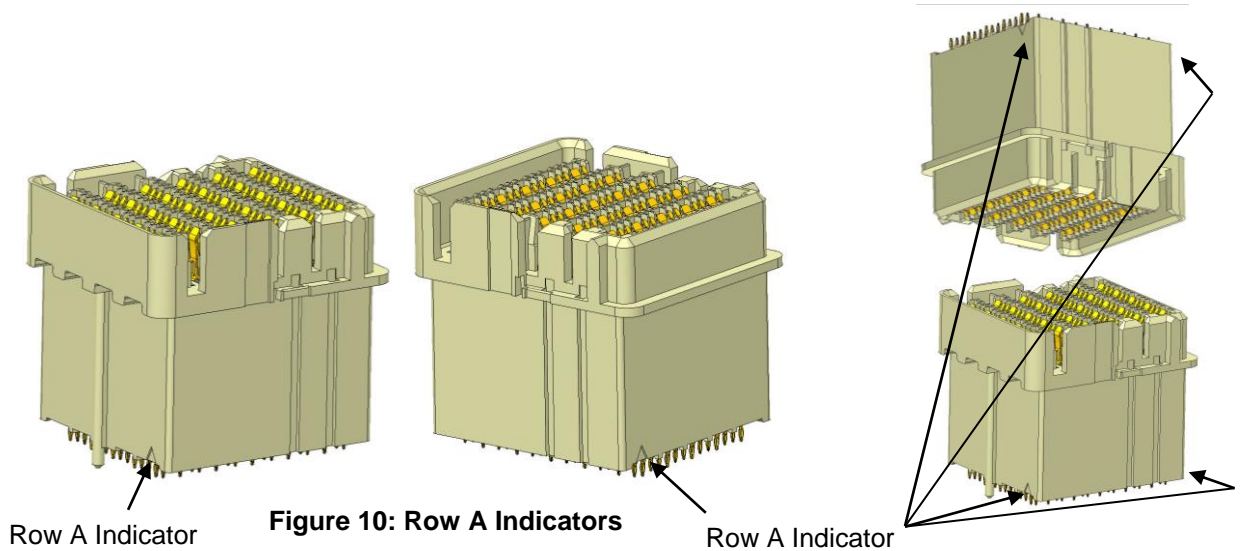

**PCB #1 (usually the main system board)** will number the columns from left to right. In order to align A1 positions of the mated boards, **PCB #2 (usually the mezzanine card)** will have the same footprint, but the column numbers will be a mirror image (right to left) of the PCB#1 layout. Please refer to Figure 11 and the applicable customer drawing.

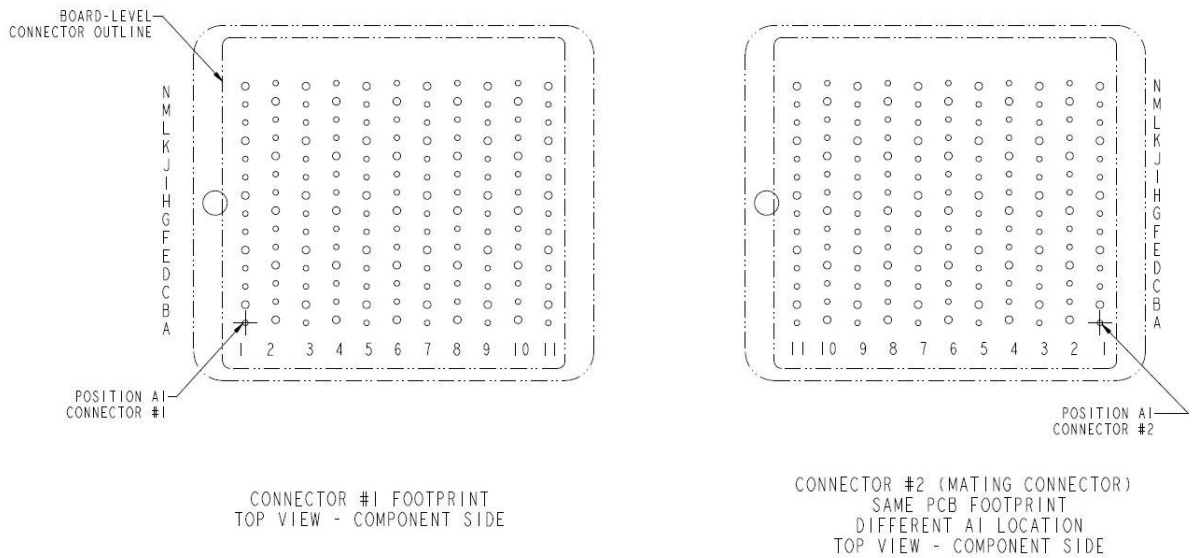
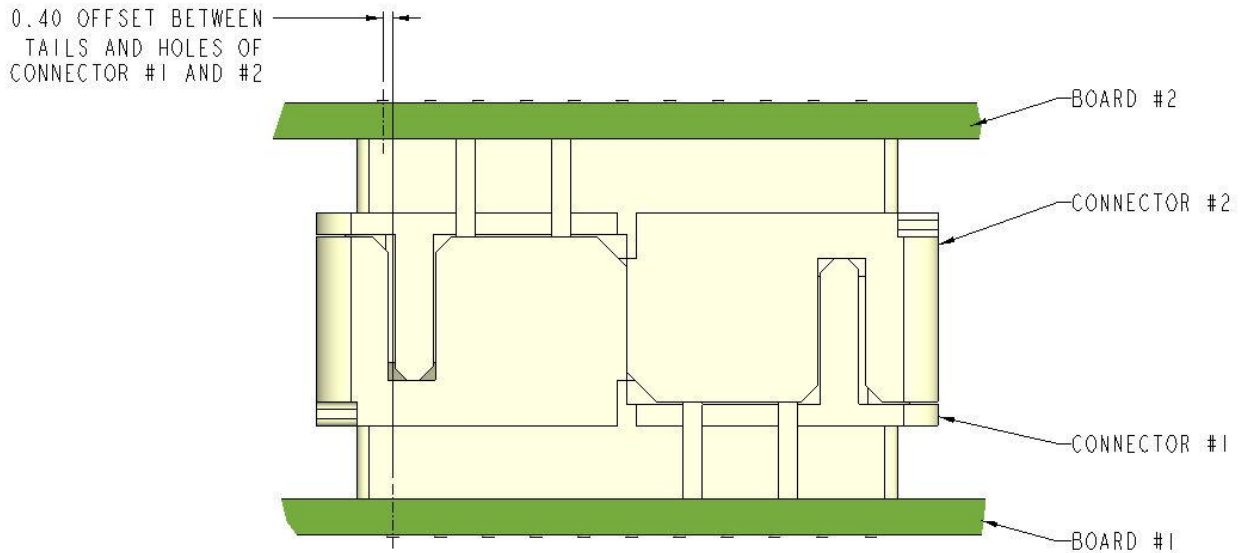

**Figure 11: PCB footprint labeling**

#### 4.6 Column Offset

When the connector on PCB #2 is flipped over to mate with the connector on PCB #1, there is a column offset of 0.4mm between the PCB footprints as shown in Figure 12.

UMBER <b>GS-20-0373</b>	CATEGORY <b>GENERAL APPLICATION SPECIFICATION</b>	<b>Amphenol FCI</b>	
<b>ExaMEZZ® Connector Systems, Press-Fit Products</b>		PAGE 12 of 18	REVISION K
		GUARDIAN (VERIFIED BY) David Guo	DATE 2024-06-20
		APPROVED BY Heaven Cen	
		CLASSIFICATION : <b>UNRESTRICTED</b>	



**Figure 12: Mated PCB hole offset**

## 5.0 APPLICATION PROCEDURE

### 5.1 Connector Insertion Tooling

The ExaMEZZ connectors are intended to be applied utilizing a “flat rock” with special insert tool listed in the table below. If the connector’s ground tails are longer than the thickness of the daughter card that the connector is being applied to (ground tail length specification is  $1.60 \pm 0.15\text{mm}$ ) a special bottom support tool will be necessary. This tool could be a PCB with oversized holes or a custom tool designed by the user.

Insertion Tool Product Number	Number of Pairs	Number of Columns	Number of Positions
10125494-015	2-Pair	15	120
10125494-019	2 Pair	19	152
10125496-011	4 Pair	11	154
10125496-025	4 Pair	25	350

**Table 5: Insertion Tool Product Numbers**

### 5.2 Insertion Presses

Several important items to consider when selecting an insertion press include:

- The press must have sufficient force capabilities.
- The press must be capable of controlling the insertion rate.
- The press must be capable of pressing per a force gradient curve.
- The press ram must be large enough to cover the insertion tooling.
- The press table must be large enough to properly accommodate the PCB size.

UMBER <b>GS-20-0373</b>	CATEGORY <b>GENERAL APPLICATION SPECIFICATION</b>	<b>Amphenol FCI</b>	
TITLE <b>ExaMEZZ® Connector Systems, Press-Fit Products</b>		PAGE 13 of 18	REVISION K
		GUARDIAN (VERIFIED BY) David Guo	DATE 2024-06-20
		APPROVED BY Heaven Cen	
CLASSIFICATION : <b>UNRESTRICTED</b>			

FCI recommends using a servo driven electronic press from the Tyco Electronics (ASG) MEP family of presses. See section 5.3 for programming details.

### 5.3 Recommended Insertion Press Settings

The recommended maximum insertion force is 12N for Copper OSP, Immersion Tin, Immersion Silver, or Tin lead plated through holes. The recommended maximum insertion force is 18N for ENIG plated through holes.

FCI recommends using a 75 degree force gradient press profile to ensure that the connectors are fully seated, while at the same time are not damaged by over pressing the connectors onto the board. A typical 75 degree press profile would look like Figure 13 below. The recommended insertion rate is 0.050"/sec for the entire time the ram is in contact with the connector press tool.

**Note: FCI RECOMMENDS THAT ONLY ONE CONNECTOR ASSEMBLY BE INSERTED AT A TIME. If more than one connector is inserted at the same time then extra care must be taken to ensure that the push surface of the tool is parallel to the component surface of the board.**

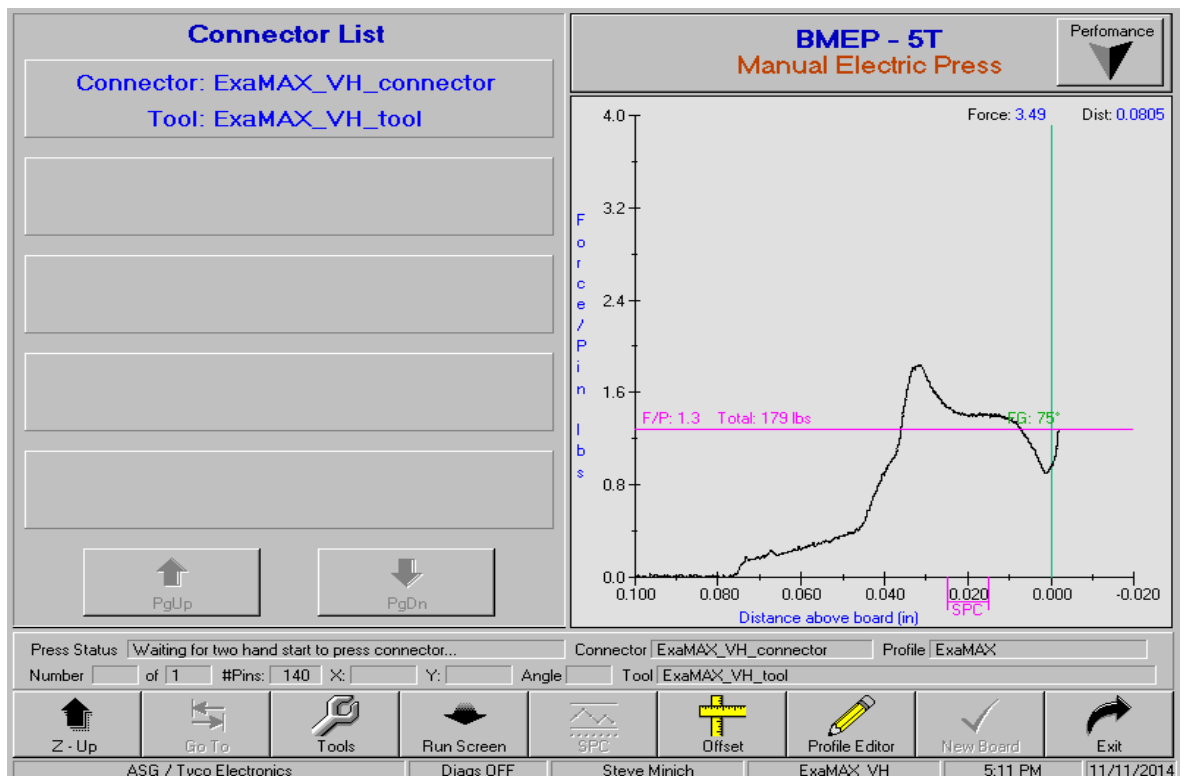
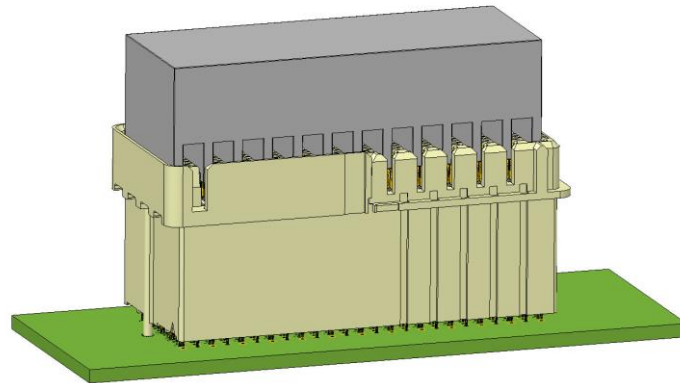

Figure 13: Example of 75 Degree Force Gradient Press Profile

### 5.4 Board Insertion Procedure for ExaMEZZ connectors

- Place insert tool into the connector assembly and set in the desired location on the printed circuit board taking care to assure that all press-fit tails line up with the proper holes and each cavity slot of the connector has a blade from the insert tool located in it.

NUMBER <b>GS-20-0373</b>	CATEGORY <b>GENERAL APPLICATION SPECIFICATION</b>	<b>Amphenol FCI</b>	
TITLE <b>ExaMEZZ® Connector Systems, Press-Fit Products</b>		PAGE 14 of 18	REVISION K
		GUARDIAN (VERIFIED BY) David Guo	DATE 2024-06-20
		APPROVED BY Heaven Cen	
		CLASSIFICATION : <b>UNRESTRICTED</b>	



**Figure 1413: Placing Insert Tool into Connector**

- Using a flat rock surface and an insertion press, apply force to the top of the insert tool as shown in the picture below.

**75 degree Force Gradient (12 N MAX per pin)**

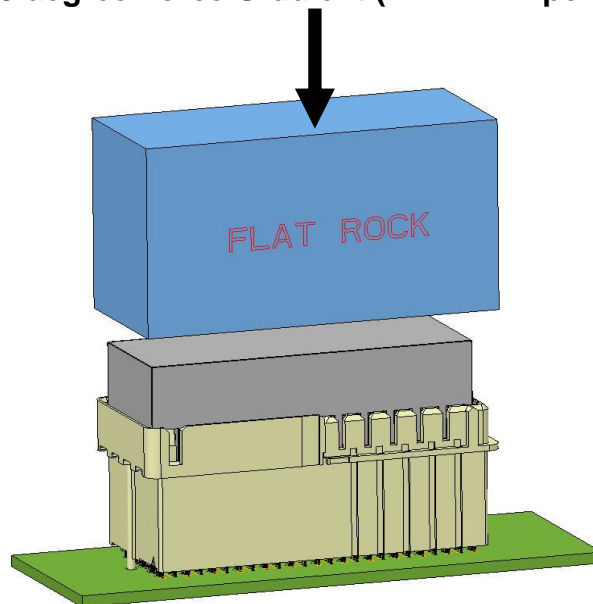

**Figure15: Pressing Connector to PCB**

- Inspect for proper application (refer to section 5.5).

### 5.5 Post-Application Inspection Procedures

The post-application inspection should consist of several simple checks to assure that the connector is applied properly and is not damaged.

- Visually assure that all press-fit tails are seated in the proper PCB holes and that none have been crushed during application.

NUMBER <b>GS-20-0373</b>	CATEGORY <b>GENERAL APPLICATION SPECIFICATION</b>	<b>Amphenol FCI</b>	
TITLE <b>ExaMEZZ<sup>®</sup> Connector Systems, Press-Fit Products</b>		PAGE 15 of 18	REVISION K
		GUARDIAN (VERIFIED BY) David Guo	DATE 2024-06-20
		APPROVED BY Heaven Cen	
		CLASSIFICATION : <b>UNRESTRICTED</b>	

- Visually check that the standoffs on the bottom of each assembly are seated within 0.10 mm of flush to the PCB (see Figure 16). A larger gap beneath the standoffs or retainer may indicate that the connector is not seated fully or is not seated parallel to the board.

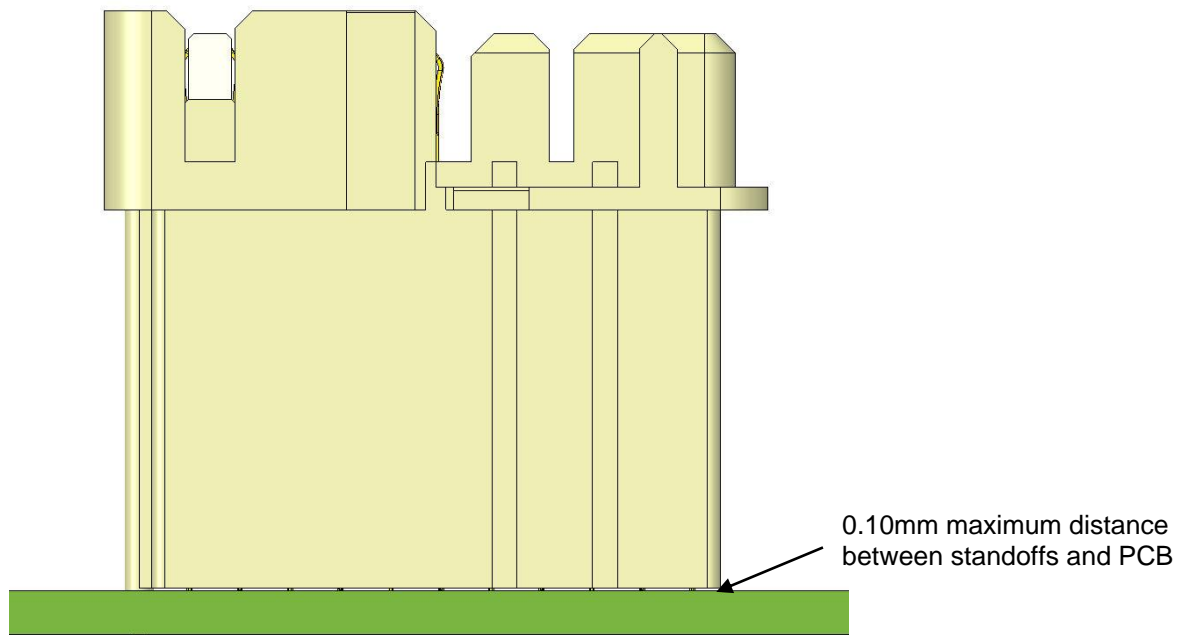

**Figure16: Proper Seating after Board Application**

NUMBER <b>GS-20-0373</b>	CATEGORY <b>GENERAL APPLICATION SPECIFICATION</b>	<b>Amphenol FCI</b>	
TITLE <b>ExaMEZZ® Connector Systems, Press-Fit Products</b>		PAGE 16 of 18	REVISION K
		GUARDIAN (VERIFIED BY) David Guo	DATE 2024-06-20
		APPROVED BY Heaven Cen	
		CLASSIFICATION : <b>UNRESTRICTED</b>	

## 5.6 Connector Removal Tooling

The following are FCI removal tool part numbers for ExaMEZZ connectors. Due to size restrictions the removal tool only presses on the ground press-fit tails.

ExaMEZZ Hermaphroditic	Column pitch, mm	Column 1 IMLA	Removal Tool part no. *
2 Pair / 15 Column	2.0	B	10125499-015
2 Pair / 19 Column	2.0	B	10125499-019
4 Pair / 11 Column	2.0	B	10125509-011
4 Pair / 25 Column	2.0	B	10125509-025

**Table 6: ExaMEZZ Removal Tools**

**\* To minimize costs the largest removal tool for a given column pitch may be used to remove any connector with that column pitch by disassembling the tool and removing pins as necessary. Extreme care must be used when doing this since the A1 location is different for ExaMAX® and ExaMEZZ® connectors. Pins only go into the ground holes.**

## 5.7 Removal Tool Description

The connector removal tool is a hand tool used to remove ExaMEZZ connectors from the back side of the circuit board by pressing on the ground EONs. A hand operated arbor press and bottom support tool (not included with removal tool) are required to actuate the tool and provide support around the connector during the removal process.

It is important to note that the ExaMEZZ Hermaphroditic connector removal tool is red in color (similar to the ExaMAX header). The ExaMAX receptacle tool is blue in color. If the wrong tool is used for rework, damage to the plated through holes and/or the tool may occur.

## 5.8 Connector Removal Procedure

- A manual arbor press is adequate to perform connector removal
- With the connector to be removed facing downward, place the board assembly over a bottom support tool (not included) that is appropriate for the board layout (see Figure 17).
- It is preferred to support on all 4 sides (2 minimum) of the connector. Also make sure that no small components (chip resistors, chip capacitors, etc.) are between the board and the support tool. The size and shape of the support tooling will vary due to the connector size, number of EONs, whether there are adjacent connectors, and any other surrounding components.
- From the back side of the board, roughly align the A1 side of the tool with the A1 via location on the PCB.
- Final align the tool so that all the pins protruding from the face of the tool are inserted into the ground vias (larger 0.50mm diameter vias) belonging to the connector that you wish to remove. If the pins and vias do not align, rotate the tool 180° and try again. The pins and vias will only align one way. **DO NOT TRY TO PUSH PINS INTO SIGNAL VIAS (smaller 0.36mm diameter vias) OR WHERE THERE ARE NO VIAS. THE PINS WILL BUCKLE AND BREAK.**



UMBER <b>GS-20-0373</b>	CATEGORY <b>GENERAL APPLICATION SPECIFICATION</b>	<b>Amphenol FCI</b>	
<b>ExaMEZZ® Connector Systems, Press-Fit Products</b>		PAGE 17 of 18	REVISION K
		GUARDIAN (VERIFIED BY) David Guo	DATE 2024-06-20
		APPROVED BY Heaven Cen	
		CLASSIFICATION : <b>UNRESTRICTED</b>	

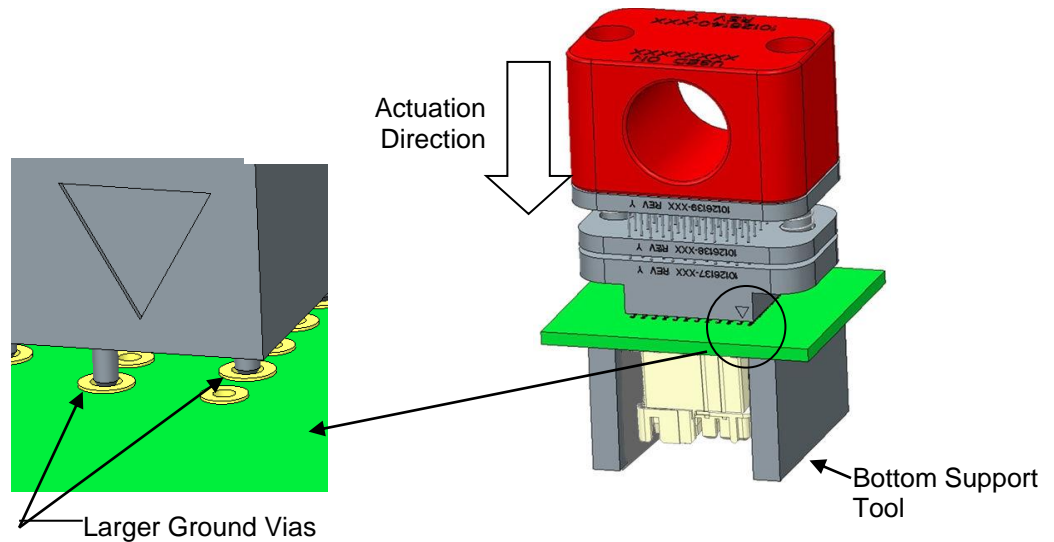

**Figure 17: Removal Tool Procedure**

- Actuate the press so that the tool is compressed. Apply pressure evenly and slowly, not with a quick motion. Stop applying pressure when the force drops or the press handle becomes easy to move. This will indicate that the EONs have released from the printed circuit board. The connector should be lying on the bench or can be easily removed by hand.

## 6.0 REFERENCE DOCUMENTS

- FCI PRODUCT SPECIFICATION GS-12-1150
- FCI PRODUCT CUSTOMER DRAWINGS
- FCI PACKAGING SPECIFICATION GS-14-920 (Lead Free Labeling)
- FCI CUSTOMER DRAWING 10119933 (Recommended Via Drill Sizes and Plating)
- ExaMAX ExaMEZZ Power Design Guide GS-20-0456
- FCI APPLICATION SPECIFICATION GS-20-0511 ExaMAX / ExaMezz Connector System Routing Guide

FCI product drawings and specifications can be obtained by accessing the FCI website [www.fci.com](http://www.fci.com) or contacting FCI Technical Service. In the event of a conflict between this application specification and the drawing, the drawing will take precedence. Customers are advised to refer to the latest revision level of FCI product drawings for appropriate details.

## 7.0 NOTES

NUMBER <b>GS-20-0373</b>	CATEGORY <b>GENERAL APPLICATION SPECIFICATION</b>	<b>Amphenol FCI</b>	
<b>ExaMEZZ® Connector Systems, Press-Fit Products</b>		PAGE 18 of 18	REVISION K
		GUARDIAN (VERIFIED BY) David Guo	DATE 2024-06-20
		APPROVED BY Heaven Cen	
		CLASSIFICATION : <b>UNRESTRICTED</b>	

## 8.0 RECORD RETENTION

REV	PAGES	DESCRIPTION	EC #	DATE
A		Released		01May14
B	2, 3, 4, 11, 14	Modify sections 3.2, 3.4, 5.1 and 5.6 to add Advanced Mate and new column configurations	ECN-ELX-V- 18777-1	01Oct14
C	4,7,8, 10,11, 12	Add Power Section 3.5. Modify sections 5.2-5.4. Max insertion F now 12 N per contact vs 15 N. New section 5.4. Remove Fig 6 Trace routing example 2 and adjust figure numbers.	ECN-ELX-V- 19552- 1	25Nov14
D	All	Chg <sup>TM</sup> to <sup>®</sup> , add section 3.4 PCB Spacers/standoffs and 3.5 Mating/Unmating Methods	ECN-ELX-V- 20050- 1	21Jan15
E	9,11	Adjust mating sequence table 4. Correct figure numbers. Adjust spacing and removal tooling clearances in 4.2 and 4.4	ECN-ELX-V- 20737- 1	22Apr15
F	11,12	Rename section 4.2, add more descriptive text and add figures for connector spacing and orientation. Move sentence "If there is a need for removal..." to 4.4. Correct figure numbers.	ECN-ELX-V- 21490- 1	23Jul15
G	1,9-10, 17-22	Insertion press "must" (vs. should) be capable. Combine 5.4 into 5.3 and reword focusing on 75° Force gradient. Add more bullets to 5.8 (was 5.9) Connector Removal. Add in Power Design Guide. Many others.	ECN-ELX-V- 22269- 1	30Oct15
H	2,9,12, 17	Update Table 4 Remove sections 4.7 – 4.12 (moved to Routing Guide) Add note referencing routing guide in section 4.0 Add reference to Routing Guide in section 6.0 Reformatted section 3.1 and removed specific reference to compliant tail sizes.	ECN-ELX-DG- 28074-1	29Sep17
J	3	Update table 2 on section 3.3 to add guiding capability information for blind mate types	ECN-ELX-DG- 31877-1	23Nov18
K	13	Add the recommended insertion force for each type of plated through hole	ECN-ELX-DG- 51899-1	24June20