

NUMBER GS-20-0469	TYPE Application Specification	Amphenol FCI	
TITLE Application Guide for Enhanced High Power Card Edge (eHPCE®) Straddle Mount Connector		PAGE 1 of 8	REVISION A
		AUTHORIZED BY Andy Lu	DATE Feb 15, 2019
		CLASSIFICATION UNRESTRICTED	

1.0 OBJECTIVE

This specification provides information and requirements regarding customer application of eHPCE® Straddle Mount Connector. This specification is intended to provide general guidance for application process development. It is recognized that no single application process will work under all customer scenarios and that customers will develop their own application processes to meet their needs. However, if these application processes differ greatly from the one recommended, Amphenol cannot guarantee results.

2.0 SCOPE

This specification provides information and requirements regarding customer application of eHPCE® Straddle Mount Connector to printed circuit boards (PCB).

3.0 GENERAL

This document is meant to be an application guide. If there is a conflict between the product drawings and specifications, the drawings take precedence.

Table 1

Enhanced High Power Card Edge	Straddle mount type, solder tail
-------------------------------	----------------------------------

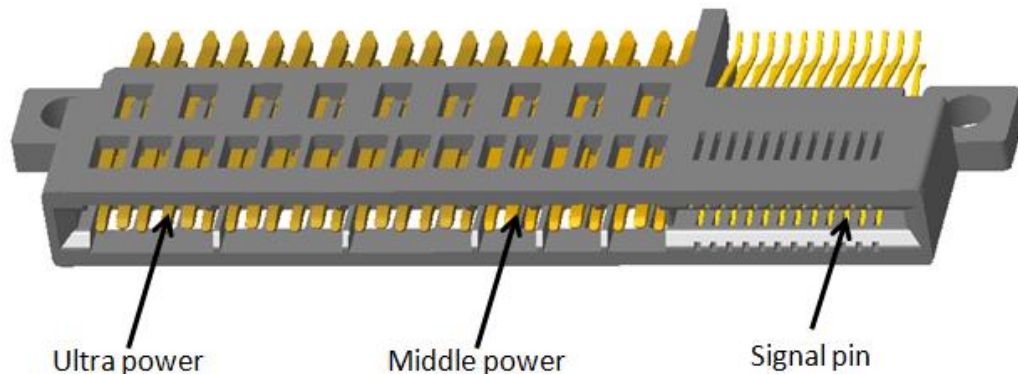

Figure 1

Configuration **Ultra power + Middle power + Signal** as shown

One Ultra power has six contact beams and four solder tails

One Middle power has three contact beams and two solder tails

4.0 DRAWINGS AND APPLICABLE DOCUMENTS

- Product Specification: GS-12-1362
- Product Drawings: 10137482, 10137755, 10141585, 10141334, etc.

Product drawings and GS-12-1362 Product Specification are available at www.amphenol-icc.com. In the event of a conflict between this application specification and the drawing, the drawing will take precedence. Customers are advised to refer to the latest revision level of product drawings for appropriate details.

NUMBER GS-20-0469	TYPE Application Specification	Amphenol FCI	
TITLE Application Guide for Enhanced High Power Card Edge (eHPCE®) Straddle Mount Connector		PAGE 2 of 8	REVISION A
		AUTHORIZED BY Andy Lu	DATE Feb 15, 2019
CLASSIFICATION UNRESTRICTED			

5.0 APPLICATION REQUIREMENTS

5.1 Product Application

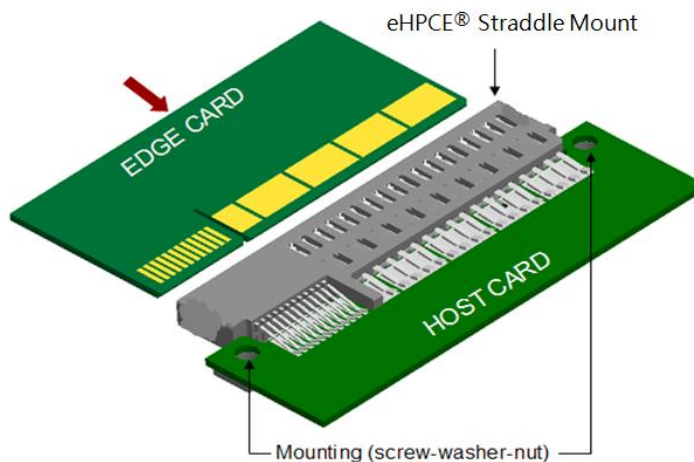

Straddle Mount Application

Figure 2

eHPCE® Straddle Mount has one options for connection to Printed Circuit Boards -- Solder to Board available as follows:

Table 2

Product Configuration	Solder Tail
eHPCE® Straddle Mount	YES

eHPCE® Straddle Mount products are compatible with standard lead-free processing, including convection, infra-red, and vapor-phase reflow, and will withstand peak processing temperatures of 260°C for a period of 60 seconds without affecting form, fit, or function.

They are versatile with many configurations to fit the individual needs of the client; the maximum length of connector is 100mm.

5.2 Wipe Distance and Contact Sequencing

Recommended minimum wipe is 3.0mm for both signal contact and power contact, the nominal wipe distance of the signal contact is shorter than the power contact by 1.05mm.

NUMBER GS-20-0469	TYPE Application Specification	Amphenol FCI	
TITLE Application Guide for Enhanced High Power Card Edge (eHPCE®) Straddle Mount Connector		PAGE 3 of 8	REVISION A
		AUTHORIZED BY Andy Lu	DATE Feb 15, 2019
CLASSIFICATION UNRESTRICTED			

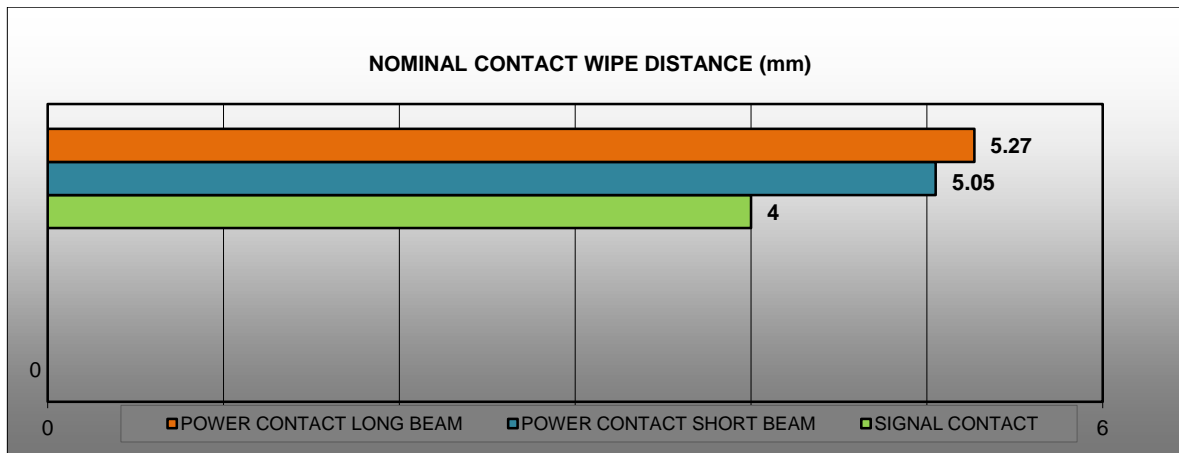

Figure 3

5.3 Mating Alignment

eHPCE® Straddle Mount connector design has not included a guide system therefore the design is not for a blind mate application. The mis-alignment allowance of the eHPCE® Straddle Mount product is depended on the condition of the connector system and the chamfer of the edge card. Please see figure 4 and table 3 for explanation.

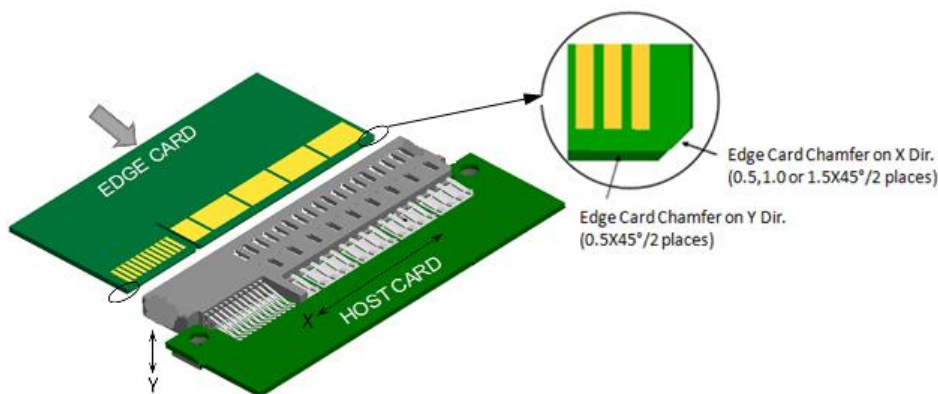

Figure 4

Connector Mating Condition	Edge Card Chamfer (mm)		Mis-Alignment Allowance (mm)		Insertion Angle Allowance (°)	
	X	Y	X	Y	X	Y
One Side is in Stationary condition, other side is in floating condition.	0.50	0.50	1.85 ± 0.125	1.60 ± 0.13	3	3
	1.00		2.35 ± 0.125			
	1.50		2.85 ± 0.125			
Both Side are in Stationary Condition			0.15 ± 0.056	0.115 ± 0.07		

Table 3

NUMBER GS-20-0469	TYPE Application Specification	Amphenol FCI	
TITLE Application Guide for Enhanced High Power Card Edge (eHPCE®) Straddle Mount Connector		PAGE 4 of 8	REVISION A
		AUTHORIZED BY Andy Lu	DATE Feb 15, 2019
		CLASSIFICATION UNRESTRICTED	

5.4 Voltage Rating

The Maximum Working Voltage of the eHPCE® Straddle Mount connector system is rated base on UL# E66906 Vol. 1 Sec. 124.

The Operating Voltage Rating: please refer to product specification GS-12-1362 section 3.1.

5.5 Current Rating

(Refer to Product Specification GS-12-1362 for additional information)

Following are the current rating values of the eHPCE® Straddle Mount connector system.

Contact current rating	
Contact type	Current (Amperes)
AMPS per UP(4P)	48A
AMPS per MP(2P)	24A
AMPS per Signal	1.0A (2.5A/pin if it is applied for standby power)

NOTES:

- The applicable maximum configuration: 56P+24S,
"56P" stands for total 56pcs solder tails of Power, "24S" stands for total 24pcs Signal pins.
- "UP" stands for Ultra Power with 4 tails, "MP" stands for Middle Power with 2 tails.
- Temperature rise: 30 °C Max.
- Test board has 8 layers and 2oz copper for each layer; top layer and bottom layer are for both signal and power, all 8 layers including (top and bottom layers) for current carrying of power.
- The maximum quantity of signal pin used for standby power is 4 pieces among total 24 pcs signal pins when signal pins are used as standby power pin with 2.5 Amp Max.

Table 4

5.6 Safety

Prevention of operator access to energized parts

Reference UL60950 & IEC 60950-1 Section 2.1.1.1

UL and IEC specifications define three different probe designs to test for prevention of operator access to energized conductors (such as powered electrical contacts within an unmated connector). The two probes are referred to as follows:

- **Test Finger** (Figure 5)
- **Test Probe** (Figure 5)

The following sections show each of these test probes positioned as closely as possible to the mating side contacts of the eHPCE® Straddle Mount, which will be located on the PCB and may be powered in an unmated state.

Although the eHPCE® Straddle Mount connector system meets these probe requirements as noted, it is not recommended that the customer "hot plug" the edge card to the Straddle Mount receptacle.

NUMBER GS-20-0469	TYPE Application Specification	Amphenol FCI	
TITLE Application Guide for Enhanced High Power Card Edge (eHPCE®) Straddle Mount Connector		PAGE 5 of 8	REVISION A
		AUTHORIZED BY Andy Lu	DATE Feb 15, 2019
		CLASSIFICATION UNRESTRICTED	

5.6.1 Test Finger

The test finger may not make contact with energized parts while the access doors and covers of the system enclosure are open. Separable connectors must be disconnected for this test. The figures show the tip of the test finger inserted into an eHPCE® Straddle Mount capture window, showing that it is impossible for the probe (shown at the smallest size per specified tolerances) to touch the receptacle contacts.

5.6.2 Test Probe

The requirements for the test probe conditions are not as clearly specified by UL and IEC. However assuming the worst-case scenario where the eHPCE® connector is accessible, the following 3D model was created. This model shows that the test probe is very large compared to the test finger and will never come close to touching a powered contact within the representative receptacle.

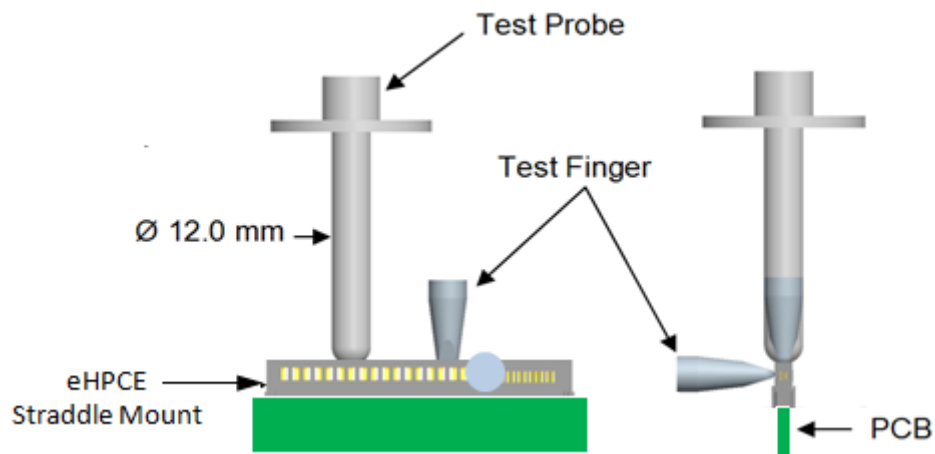

Figure 5

NUMBER GS-20-0469	TYPE Application Specification	Amphenol FCI	
TITLE Application Guide for Enhanced High Power Card Edge (eHPCE®) Straddle Mount Connector		PAGE 6 of 8	REVISION A
		AUTHORIZED BY Andy Lu	DATE Feb 15, 2019
		CLASSIFICATION UNRESTRICTED	

5.7 Requirement for Customers PCB

For specifics of the PCB layout, refer to the customer drawing of the part number being applied.

5.7.1 PCB Layout (See customer drawing for more details)

eHPCE® Straddle Mount

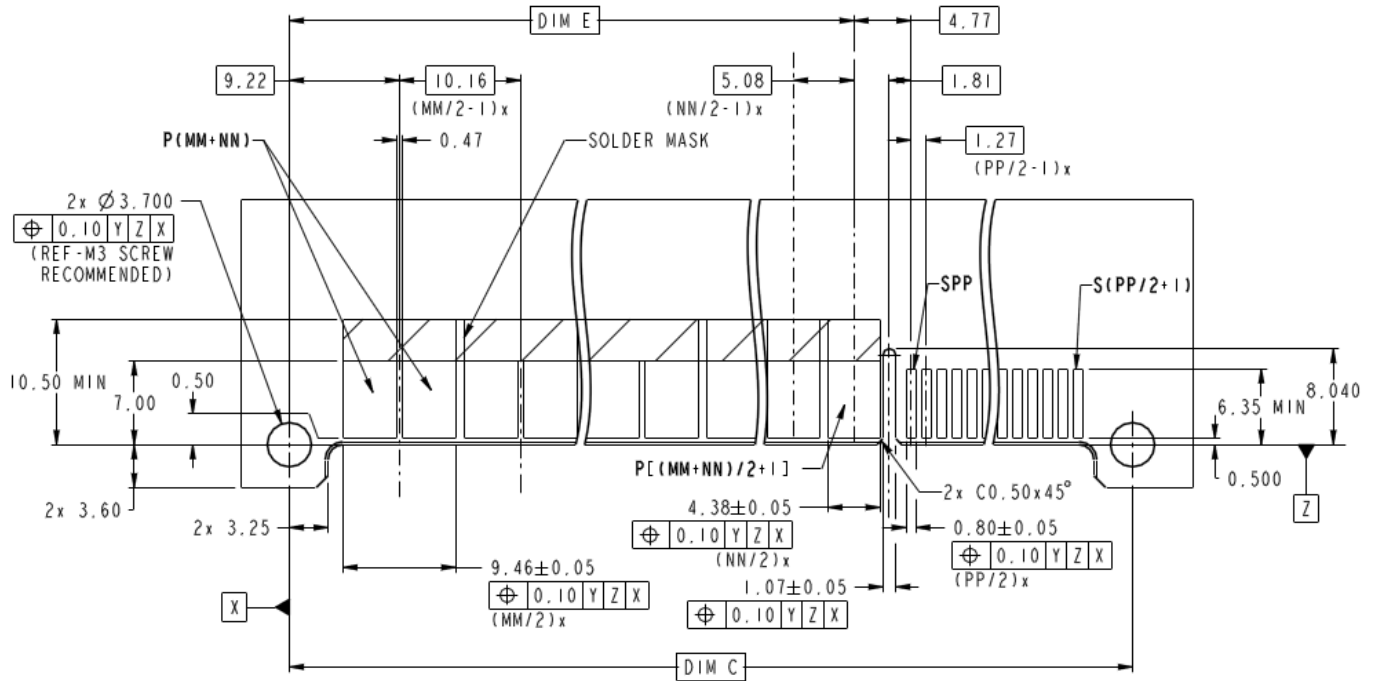

RECOMMENDED HOST BOARD LAYOUT TOLERANCE ± 0.05

Figure 6

Refer to customer drawing for DIM C & DIM E

Power and signal traces inside the connector zone need to be coated or under solder mask to protect against oxidation and minimize wear or damage during assembly and handling.

NUMBER GS-20-0469	TYPE Application Specification	Amphenol FCI	
TITLE Application Guide for Enhanced High Power Card Edge (eHPCE®) Straddle Mount Connector		PAGE 7 of 8	REVISION A
		AUTHORIZED BY Andy Lu	DATE Feb 15, 2019
		CLASSIFICATION UNRESTRICTED	

5.7.2 Edge Card Layout (See customer drawing for more details)

RECOMMENDED EDGE CARD FOOT PRINT

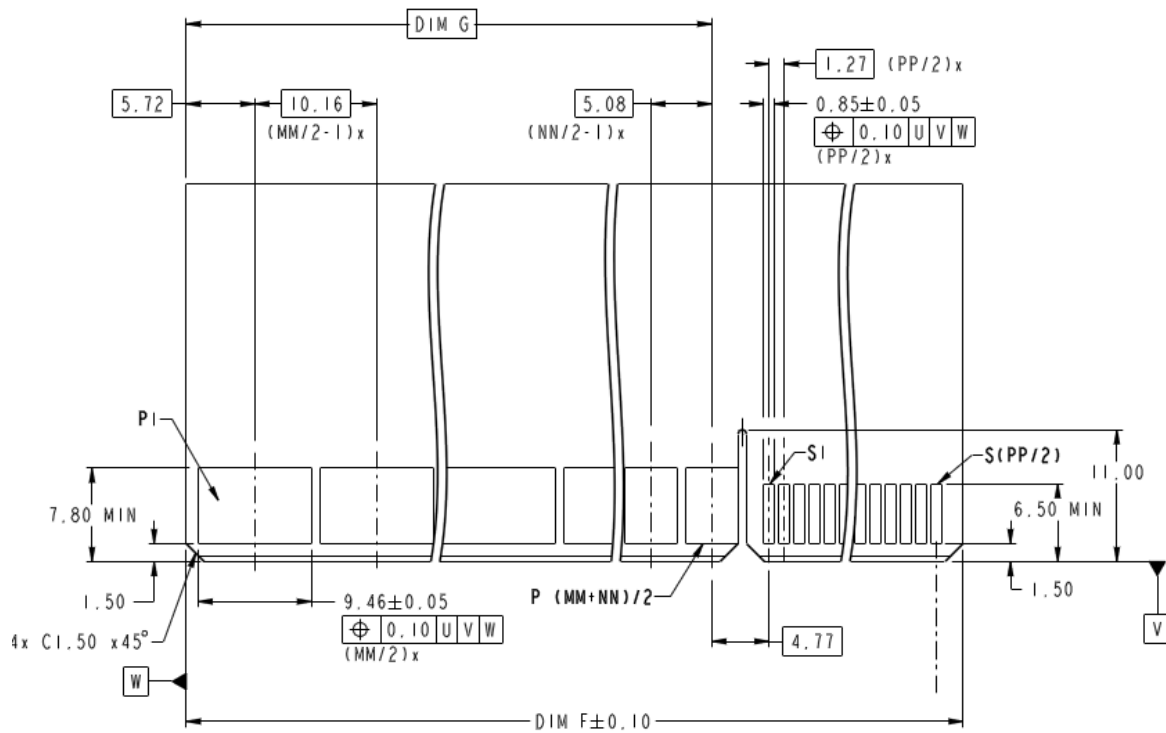

RECOMMENDED MATING BOARD LAYOUT TOLERANCE ±0.05

Figure 6

Refer to customer drawing for DIM F & DIM G

6.0 APPLICATION PROCEDURE

No application tooling is required for eHPCE Straddle Mount connector.

NUMBER GS-20-0469	TYPE Application Specification	Amphenol FCI	
TITLE Application Guide for Enhanced High Power Card Edge (eHPCE®) Straddle Mount Connector		PAGE 8 of 8	REVISION A
		AUTHORIZED BY Andy Lu	DATE Feb 15, 2019
		CLASSIFICATION UNRESTRICTED	

7.0 RECORD RETENTION

<u>REV</u>	<u>PAGE</u>	<u>DESCRIPTION</u>	<u>EC#</u>	<u>DATE</u>
A	All	Initial release	N/A	2019/Feb/15