

NUMBER GS-20-0594	TYPE Application Specification		
TITLE WireLock® Series Connector		PAGE 1 of 11	REVISION F
		AUTHORIZED BY Daisy Wu	DATE 07/06/2024
CLASSIFICATION UNRESTRICTED			

1.0 OBJECTIVE

This specification provides information and requirements regarding customer application of WireLock® Series Connector. This specification is intended to provide general guidance for application process development. It is recognized that no single application process will work under all customer scenarios and that customers will develop their own application processes to meet their needs. However, if these application processes differ greatly from the one recommended, AFCI cannot guarantee results.

2.0 SCOPE

This specification provides information and requirements regarding customer application of WireLock® Series Connector

3.0 GENERAL

This document is meant to be an application guide. If there is a conflict between the product drawings and specifications, the drawings take precedence.

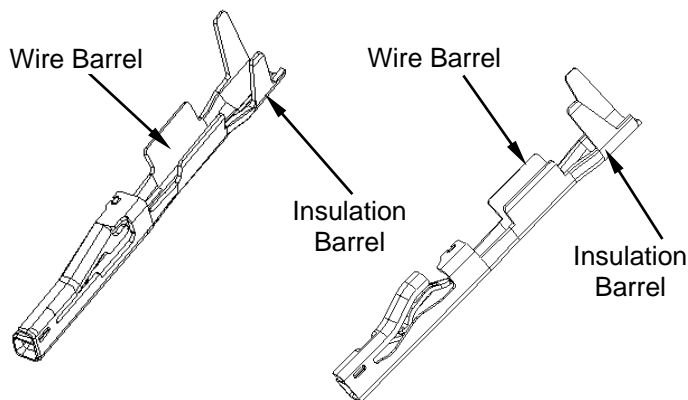

Receptacle Terminal 10153126 & 10163003 series

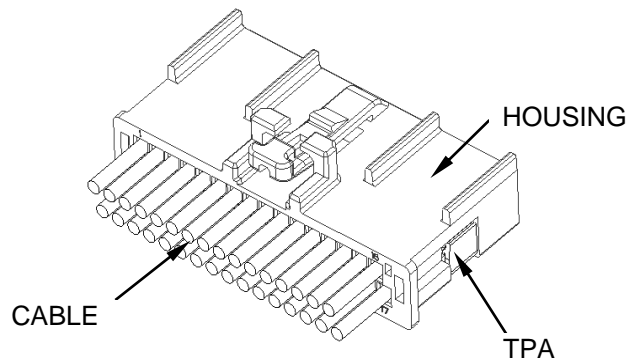

Receptacle Assembly

4.0 DRAWINGS AND APPLICABLE DOCUMENTS

- AFCI PRODUCT SPECIFICATION GS-12-1535
- AFCI PRODUCT DRAWINGS
- APPLICATION MANUALS/INSTRUCTION SHEETS (IF NOT INCLUDED IN THIS DOCUMENT)

Product drawings and **AFCI's GS-12-1535** Product Specification are available at www.amphenol-icc.com In the event of a conflict between this application specification and the drawing, the drawing will take precedence. Customers are advised to refer to the latest revision level of AFCI product drawings for appropriate details.

NUMBER GS-20-0594	TYPE Application Specification		
TITLE WireLock® Series Connector		PAGE 2 of 11	REVISION F
		AUTHORIZED BY Daisy Wu	DATE 07/06/2024
CLASSIFICATION UNRESTRICTED			

5.0 APPLICATION REQUIREMENTS

The wires in Table (1) are qualified for using with Receptacle Terminal 10153126 / 10163003 series.

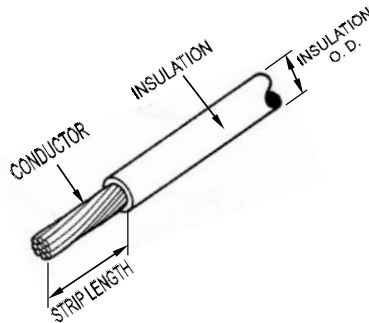

Table (1)

Wire gauge	#of Conductors	AWG	Solid -or- Stranded	Insulation Material	Insulation Diameter
UL 1061	17/0.16mm	AWG22	Stranded	SR PVC	1.30±0.1mm
UL 1061	11/0.16mm	AWG24	Stranded	SR PVC	1.15±0.1mm
-	7/0.185 mm	AWG26	Stranded	SR PVC	0.95±0.05mm
-	-	AWG28	-	-	-

6.0 APPLICATION TOOLING

Application Tooling needed for installation of Receptacle Terminal 10153126 / 10163003 is defined in Table (2):

Table (2)

Tool PN	Tool Description	Receptacle Terminal PN	Receptacle Terminal Description
JL-A20057	Semi auto crimping machine	10153126-XY2LF 10163003-002LF	Terminal for AWG22
-	Set for crimping hand tool		
JL-A20057	Semi auto crimping machine	10153126-XY2LF	Terminal for AWG24
-	Set for crimping hand tool		
JL-A20057	Semi auto crimping machine	10153126-XY1LF	Terminal for AWG26
-	Set for crimping hand tool		
-	Semi auto crimping machine	10153126-XY1LF	Terminal for AWG28
-	Set for crimping hand tool		
-	Crimping hand tool	10153126-XYXLF	Terminal for range AWG22 to AWG28

NUMBER GS-20-0594	TYPE Application Specification		
TITLE WireLock® Series Connector		PAGE 3 of 11	REVISION F
		AUTHORIZED BY Daisy Wu	DATE 07/06/2024
CLASSIFICATION UNRESTRICTED			

7.0 APPLICATION PROCEDURE

- 7.1 Strip the wire (Table 1)
- 7.2 Crimp the wire (Table 2, 3, 4)
- 7.3 Insert the wire into the receptacle housing when the TPA is at level-1 locking status.
- 7.4 Close the TPA to make it at level-2 locking status.

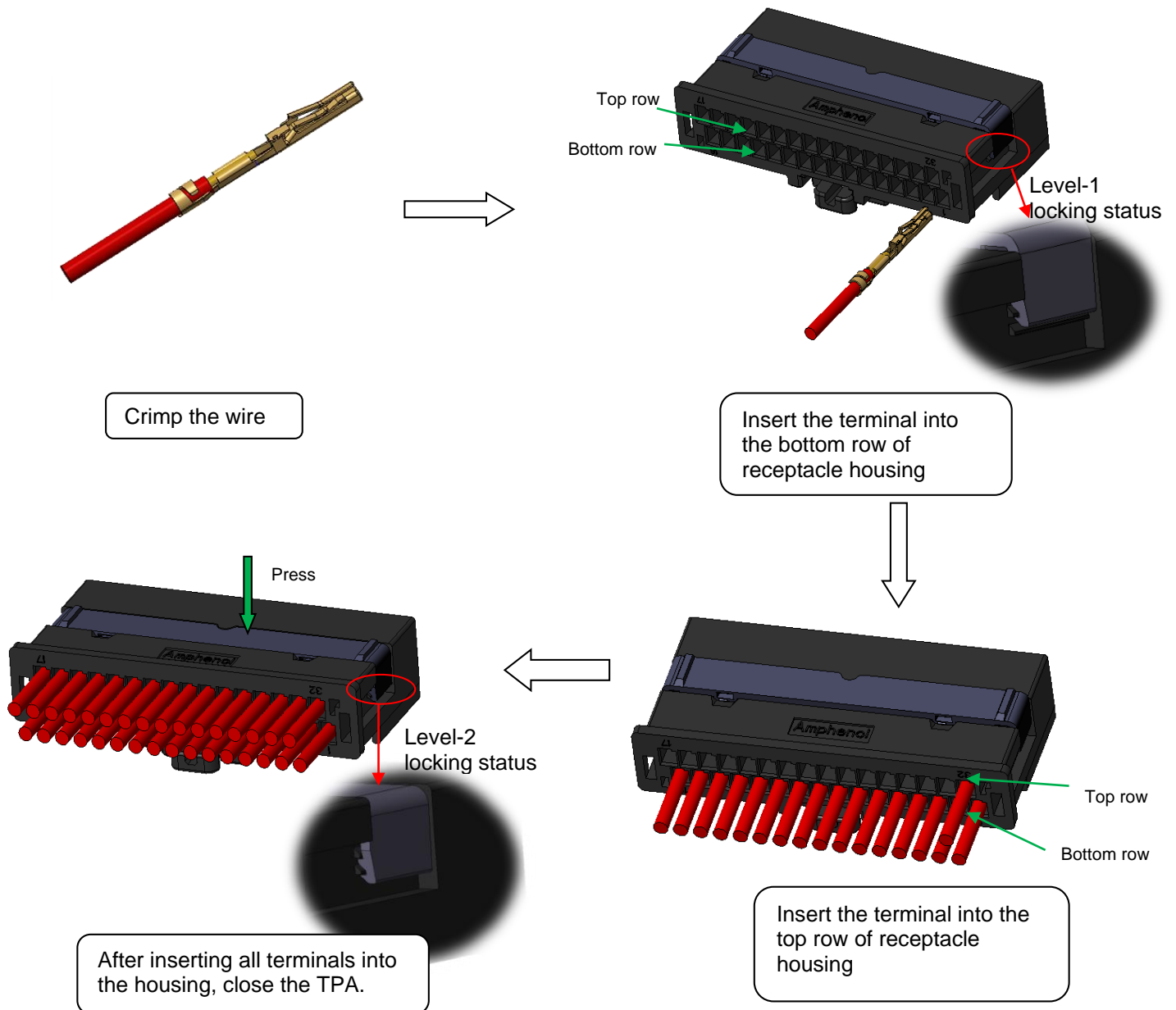

NUMBER GS-20-0594	TYPE Application Specification		
TITLE WireLock® Series Connector		PAGE 4 of 11	REVISION F
		AUTHORIZED BY Daisy Wu	DATE 07/06/2024
CLASSIFICATION UNRESTRICTED			

Please be attention to the notes below:

- 1) Make sure the receptacle terminal is well oriented for the insertion to the housing.

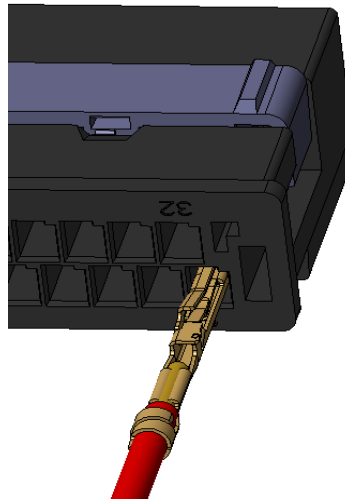

- 2) Insert the terminal into housing until hearing the sound of the locker and the front is stopped by housing. Then locking tab will be engaged the retention shoulder and prevent back out during mating. Pull back on the wire lightly and ensure the terminal is fully seated.

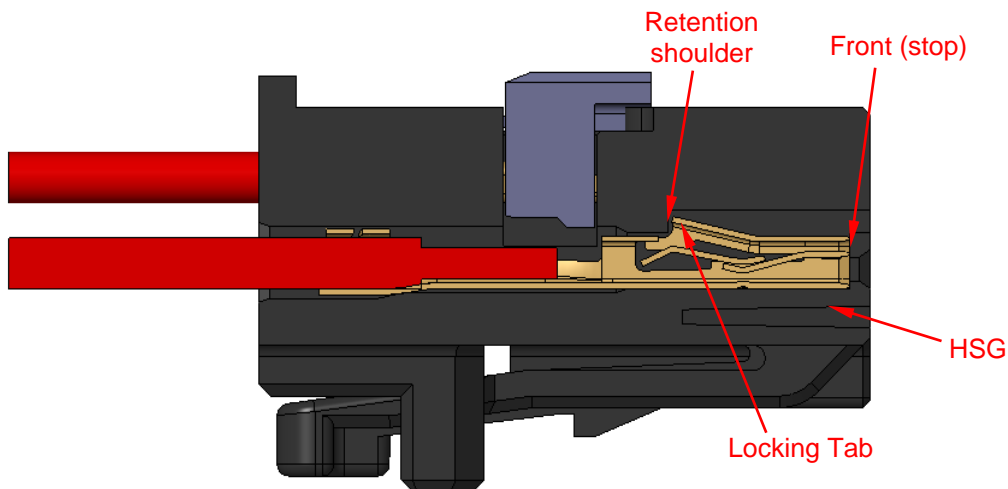

8.0 REPAIRING PROCEDURE

IF needing to take out the terminal which is inserted into the housing wrongly, take steps as bellow:

NUMBER GS-20-0594	TYPE Application Specification		
TITLE WireLock® Series Connector		PAGE 5 of 11	REVISION F
		AUTHORIZED BY Daisy Wu	DATE 07/06/2024
CLASSIFICATION UNRESTRICTED			

8.1 Insert extraction tooling into the hole of TPA to pry up the TPA to make it on level-1 locking status.

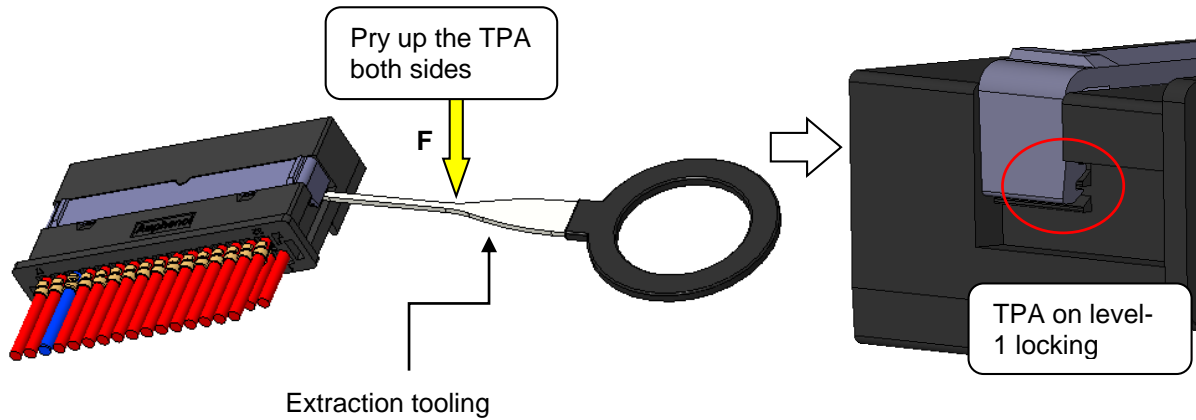

8.2 Insert extraction tooling into the hole up the socket of the terminal which is wrongly inserted to press the locking tab and make it under the retention shoulder. At the same time, pull back the terminal until it is stopped by the second shoulder of the housing.

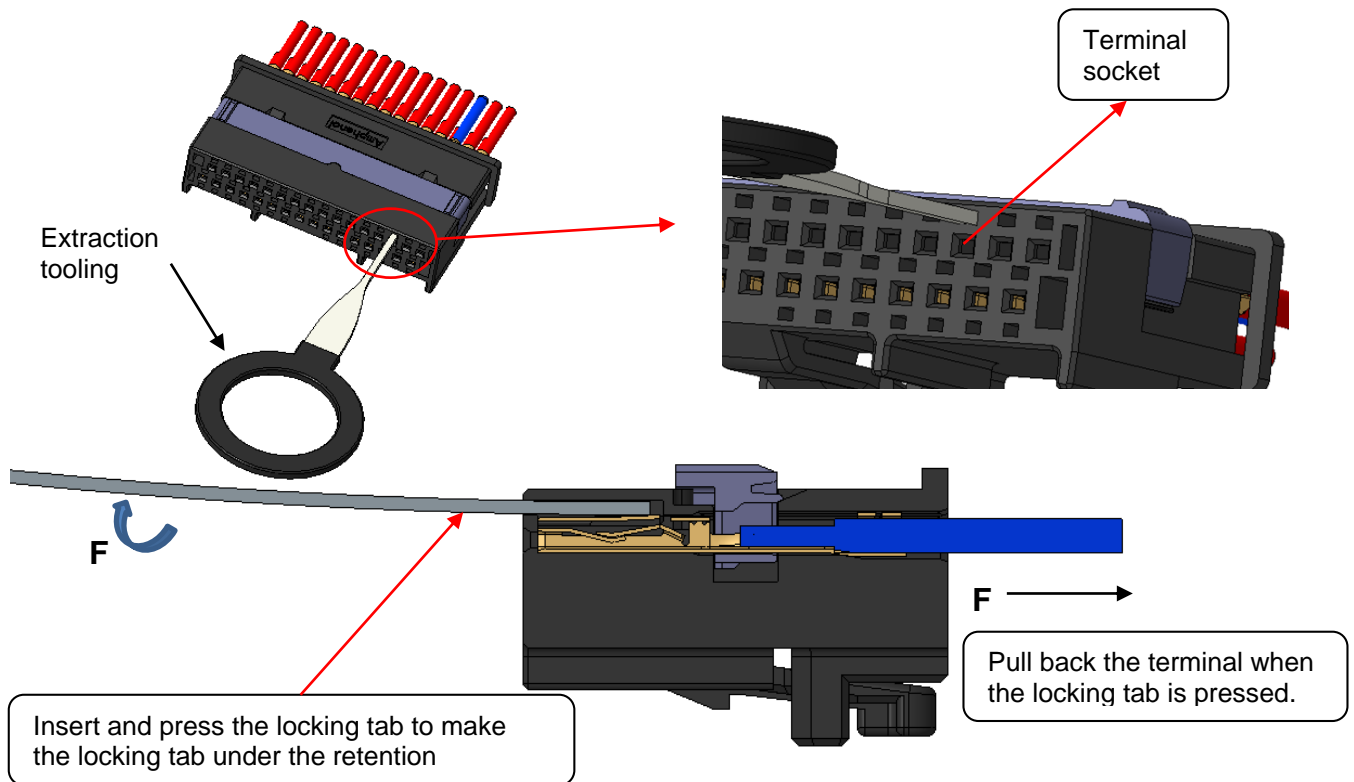

NUMBER GS-20-0594	TYPE Application Specification		
TITLE WireLock® Series Connector		PAGE 6 of 11	REVISION F
		AUTHORIZED BY Daisy Wu	DATE 07/06/2024
		CLASSIFICATION UNRESTRICTED	

8.3 When the locking tab is stopped by the second shoulder of housing, press the TPA to keep the locking tab under the second shoulder. At the same time, pull out the terminal.

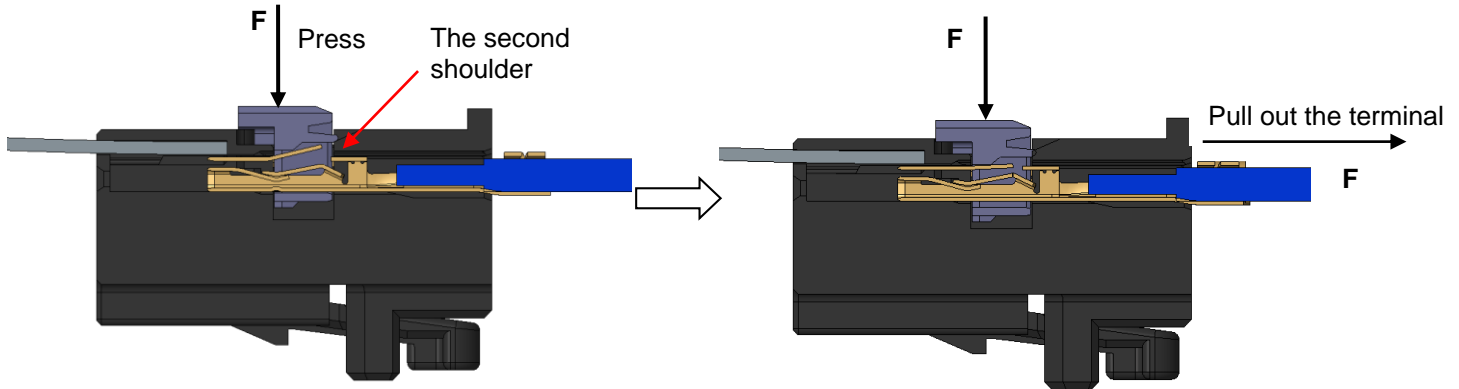

Warning: The terminal which is pulled out from the housing should be prohibited to be used again.

Terminal comparison as below.

Terminals comparison: 10153126	Remark
	The locking tab is good for good terminals .
	The locking tab is broken for terminals which is pulled out from housing. So prohibit to use the terminals.

NUMBER GS-20-0594	TYPE Application Specification		
TITLE WireLock® Series Connector		PAGE 7 of 11	REVISION F
		AUTHORIZED BY Daisy Wu	DATE 07/06/2024
		CLASSIFICATION UNRESTRICTED	

Remark: The P/N of extraction tooling is 10177368

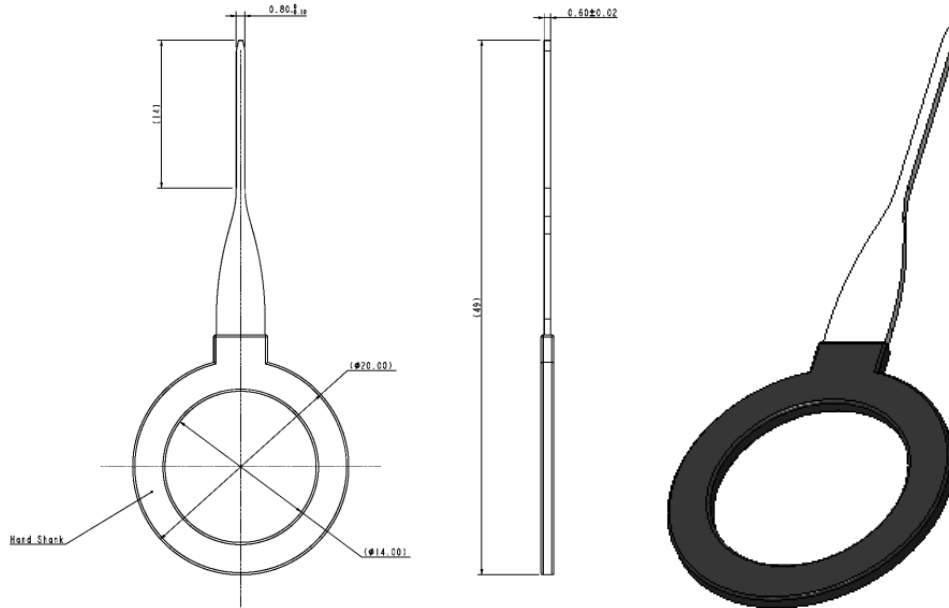

9.0 POST-APPLICATION INSPECTION PROCEDURES

9.1 Crimp height and width measurement:

9.1.1 Use Crimp Height Type Micrometers to measure crimping height.



NUMBER GS-20-0594	TYPE Application Specification		
TITLE WireLock® Series Connector		PAGE 8 of 11	REVISION F
		AUTHORIZED BY Daisy Wu	DATE 07/06/2024
		CLASSIFICATION UNRESTRICTED	

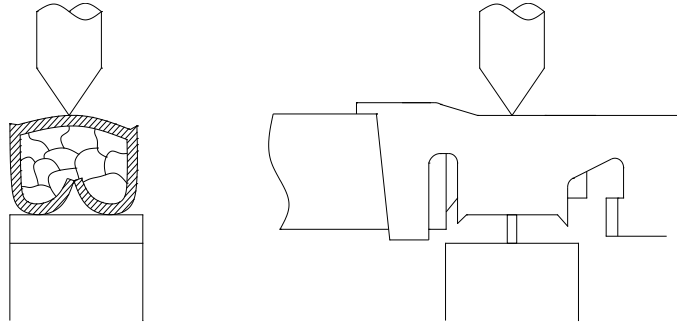

9.2 Required crimping dimensions, crimp height and width for different wire AWG are defined in Table 3 & Table 4.
(For different wire section, crimping parameters must be corrected to keep crimp area ratio to optimum)

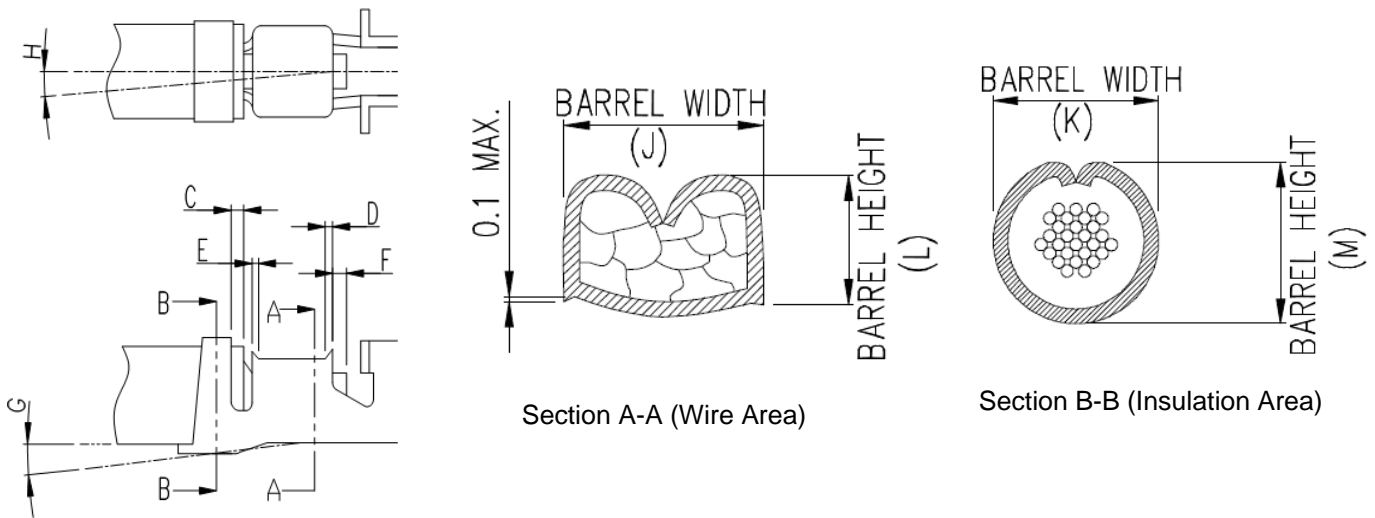

Table 3 (unit: mm)

Item	Requirement	Note
Insulation position	C 0.5 mm max.	Insulation and wire should be both visual in this area
Front bell mouth	D -	Not required
Rear bell mouth	E 0.2 - 0.5mm	
Extruded wire length	F 0.2 – 1.0mm	
Bend up / down	G ±3° max.	
Bend right / left	H ±3° max.	
Wire Crimp Compression (%)	75%~85%	

NUMBER GS-20-0594	TYPE Application Specification		
TITLE WireLock® Series Connector		PAGE 9 of 11	REVISION F
		AUTHORIZED BY Daisy Wu	DATE 07/06/2024
CLASSIFICATION UNRESTRICTED			

Table 4 (unit: mm)

Crimping Width & Height (mm)		AWG 22	AWG 24	AWG 26	AWG 28
Crimping Width (Wire barrel)	J	1.24 ± 0.04	1.23 ± 0.04	0.83 ± 0.04	-
Crimping Width (Insulation barrel)	K	1.45 Max		1.37 Max	-
Crimping Height (Wire barrel)	L	0.73 ± 0.03	0.65 ± 0.03	0.66 ± 0.03	-
Crimping Height (Insulation barrel)	M	1.49 Max		1.32 Max	-

9.3 Pullout force measurement

- 9.3.1 After crimping, pullout force measurement should be applied to ensure the performance.
- 9.3.2 Apply an axial pullout force on the wire at a rate of 25 ± 6 mm.
- 9.3.3 Pullout force should not be less than those listed in Table 5.

Table 5 (unit: N)

Wire AWG	AWG 22	AWG 24	AWG 26	AWG 28
Wire Pullout Force	50N min.	35N min.	25N min.	15N min.

9.4 Visual Inspection:

- 9.4.1 No damage, deformation on locking tabs, contact area or other portion of the terminals.
- 9.4.2 Insulation should not be crimped into wire barrel.
- 9.4.3 Wire should not be cut-off and insulation should not be broken after crimping process.

9.5 Required width dimensions:

- 9.5.1 Width dimensions should be applied to ensure the good insertion of the terminal into the housing.
- 9.5.2 During the crimp operation, the front transition area should be managed to respect the crimping widths (J) all along the wire barrel area
- 9.5.3 During the crimp operation, the rear transition area should be managed to respect the crimping widths (K) all along the insulation barrel area

NUMBER GS-20-0594	TYPE Application Specification		
TITLE WireLock® Series Connector		PAGE 10 of 11	REVISION F
		AUTHORIZED BY Daisy Wu	DATE 07/06/2024
		CLASSIFICATION UNRESTRICTED	

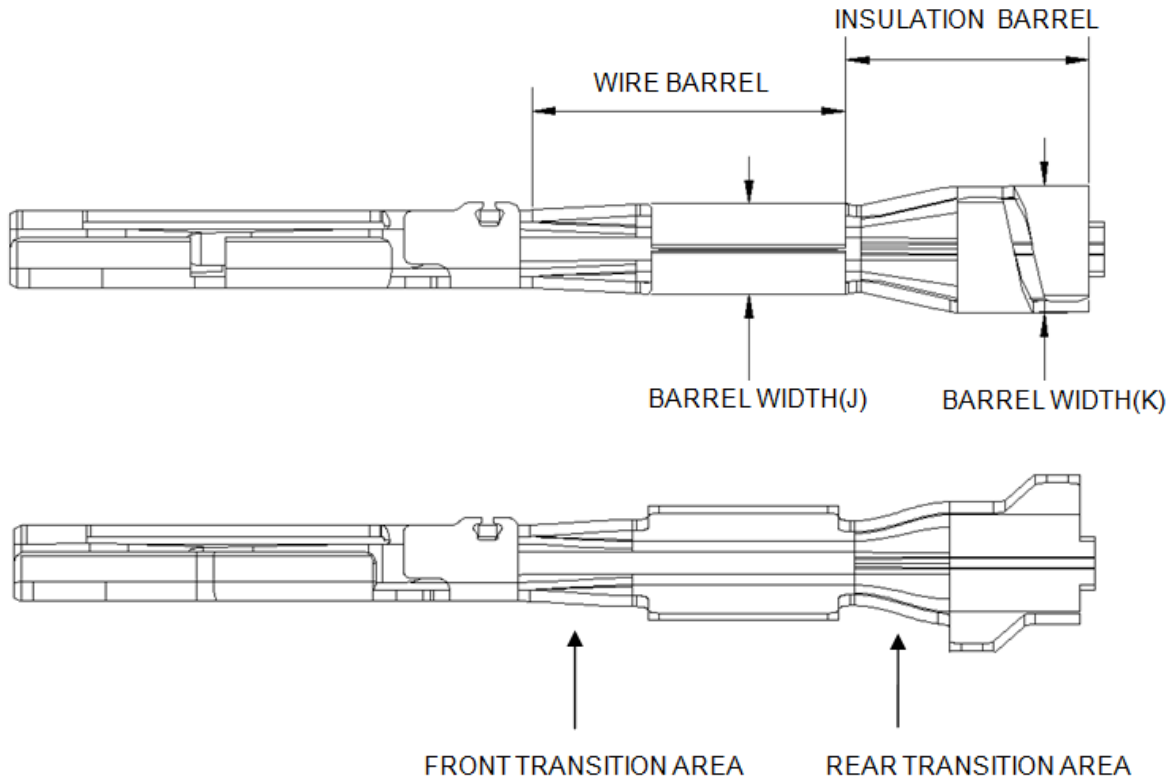

10.0 Detection Considerations:

Any inspection station after assembly detection probe diameter dimension must less than 0.43mm in operation.

Graphical representation	Remark
<p>0.35mm</p> <p>(3.50mm)</p>	<p>Probe diameter: Must less than 0.43mm Recommended: 0.35mm</p> <p>Probe insertion depth: Recommended : 3.0~4.0mm</p>
<p>>0.43mm</p>	

NUMBER GS-20-0594	TYPE Application Specification		
TITLE WireLock® Series Connector		PAGE 11 of 11	REVISION F
		AUTHORIZED BY Daisy Wu	DATE 07/06/2024
		CLASSIFICATION UNRESTRICTED	

REVISION RECORD

REV	PAGE	DESCRIPTION	EC#	DATE
A	ALL	RELEASE	-	11/17/2020
B	ALL	Add the terminal spec of crimping 26AWG wire and update the title and product series name from Minitek 1.8mm Series to WireLock® Series	ELX-N-40698	04/20/2021
C	9	Update the Crimping Width (Insulation barrel) to 1.41 ^{+/-0.04}	ELX-N-41897	08/03/2021
D	1,2,6,9	Adding 10163003 series terminal spec	ELX-N-45485	7/25/2022
E	6	Remove invalid supplier information	ELX-N-47820	03/22/2023
F	2,5,7,8,9,10	Data in Table 1 were updated to add extraction tooling and testing considerations	ELX-N-51768	07/06/2024