	TYPE APPLICATION SPECIFICATION	NUMBER GS-20-141	
TITLE Application Guide for Pwrblade+™ Press Fit and Solder Tail Plugs and Receptacles	PAGE 1 of 24	REVISION C	
	AUTHORIZED BY RAINBOW ZHAN	DATE 26 Dec. 17	
CLASSIFICATION UNRESTRICTED			

1.0 OBJECTIVE

This specification provides information and requirements regarding customer application of PwrBlade+™ Connector System. This specification is intended to provide general guidance for application process development. It is recognized that no single application process will work under all customer scenarios and that customers will develop their own application processes to meet their needs. However, if these application processes differ greatly from the one recommended, FCI cannot guarantee results.

2.0 SCOPE

This specification provides information and requirements regarding customer application of PwrBlade+™ Connector System. The product possibilities for configuration including:

- Right angle press fit and solder tail receptacles
- Right angle press fit and solder tail plugs
- Vertical press fit and solder tail receptacles
- Vertical press fit and solder tail plugs

3.0 GENERAL

3.1 This document is meant to be an application guide. If information varies from that in the product drawings and specifications, the drawings and specifications take precedence.

	TYPE	APPLICATION SPECIFICATION		NUMBER	GS-20-141	
	TITLE			PAGE	REVISION	
Application Guide for Pwrblade+™ Press Fit and Solder Tail Plugs and Receptacles			2 of 24		C	
			AUTHORIZED BY		DATE	
			RAINBOW ZHAN		26 Dec. 17	
			CLASSIFICATION			
			UNRESTRICTED			

3.2 This document covers the following sections:

<u>Paragraph</u>	<u>Title</u>	<u>Page</u>
1.0	Objective	1
2.0	Scope	1
3.0	General	1
4.0	Drawings and Applicable documents	3
5.0	Introduction	3
6.0	Requirements	4
6.1	Safety	4
6.2	Limitations	4
6.3	Material	5
6.4	Storage	5
6.5	PCB Board	6
6.6	Connector Placement	12
6.7	Mounting Hardware	13
6.8	Soldering	13
6.9	Connector Mating	15
6.10	Circuit Testing	20
6.11	Connector Unmating	21
6.12	Connector Removal	21
6.13	Repair	21
7.0	Tooling	22
8.0	Product Part Number Assignments	23

	TYPE	NUMBER	
	APPLICATION SPECIFICATION	GS-20-141	
TITLE Application Guide for Pwrblade+™ Press Fit and Solder Tail Plugs and Receptacles	PAGE	3 of 24	REVISION
	AUTHORIZED BY	RAINBOW ZHAN	DATE
			26 Dec. 17
	CLASSIFICATION	UNRESTRICTED	

4.0 DRAWINGS AND APPLICABLE DOCUMENTS

- FCI PRODUCT SPECIFICATION GS-12-658
- FCI PRODUCT DRAWINGS

Product drawings and FCI's GS-12-658 Product Specification are available at www.fci.com. In the event of a conflict between this application specification and the drawing, the drawing will take precedence. Customers are advised to refer to the latest revision level of FCI product drawings for appropriate details.

5.0 INTRODUCTION

PwrBlade+™ has two options for connection to Printed Circuit Boards: Press Fit and Solder to Board. The press fit and solder tail configuration are available all plugs and receptacles. The PwrBlade+™ Solder to Board Power (High Power & Low Power = H & L) and Signal Contacts are compatible with several soldering processes, including wave soldering. They are versatile with many configurations to fit the individual needs of the client and are less expensive than press fit. The Press Fit connection eliminates the need for soldering, achieving a connection to the board through the normal forces between the press fit tail and the plated through hole. The number of signal and power contacts is customer dependent with three choices of pitches between power contacts. PwrBlade+™ has high current carrying capabilities ideal for data communications and data processing and is well suited for a wide variety of applications, such as SSI server power supplies, Fault-tolerant computers, Modular and hot-swap redundant N+1 power distribution systems and uninterruptible power systems (UPS).

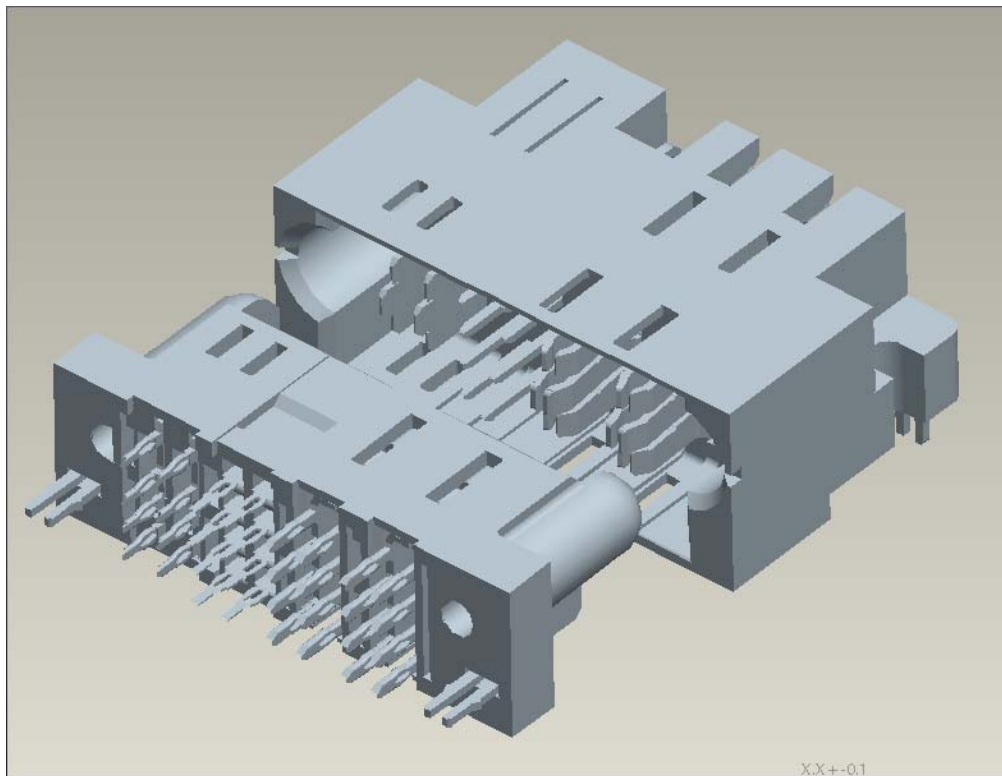

**Figure 1 – Exploded view of a Right Angle Plug mating
With a Vertical Receptacle.**

Modules are available with contact centerline spacing and related voltage rating listed in the following table:

Copyright 2000 FCI USA, INC.

	TYPE	APPLICATION SPECIFICATION		NUMBER	GS-20-141
	TITLE			PAGE	REVISION
Application Guide for Pwrblade+™ Press Fit and Solder Tail Plugs and Receptacles			4 of 24		C
			AUTHORIZED BY		DATE
			RAINBOW ZHAN		26 Dec. 17
			CLASSIFICATION		
			UNRESTRICTED		

MODULE TYPE	CONFIGURATION INDICATION	CONTACT	
		CENTERLINE SPACING	VOLTAGE RATING
High Power	ACP	7.62[.300"]	645
	HP	6.35[.250"]	466
	HDP	5.08[.200"]	295
Low Power	LP	2.92[.115"]	363
Signal	S	2.54[.100"]	88

Figure 1

The maximum overall length allowed for the connector is 203 [8]. Combinations of up to 36 power contacts and 148 signal contacts can be used-provided the maximum allowable length is not exceeded.

End modules and center modules are available with features that provide blind mating, misalignment, and polarization. End modules contain a guide post, guide hole, or latch receiver with key slot and a retention clip, and/or mounting hole, and center modules contain a retention clip or mounting hole. End modules without guides are also available. Guides (posts on receptacle and holes in plug) have rounded edges for ease of mating and are offset to prevent improper mating of connectors. The latch receiver with key slot ensures proper orientation of connectors when mating and accidental back-out of the connector. The retention clips help to align the connector to the pc board for installation then secure the connector for soldering. The 3.05 [.120] diameter mounting holes (which accept commercially-available standard screws) are also used to secure the connector to the pc board. The connectors are supplied in tray form for manual placement.

The connectors feature standoffs (one located at each contact) to facilitate pc board cleaning after soldering. Convection windows and cored lances located on the housing provide air flow for power modules.

6.0 REQUIREMENTS

6.1 Safety

Don't stack product shipping containers so high that the containers buckle or deform.

6.2 Limitations

The connectors are designed to operate in a temperature range of -40°C to 125°C [-40° to 257°F].

Voltage ratings for these connectors are based upon UL – 60950 -1 Second Edition Tale 2N.

Voltage ratings according to Minimum Creep Distance (MCD) are given in Figure 2.

	TYPE	APPLICATION SPECIFICATION		NUMBER	GS-20-141	
	TITLE			PAGE	REVISION	
Application Guide for Pwrblade+™ Press Fit and Solder Tail Plugs and Receptacles			5 of 24		C	
			AUTHORIZED BY		DATE	
			RAINBOW ZHAN		26 Dec. 17	
			CLASSIFICATION			
			UNRESTRICTED			

PwrBlade+ Maximum Working Voltage Vs. Minimum Creep Distance (Reference UL 60950-1 Second Edition Table 2N)							
Figure 2	Type	Contact Pitch	Pollution Degree (office Environment)	Material Group (Base on UL Rating)	MCD (mm)	Maximum Working Voltage (AC RMS)	Maximum Working Voltage (DC/AC Peak)
	Signal	2.54 [.100"]	2	II	0.94	88	124
	Signal – High Power	3.81 [.150"]			1.98	281	397
		4.45 [.175"]			2.62	376	531
		5.08 [.200"]			3.25	456	644
		5.72 [.225"]			3.89	541	764
		6.35 [.250"]			4.52	633	895
		Signal – Low Power			2.73 [.107"]	2.22	322
	3.37 [.132"]				2.86	407	575
	4.00 [.157"]				3.49	486	687
	4.64 [.182"]				4.13	576	814
	High Power	5.27 [.207"]			4.76	670	947
		5.08 [.200"]			2.06	295	417
		6.35 [.250"]			3.33	466	659
	High Power – Low Power	7.62 [.300"]			4.60	645	912
		4.00 [.157"]			2.28	330	467
		4.64 [.182"]			2.92	415	586
		5.27 [.207"]			3.55	493	697
		5.91 [.232"]			4.19	585	827
	Low Power	6.54 [.257"]			4.82	679	960
		2.92 [.115"]			2.52	363	513

Figure 2

6.3 Material

The housing is made of glass filled high temperature nylon, UL 94V-0, with an oxygen index of 49%. The contacts are made of high-conductivity copper alloy underplated with nickel and plated with gold or palladium nickel; solder tines are plated with tin over nickel. Retention clips are made of plated copper alloy.

6.4 Storage

6.4.1 Ultraviolet Light

Prolonged exposure to ultraviolet light may deteriorate the chemical composition used in the connector material

6.4.2 Shelf Life

The connectors should remain in the shipping containers until ready for use to prevent deformation to the contacts. The connectors should be used on a first in, first out basis to avoid storage contamination that could adversely affect performance.

	TYPE	APPLICATION SPECIFICATION		NUMBER	GS-20-141	
	TITLE			PAGE	REVISION	
Application Guide for Pwrblade+™ Press Fit and Solder Tail Plugs and Receptacles			6 of 24		C	
			AUTHORIZED BY		DATE	
			RAINBOW ZHAN		26 Dec. 17	
			CLASSIFICATION			
			UNRESTRICTED			

6.4.3 Chemical Exposure

Don't store connectors near any chemical listed below as they may cause stress corrosion cracking in the contacts.

Alkalies	Ammonia	Citrates	Phosphates	Citrates	Sulfur Compounds
Amines	Carbonates	Nitrites	Sulfur Nitrites		Tartrates

6.5 PC Board

6.5.1 Material and Thickness

The pc board material shall be glass epoxy (FR-4 or G-10). The pc board thickness shall be as stated in Figure 3.

PC BOARD THICKNESS			
CONNECTOR WITH PRESS-FIT CONTACTS	CONNECTOR WITH SOLDER TYPE CONTACTS		
	2.28 ± 0.40 TAIL LENGTH	3.43 ± 0.40 TAIL LENGTH	4.19±0.40 TAIL LENGTH
1.35 [.053] Min	1.40~1.75 [.055~.069]	2.11~2.62 [.083~.103]	2.92~3.43 [.115~.135]

Figure 3

6.5.2 Hole Dimensions and Durability

The contact holes must be drilled and plated through to specific dimensions to prevent stubbing during placement of the connector on the pc board and to ensure optimum continuity for circuits after soldering. If applicable, holes for the retention clips or mounting hardware may be used with or without plated through holes. The drilled hole size, plating types, plating thickness, and finished hole size must be as stated to provide unrestricted insertion. See Figure 4.

For connectors with press-fit contacts, the pc board holes can't withstand connector removal more than three times. The radius of any board hole must not increase more than 0.038 [.0015] or decrease less than 0.0508 [.002].

6.5.3 Land/pad size

The pc board land/pad size is given in Figure 4.

	TYPE	APPLICATION SPECIFICATION		NUMBER	GS-20-141	
	TITLE			PAGE	REVISION	
Application Guide for Pwrblade+™ Press Fit and Solder Tail Plugs and Receptacles			7 of 24		C	
			AUTHORIZED BY		DATE	
			RAINBOW ZHAN		26 Dec. 17	
			CLASSIFICATION			
			UNRESTRICTED			

	mm	inch
Drilled hole diameter	1.151 +/- 0.025	0.0453 +/- 0.001
Plated hole diameter	1.016 +/- 0.07	0.040 +/- 0.003
Copper plating	0.051 +/- 0.025	0.002 +/- 0.001
Tin/Lead plating	0.007	0.0003
Land/Pad size	1.727 +/- 0.064	0.068 +/- 0.0025

Figure 4

Typical PC Board Land/Pad Lay-out For Reference Only

Dimensions are mm/inch

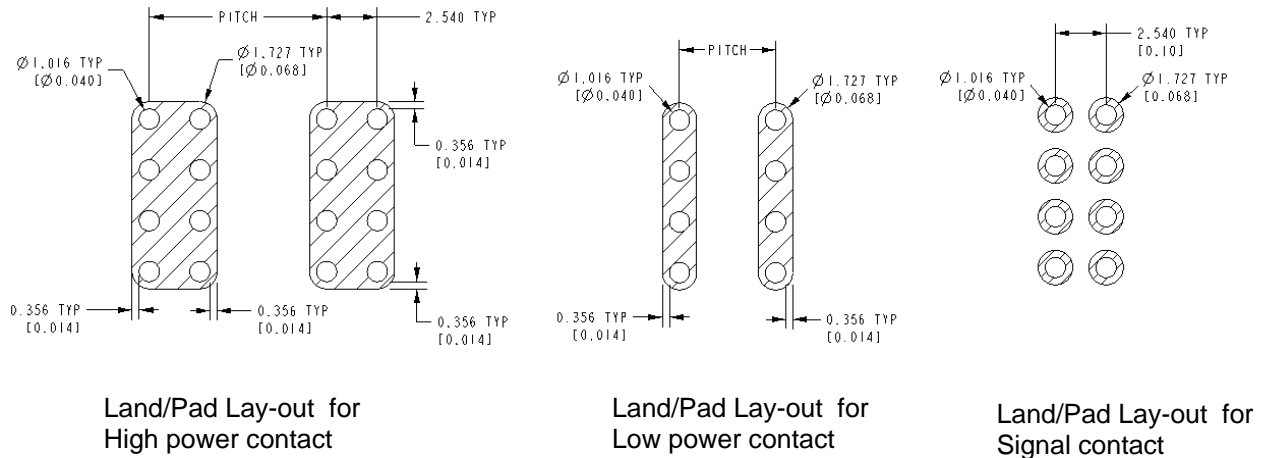

NOTE: Above PCB layout is just for PF and solder to board type (wave process), can not meet the PIP process.

	TYPE	NUMBER	
	APPLICATION SPECIFICATION	GS-20-141	
TITLE Application Guide for Pwrblade+™ Press Fit and Solder Tail Plugs and Receptacles	PAGE	8 of 24	REVISION
	AUTHORIZED BY	RAINBOW ZHAN	DATE
			26 Dec. 17
	CLASSIFICATION	UNRESTRICTED	

6.5.4 Layout

The holes in the pc board must be precisely located to ensure proper placement and optimum performance of the connector. The pc board layout must be designed using the dimensions provided on the customer drawing for the specific connector. A sample of the recommended pc board layout is shown in Figure 5.

Sample Recommended PC Board Layout

Right Angle Plug (With Retention Clips)

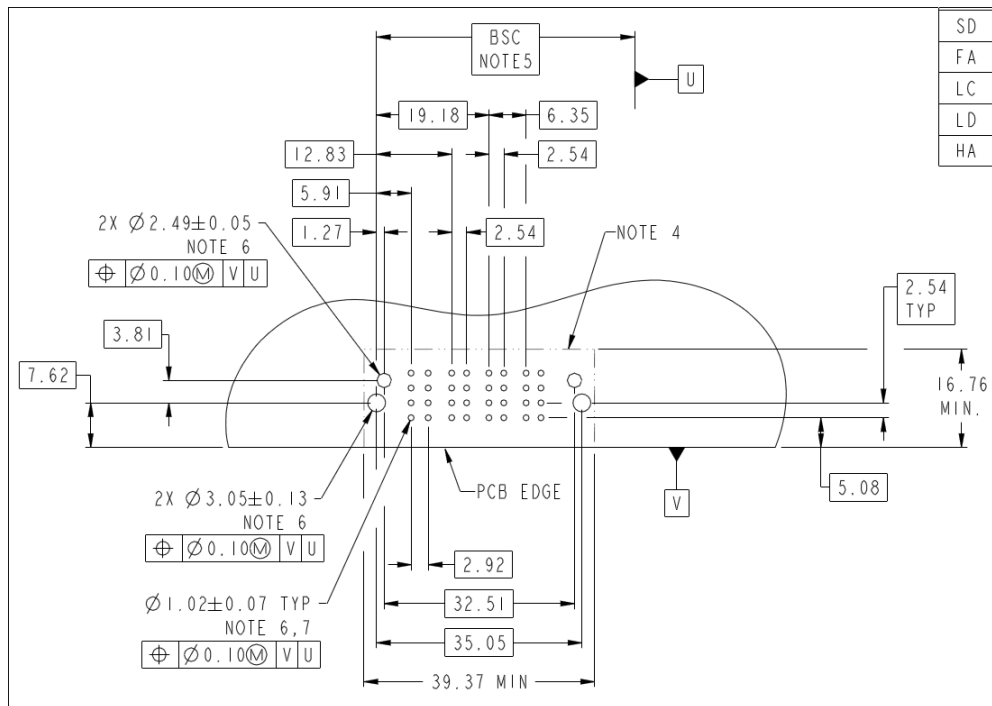
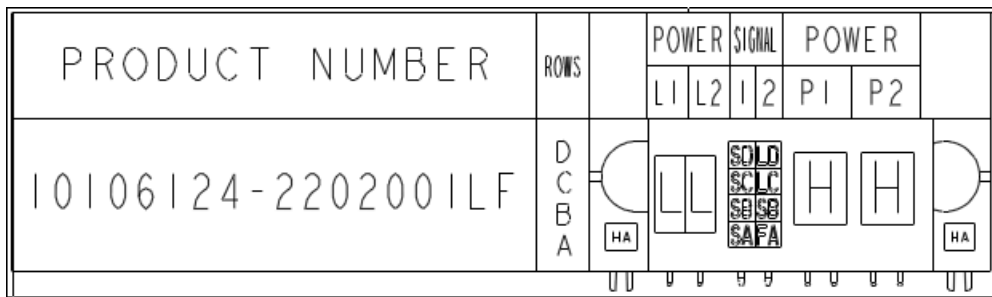

	TYPE APPLICATION SPECIFICATION	NUMBER GS-20-141	
	TITLE Application Guide for Pwrblade+™ Press Fit and Solder Tail Plugs and Receptacles	PAGE 9 of 24	REVISION C
		AUTHORIZED BY RAINBOW ZHAN	DATE 26 Dec. 17
		CLASSIFICATION UNRESTRICTED	

Vertical Receptacle (One Side With Retention Clips)

PRODUCT NUMBER	ROWS		POWER	SIGNAL	POWER	
10106131-2202001LF		D C B A		P2	P1	2
			H	H	S	S
			S	S	L	L
			S	S		
						HA

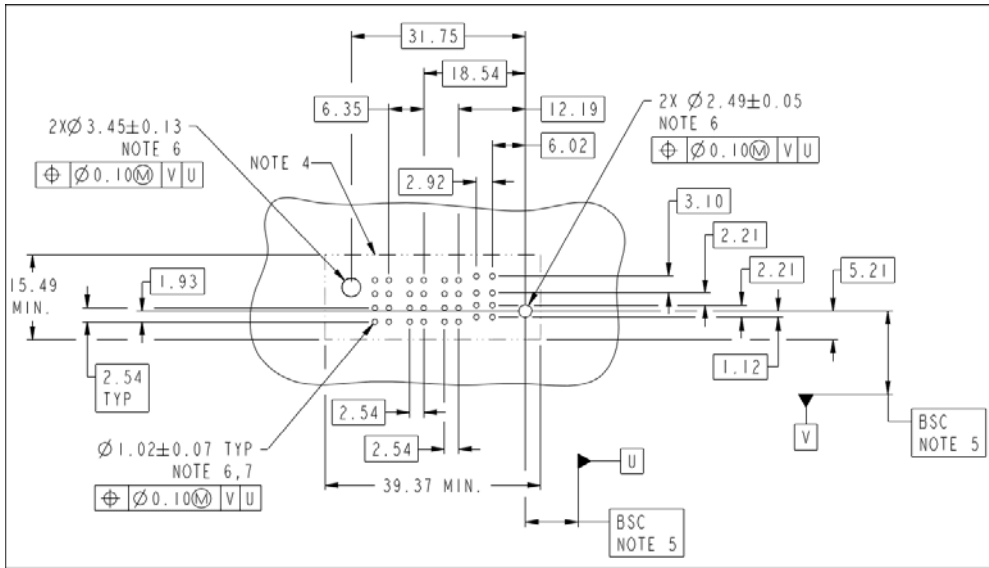

- 4) DENOTES CONNECTOR KEEP OUT ZONE.
- 5) DATUM AND BASIC DIMENSIONS WERE ESTABLISHED BY CUSTOMER.
- 6) ALL HOLE DIAMETERS ARE FINISHED HOLE SIZES.
- 7) 1.15 ± 0.025MM DRILLED HOLE PLATED WITH 0.00762MM MIN Sn OVER 0.0254-0.0762MM Cu PLATING TO ACHIEVE A 1.02 ± 0.07MM HOLE.

Figure 5

("Power and Signal traces inside the connector zone seen in Figure 5 need to be coated or under solder mask to protect against oxidation and minimize wear or damage during assembly and handling.")

	TYPE APPLICATION SPECIFICATION	NUMBER GS-20-141	
	TITLE Application Guide for Pwrblade+™ Press Fit and Solder Tail Plugs and Receptacles	PAGE 10 of 24	REVISION C
		AUTHORIZED BY RAINBOW ZHAN	DATE 26 Dec. 17
		CLASSIFICATION UNRESTRICTED	

6.5.5 Spacing

Care must be used to avoid interference between adjacent connectors and other components. In addition, space allowed between pc boards for mating of connectors must be considered when determining distance between pc boards. The minimum allowable distance needed between connector to ensure full mating of connectors and the allowable distance between pc boards with connectors fully mated is provided in Figure 6.

Allowable Distance Between Connectors

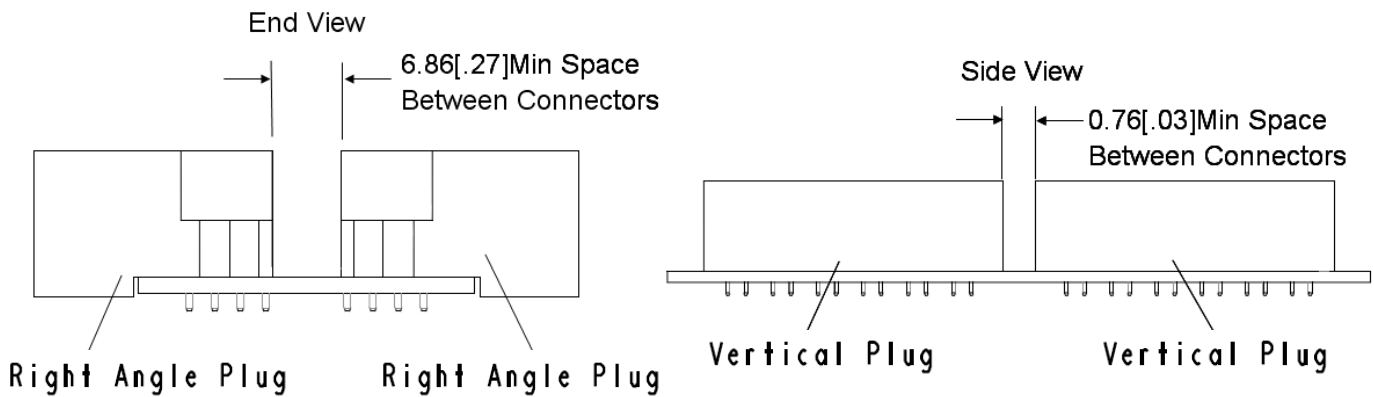

Allowable Distance Between PC Boards

Notes: Connectors must be fully mated

A. Right Angle Receptacle to Right Angle Plug

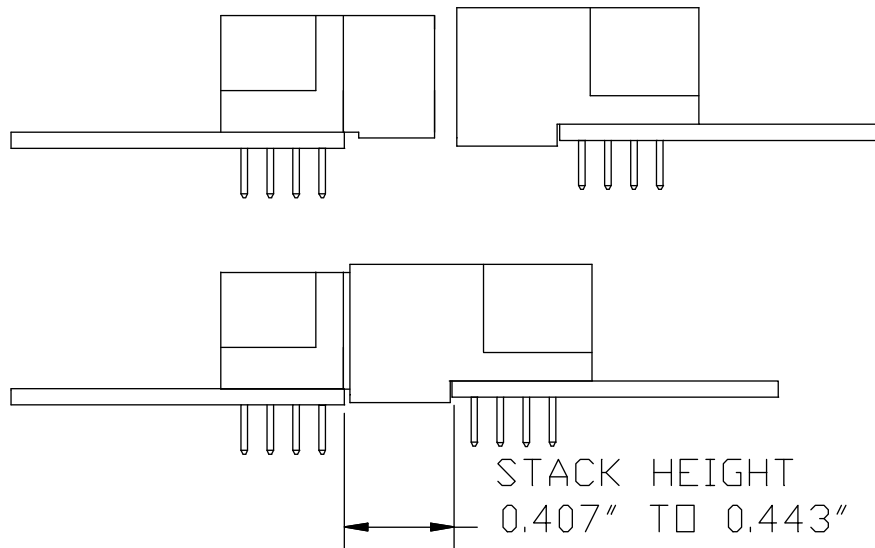

	TYPE APPLICATION SPECIFICATION	NUMBER GS-20-141	
	TITLE Application Guide for Pwrblade+™ Press Fit and Solder Tail Plugs and Receptacles	PAGE 11 of 24	REVISION C
		AUTHORIZED BY RAINBOW ZHAN	DATE 26 Dec. 17
		CLASSIFICATION UNRESTRICTED	

B. Vertical Receptacle to Right Angle Plug

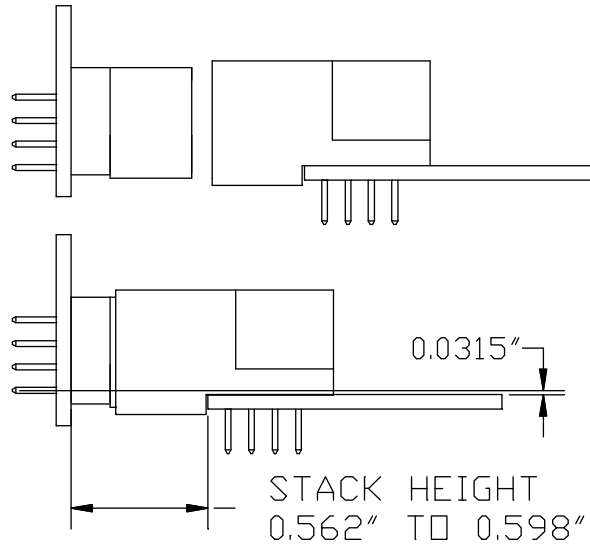

C. Vertical Receptacle to Vertical Plug

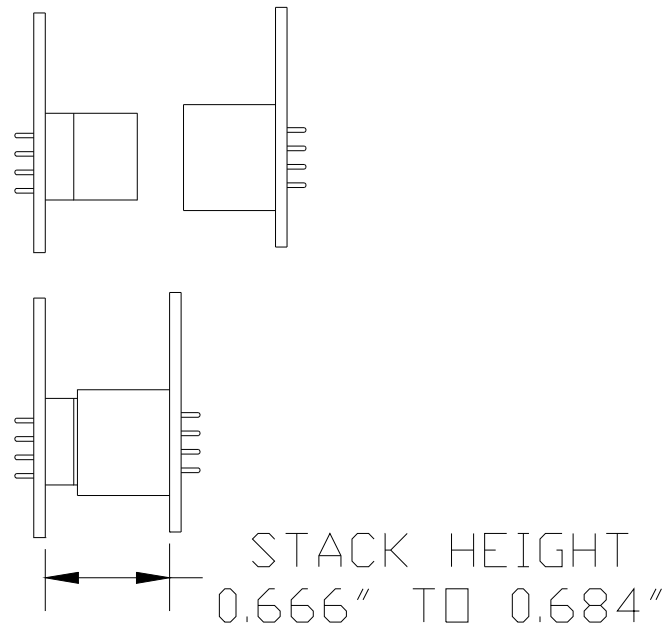

D. Right Angle Receptacle to Vertical Plug

	TYPE APPLICATION SPECIFICATION	NUMBER GS-20-141	
	TITLE Application Guide for Pwrblade+™ Press Fit and Solder Tail Plugs and Receptacles	PAGE 12 of 24	REVISION C
	AUTHORIZED BY RAINBOW ZHAN	DATE 26 Dec. 17	
	CLASSIFICATION UNRESTRICTED		

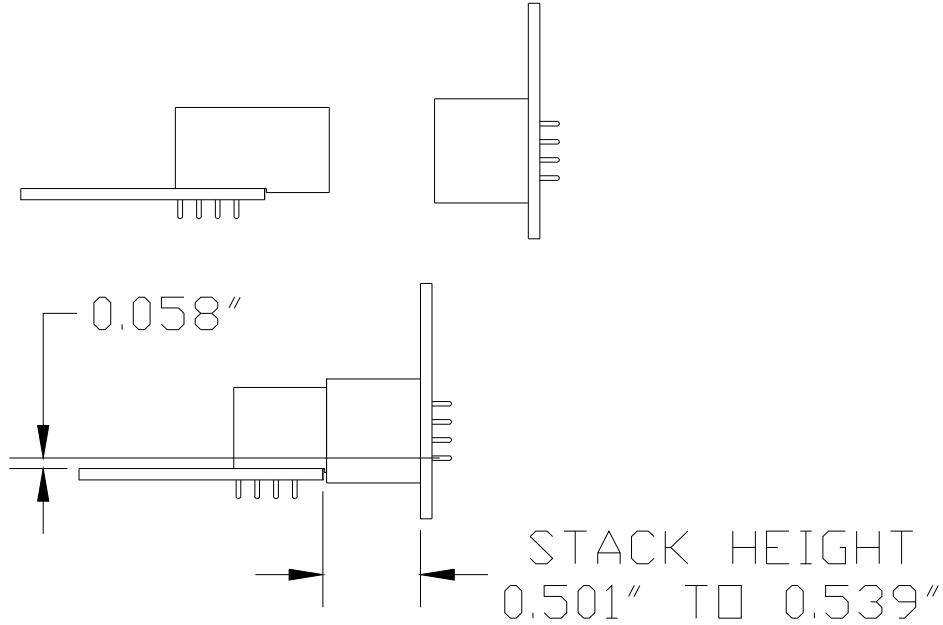

Figure 6

6.6 Connector Placement

Connectors should be handled only by the housing to avoid deformation, contamination, or damage to the contacts.

6.6.1 Registration

When placing connectors on the pc board, contacts and, if applicable, retention clips or mounting holes must be aligned and started into the matching holes before seating the connector onto the board.

6.6.2 Insertion Force

The force required to seat the connector with press-fit contacts or retention clips onto the pc board can be calculated by:

Insertion force N [lbs.] =

Number of connector press-fit contacts X maximum insertion force per contact

Insertion force N [lbs.] =

Number of connector retention clips X maximum insertion force per retention clips

The maximum amount of insertion force per press-fit contact and retention clips is given in Figure 7.

MAXIMUM INSERTION FORCE (N [lbs.])

	TYPE	APPLICATION SPECIFICATION		NUMBER	GS-20-141	
	TITLE			PAGE	REVISION	
Application Guide for Pwrblade+™ Press Fit and Solder Tail Plugs and Receptacles			13 of 24		C	
			AUTHORIZED BY		DATE	
			RAINBOW ZHAN		26 Dec. 17	
			CLASSIFICATION			
			UNRESTRICTED			

PER PRESS-FIT HIGH POWER CONTACT	PER PRESS-FIT LOW POWER CONTACT	PER PRESS-FIT SIGNAL CONTACT		PER RETENTION CLIP
890 [200]	445 [100]	Plug	93.4 [21]	27 [6]
		Receptacle	27 [6]	

Figure 7

6.7 Mounting Hardware

Connectors with mounting holes can be secured to the pc board before soldering using commercially-available standard screws. The screw size and maximum torque (applied to the mating face of the connector) is provided in Figure 8.

Typically, this method of mounting (or hold-down) serves connectors with solder type contacts and without retention clips.

MOUNTING HOLE DIAMETER	SCREW		MAXIMUM TORQUE N-m [lb- in.] (Applied to Mating Face)
	SIZE	HEAD DIAMETER (Maximum)	
3.05 [.120]	No. 4	7.37 [.290]	0.57 [5]

Figure 8

6.8 Soldering

Observe guidelines and procedures when soldering contacts. Contact solder tines must be soldered, cleaned, and dried according to the following:

6.8.1 Flux Selection

Contact solder tines must be fluxed prior to soldering with a mildly active, rosin base flux. Selection of the flux will depend on the type of pc board and other components mounted on the board. Additionally, the flux must be compatible with the wave solder line, manufacturing, health, and safety requirements. Flux that is compatible with these connectors are provided in Figure 9.

FLUX TYPE	ACTIVITY	RESIDUE	COMMERCIAL DESIGNATION	
			KESTER	ALPHA
RMA	Mild	Noncorrosive	186	611

Figure 9

6.8.2 Process

The connectors can be soldered using wave soldering or equivalent soldering techniques. It is recommended using tin or tin-lead solder for these connectors. The temperatures and exposure time shall be as specified in Figure 10.

SOLDERING PROCESS	WAVE TEMPERATURE	TIME (At Maximum Temperature)
Wave	265 °C [509 °F]	10 Seconds

Figure 10

6.8.3 Cleaning

	TYPE	APPLICATION SPECIFICATION		NUMBER	GS-20-141	
	TITLE			PAGE	REVISION	
Application Guide for Pwrblade+™ Press Fit and Solder Tail Plugs and Receptacles			14 of 24		C	
			AUTHORIZED BY		DATE	
			RAINBOW ZHAN		26 Dec. 17	
			CLASSIFICATION			
			UNRESTRICTED			

After soldering, removal of fluxes, residues, and activators is necessary. Consult with the supplier of the solder and flux for recommended cleaning solvents. Cleaners must be free of dissolved flux and other contaminants. Common cleaning solvents that will not affect connectors for the time and temperature specified are listed in Figure 11.

Consideration must be given to toxicity and other safety requirements recommended by the solvent manufacturer. Refer to the manufacturer's Material Safety Data Sheet (MSDS) for characteristics and handling of cleaners. Trichloroethylene and Methylene Chloride is not recommended because of harmful occupational and environmental effects. Both are carcinogenic (cancer-causing).

Even when using "no clean" solder paste, it is imperative that the contact interface be kept clean of flux and residue, since it acts as an insulator. Flux may migrate under certain conditions with elevated temperatures and therefore, cleaning is necessary.

CLEANER		TIME (Minutes)	TEMPERATURE (Maximum)
NAME	TYPE		132 °C [270 °F]
ALPHA 2110	Aqueous	1	100 °C [212 °F]
BIOACT EC-7	Solvent	5	100 °C [212 °F]
BIOACT EC-7	Solvent	5	Ambient Room
Butyl CARBITOL	Solvent	1	100 °C [212 °F]
Isopropyl Alcohol	Solvent	5	100 °C [212 °F]
KESTER 5778	Aqueous	5	100 °C [212 °F]
KESTER 5779	Aqueous	5	100 °C [212 °F]
LONCOTERGE 520	Aqueous	5	100 °C [212 °F]
LONCOTERGE 530	Aqueous	5	100 °C [212 °F]
Terpene Solvent	Solvent	5	100 °C [212 °F]

(ALPHA is a trademark of Cookson Group, Inc.

CARBITOL and LONCOTERGE are trademarks of Union Carbide Corp.

BIOACT is a trademark of Petroferm, Inc.

KESTER is a trademark of Kester, Inc.)

Figure 11

6.8.4 Drying

When drying cleaned connectors and pc boards, make certain that temperature limitations are not exceeded: -40°C to 105°C [-40°F to 221°F]. Excessive temperatures may cause housing degradation.

	TYPE	APPLICATION SPECIFICATION		NUMBER	GS-20-141	
	TITLE			PAGE	REVISION	
Application Guide for Pwrblade+™ Press Fit and Solder Tail Plugs and Receptacles			15 of 24		C	
			AUTHORIZED BY		DATE	
			RAINBOW ZHAN		26 Dec. 17	
			CLASSIFICATION			
			UNRESTRICTED			

6.9 Connector Mating

Connectors should be handled only by the housing to avoid deformation, contamination, or damage to the contacts.

6.9.1 Polarization

For connectors with guides, polarization is provided by matching the guides of mating connectors. For connectors with latch receivers or without guides, polarization is provided by matching the mating alignment keys with the key slots of mating connectors.

6.9.2 Mating Force

The maximum amount of mating force per contact is given in Figure 12.

CONTACT	MAXIMUM MATING FORCE PER CONTACT
High Power	5N [18 ounce]
Low power	2N [7.2 ounce]
Signal	1N [3.6 ounce]

Figure 12

6.9.3 Mating Length

Contact mating lengths available for the connectors are listed in Figure 13.

CONNECTOR	CONTACT MATING LENGTH		
	High Power Contact	Low Power Contact	Signal Contact
Receptacle	Standard and MFBL(Pre-Mate)	Standard	Standard
Plug	Standard	Standard, MFBL, and MLBF(Post Mate)	Standard, MFBL, MLBF and MLBF2

Figure 13

6.9.4 Wipe Length

The wipe length at the level of mating for power and signal contacts is listed in Figure 14.

	TYPE	APPLICATION SPECIFICATION		NUMBER	GS-20-141			
	TITLE	Application Guide for Pwrblade+™ Press Fit and Solder Tail Plugs and Receptacles			PAGE	16 of 24	REVISION	C
				AUTHORIZED BY	RAINBOW ZHAN		DATE	26 Dec. 17
				CLASSIFICATION	UNRESTRICTED			

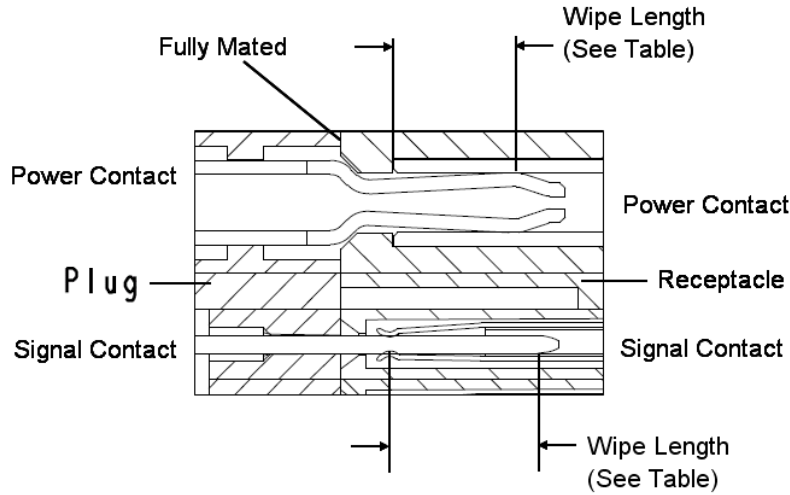

CONTACT	MATING LENGTH	MATING LEVEL	WIPE LENGTH	REMARK
High Power	MFBL (Pre-Mate)	1	5.30[.209]	Normal
	Standard	2	4.35[.171]	Normal
Low Power	MFBL (Pre-Mate)	2	4.75[.187]	Normal
	Standard	3	3.60[.142]	Normal
	MLBF (Post Mate)	4	2.00[.079]	Normal
Signal	MFBL (Pre-Mate)	1	5.80[.228]	Normal
	Standard	2	4.75[.187]	Normal
	MLBF (Post Mate)	3	3.60[.142]	Normal
	MLBF2 (Post Mate)		2.50[.098]	Customized

Figure 14

6.9.5 Sequencing

The connectors provide sequencing among contacts with 5 mating levels. The offset distance, measured from the receptacle mating face to the plug mating face at the point of electrical engagement, depends on the contact (power or signal) and mating length (standard, MFBL, or MLBF) of the mating connectors. The offset distance at the level of mating for power and signal contacts is listed in Figure 15.

CONTACT	MATING LENGTH	MATING LEVEL	OFFSET DISTANCE	
			Dimension	Nominal
High Power	MFBL (Pre-Mate)	1	A	5.30 [.209]
	Standard	2	B	4.35 [.171]
Low Power	MFBL (Pre-Mate)	2	C	4.75 [.187]
	Standard	3	D	3.60 [.142]
	MLBF (Post Mate)	4	E	2.00 [.079]
Signal	MFBL (Pre-Mate)	1	F	5.80 [.228]
	Standard	2	C	4.75 [.187]
	MLBF (Post Mate)	3	D1	3.60 [.142]
	MLBF2 (Post Mate)		D2	2.50 [.098]

	TYPE APPLICATION SPECIFICATION	NUMBER GS-20-141	
	TITLE Application Guide for Pwrblade+™ Press Fit and Solder Tail Plugs and Receptacles	PAGE 17 of 24	REVISION C
	AUTHORIZED BY RAINBOW ZHAN	DATE 26 Dec. 17	
	CLASSIFICATION UNRESTRICTED		

High Power Contacts

Mating Level 1 (Note 1)

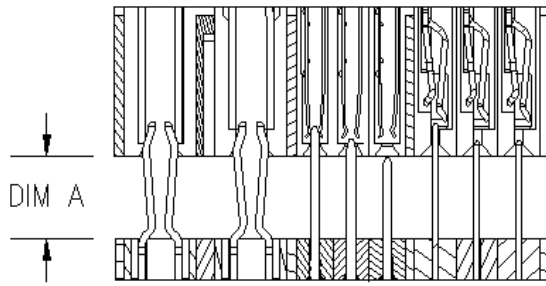

Mating Level 2 (Note 2)

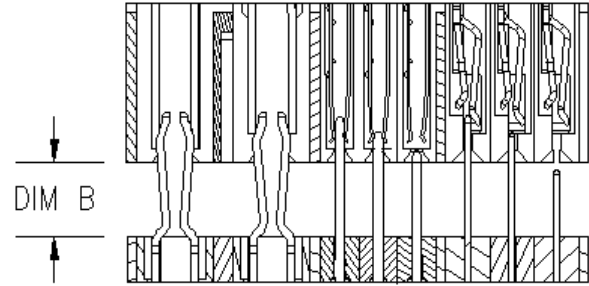

Low Power Contacts and Signal Contacts

Mating Level 2 (Note 2)

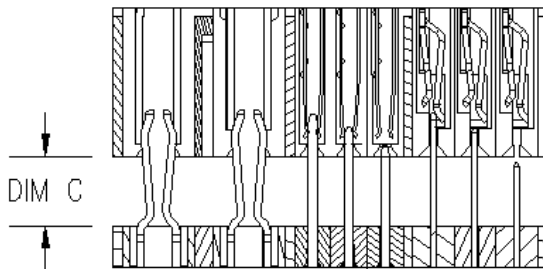

Mating Level 3 (Note 3)

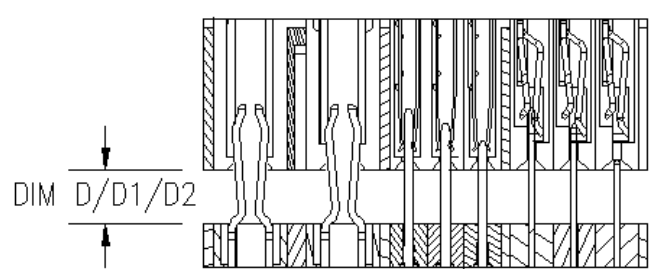

Low Power Contacts

Mating Level 4

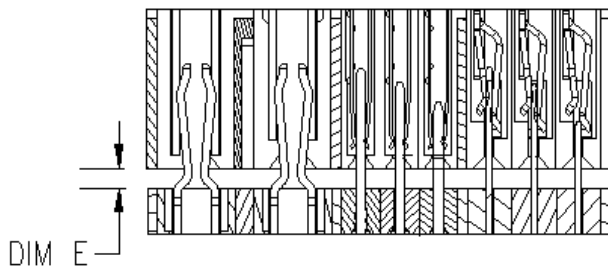

Signal Contacts

Mating Level 5 (Note 1)

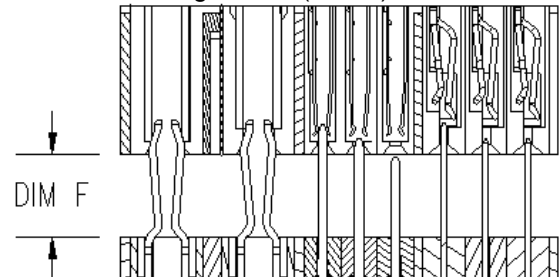

Note 1: The offset distance between “A” and “F” is not enough to consider these as separate levels.

Note 2: The offset distance between “B” and “C” is not enough to consider these as separate levels.

Note 3: For this level, signal contact has 2 options, D1 “MLBF” is normal, and D2 “MLBF2” is customized special application.

Figure 15

	TYPE APPLICATION SPECIFICATION	NUMBER GS-20-141	
	TITLE Application Guide for Pwrblade+™ Press Fit and Solder Tail Plugs and Receptacles	PAGE 18 of 24	REVISION C
	AUTHORIZED BY RAINBOW ZHAN	DATE 26 Dec. 17	
	CLASSIFICATION UNRESTRICTED		

6.9.6 Misalignment

When mating connectors, side-to-side and up-and-down misalignment is allowed to the dimensions given in Figure 16. There is no misalignment for connectors with latch receivers.

(Connectors with guides should be used in applications requiring blind mating. Connectors with latch receivers and connectors without guides should not be used in applications requiring blind mating.)

Misalignment for Connectors With Guides

The connectors can be misaligned nominally by $\pm 1.91\text{mm}$ [$\pm 0.075''$] in the X and Y direction.

Side-to-Side

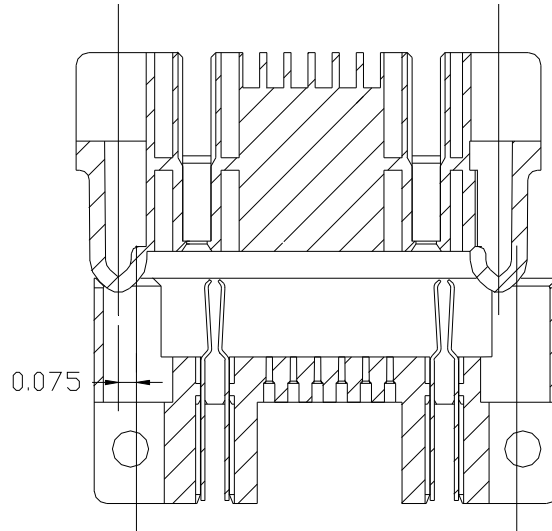

Up-and-Down

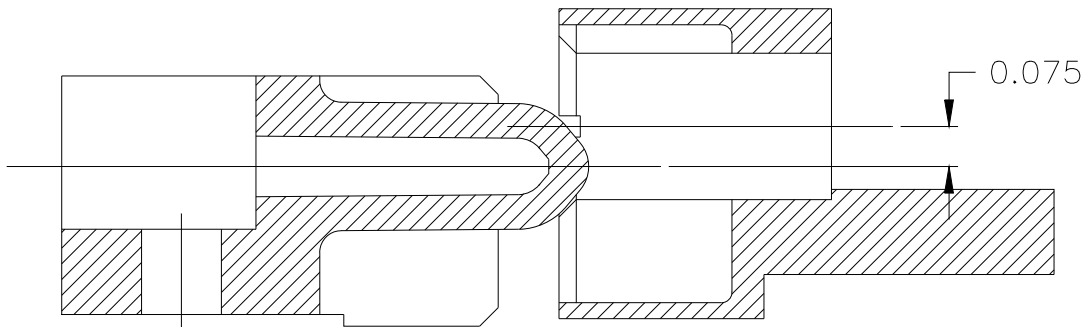

	TYPE APPLICATION SPECIFICATION	NUMBER GS-20-141	
	TITLE Application Guide for Pwrblade+™ Press Fit and Solder Tail Plugs and Receptacles	PAGE 19 of 24	REVISION C
		AUTHORIZED BY RAINBOW ZHAN	DATE 26 Dec. 17
		CLASSIFICATION UNRESTRICTED	

Misalignment for Connectors Without Guides

The connectors can be misaligned nominally by +/-0.25mm [+/-0.010"] in the x direction.
 The connectors can be misaligned nominally by +/-0.56mm [+/-0.022"] in the y direction.

Side-to-Side

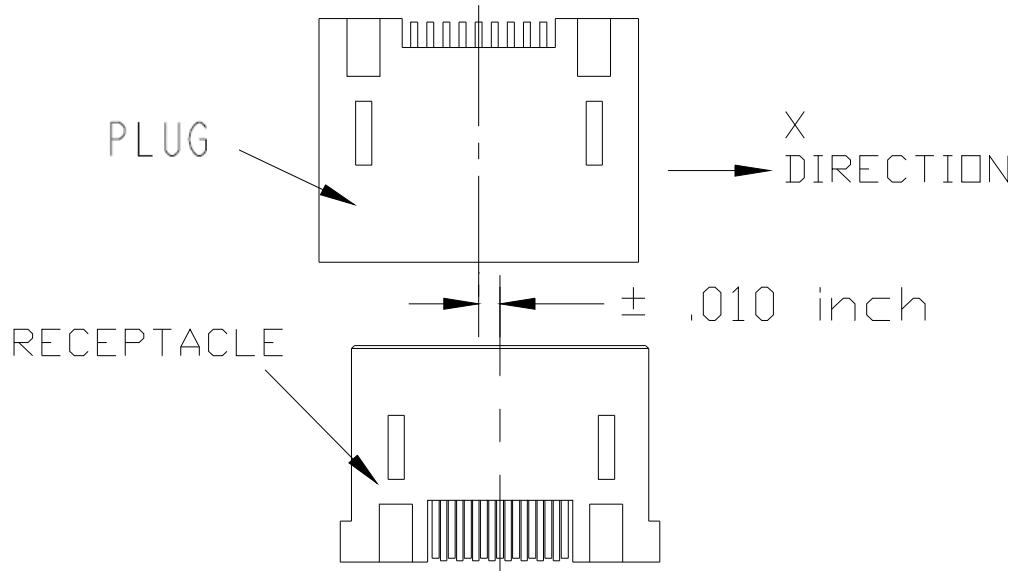

Up-and Down

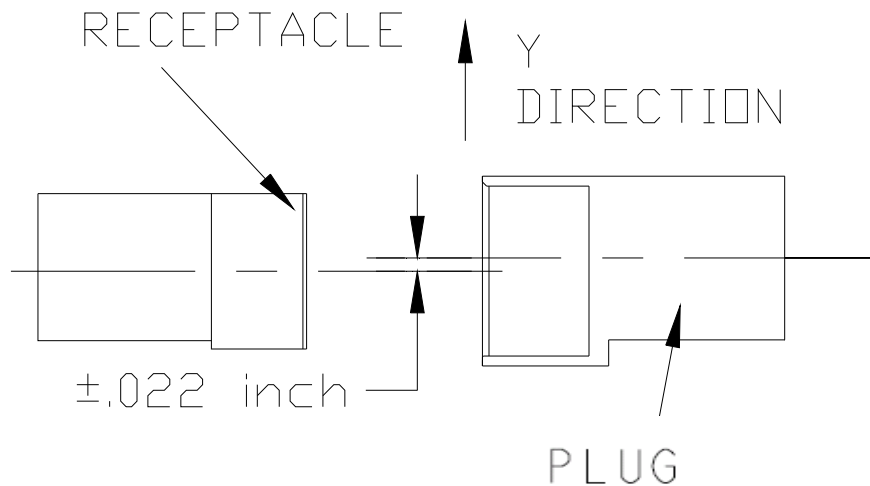

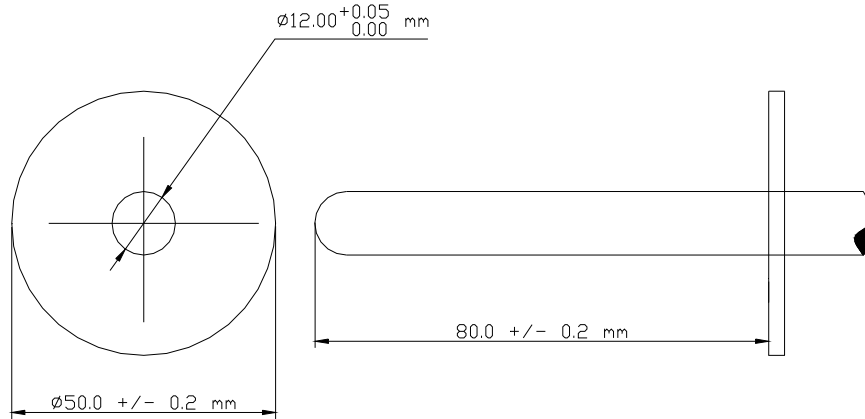

Figure 16

	TYPE	APPLICATION SPECIFICATION		NUMBER	GS-20-141			
	TITLE	Application Guide for Pwrblade+™ Press Fit and Solder Tail Plugs and Receptacles			PAGE	20 of 24	REVISION	C
				AUTHORIZED BY	RAINBOW ZHAN		DATE	26 Dec. 17
				CLASSIFICATION	UNRESTRICTED			

6.10 Circuit Testing

Unmated receptacles and mated plugs must be tested against hazardous voltages using the test probe specified in UL 1950. Specific area of the connector must be tested as indicated in Figure 17.



Dimensions of UL Probe

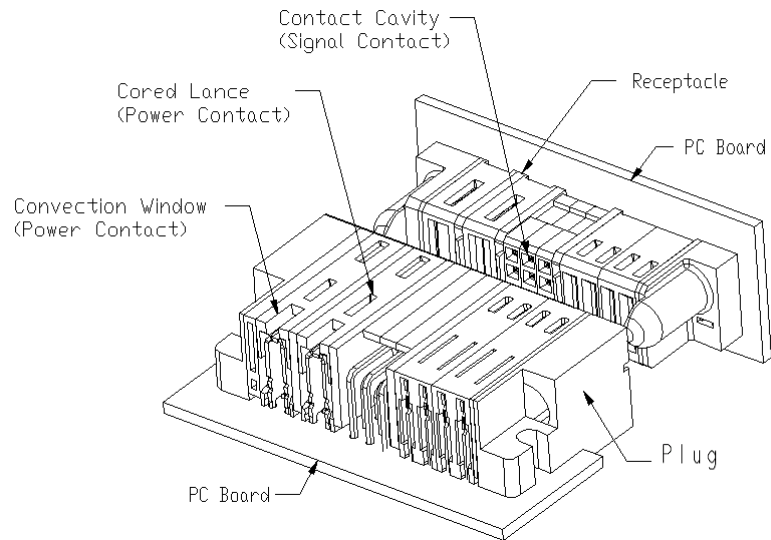

CONNECTOR	AREA TO BE TESTED		
	Unmated Receptacle Contact Cavities	Mated Plug	
		Convection Windows	Cored Lance
Vertical Receptacle	Yes	Yes	Yes
Right Angle Receptacle	Yes	N/A	Yes
Vertical Plug	N/A	Yes	Yes
Right Angle Plug	N/A	N/A	Yes

Figure 17

	TYPE	APPLICATION SPECIFICATION		NUMBER	GS-20-141
	TITLE			PAGE	REVISION
Application Guide for Pwrblade+™ Press Fit and Solder Tail Plugs and Receptacles			21 of 24	C	
			AUTHORIZED BY	DATE	
			RAINBOW ZHAN	26 Dec. 17	
			CLASSIFICATION		
			UNRESTRICTED		

6.11 Connector Unmating

The minimum amount of unmating force per contact is given in Figure 18.

CONTACT	MINIMUM MUMATING FORCE PER CONTACT
High Power	2.2N [8 ounce]
Low Power	0.5N [1.8 ounce]
Signal	0.2N [0.64 ounce]

Figure 18

6.12 Connector Removal

6.12.1 Solder Type Contacts

Connectors with solder type contacts must be removed from the pc board by standard de-soldering methods. After removal from the board, the connector **MUST NOT** be re-used.

6.12.2 Press-Fit Contacts

Connectors with press-fit contacts must be removed from the pc board using a push bar (or flat rock) and pc board support.

(For repairability, the tips of the contacts must extend below the surface of the pc board by at least 1.02 [.040]; If not, the connector **MUST NOT** be removed from the pc board.)

6.12.3 Retention Force

The force retaining the connector with press-fit contacts or retention clips on the pc board can be calculated by:

Retention Force N [lb] =

Number of connector press-fit contacts X minimum retention force per contact

Retention Force N [lb] =

Number of connector retention clips X minimum retention force per retention clip

The minimum amount of retention force per press-fit contact and retention clip is given in Figure 19.

MINIMUM RETENTION FORCE (N [lb.])			
PER PRESS-FIT HIGH POWER CONTACT	PER PRESS-FIT LOW POWER CONTACT	PER PRESS-FIT SIGNAL CONTACT	PER RETENTION CLIP
53.6 [12]	26.8 [6]	6.7 [1.5]	13.3 [3]

Figure 19

6.13 Repair

These connectors are not repairable. Damaged or defective connectors must not be used.

7.0 TOOLING

	TYPE APPLICATION SPECIFICATION	NUMBER GS-20-141	
	TITLE Application Guide for Pwrblade+™ Press Fit and Solder Tail Plugs and Receptacles	PAGE 22 of 24	REVISION C
	AUTHORIZED BY RAINBOW ZHAN	DATE 26 Dec. 17	
	CLASSIFICATION UNRESTRICTED		

7.1 Connectors with Solder Type Contacts

No tooling is required for placement of the connectors with solder type contacts onto the pc board.

7.2 Vertical Plugs with Press-Fit Contacts

Tooling for seating vertical plugs having press-fit contacts is available. A pc board support and application tooling (such as arbor press) that provides sufficient amount of downward force to insert the contacts into the pc board holes must be used with the seating tool. The seating tooling reference to FCI CAM Tool 430169.

7.3 Receptacle and Right-Angle Plugs with Press-Fit Contacts

7.3.1 Application Tooling

The application tooling (such as an arbor press) used to seat these connectors must provide sufficient amount of downward force to insert the contacts into the pc board holes.

7.3.2 PC Board Support

A pc board support must be used to prevent bowing of the pc board during the placement of these connectors on the board. The board support must have a flat surface with holes or a channel large enough and deep enough to receive any protruding components. The pc board must be secured to the board support to prevent movement of the board during seating. Refer to Figure 20.

The board support must also be used when removing these connectors from the pc board.

7.3.3 Flat Rock Tooling

Commercially available bar stock (flat rock tooling) with a flat surface large enough to cover all contacts and any protruding components must be used with the application tooling to seat these connectors. For vertical receptacle with guides, the flat rock tooling must be sized to fit between the guides.

For removing these connectors from the pc board, it is suggested that the pc board be supported from the connector side and that the connector be removed using flat rock tooling.

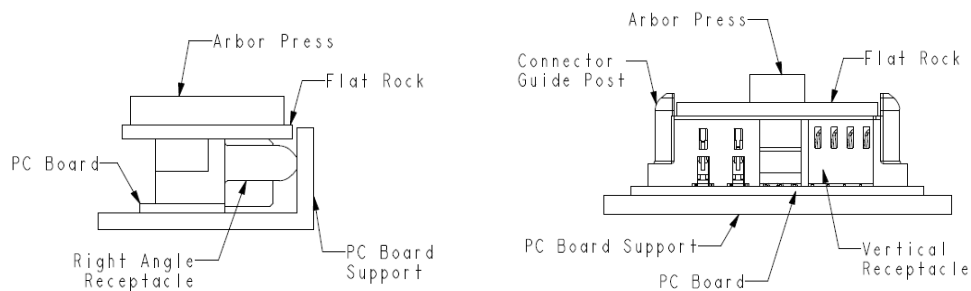

Seating Receptacles and Right-Angle Plugs with Press-Fit Contacts
Figure 20

	TYPE	APPLICATION SPECIFICATION		NUMBER	GS-20-141	
	TITLE			PAGE	REVISION	
Application Guide for Pwrblade+™ Press Fit and Solder Tail Plugs and Receptacles			23 of 24		C	
			AUTHORIZED BY		DATE	
			RAINBOW ZHAN		26 Dec. 17	
			CLASSIFICATION			
			UNRESTRICTED			

8.0 PRODUCT PART NUMBER ASSIGNMENTS

8.1 Base Number: **10106 AAA**

AAA definition

AAA	High Power Contact Pitch	Right Angle/ Vertical	Plug / Receptacle	Solder to Board/ Press Fit
116	7.62 mm	Right Angle	Plug	Solder To Board
117				Press Fit
118			Receptacle	Solder To Board
119				Press Fit
120		Vertical	Plug	Solder To Board
121				Press Fit
122			Receptacle	Solder To Board
123				Press Fit
124	6.35 mm	Right Angle	Plug	Solder To Board
125				Press Fit
126			Receptacle	Solder To Board
127				Press Fit
128		Vertical	Plug	Solder To Board
129				Press Fit
130			Receptacle	Solder To Board
131				Press Fit
132	5.08 mm	Right Angle	Plug	Solder To Board
133				Press Fit
134			Receptacle	Solder To Board
135				Press Fit
136		Vertical	Plug	Solder To Board
137				Press Fit
138			Receptacle	Solder To Board
139				Press Fit
262	Hybrid design or other customized pitch	Right Angle	Plug	Solder To Board
263				Press Fit
264			Receptacle	Solder To Board
265				Press Fit
266		Vertical	Plug	Solder To Board
267				Press Fit
268			Receptacle	Solder To Board
269				Press Fit

Figure 21

REVISION RECORD

	TYPE	APPLICATION SPECIFICATION		NUMBER	GS-20-141	
	TITLE			PAGE	REVISION	
Application Guide for Pwrblade+™ Press Fit and Solder Tail Plugs and Receptacles			24 of 24		C	
			AUTHORIZED BY		DATE	
			RAINBOW ZHAN		26 Dec. 17	
			CLASSIFICATION			
			UNRESTRICTED			

REV	PAGE	DESCRIPTION	ECR#	DATE
A	All	New Release	-	12/22/2011
B	All	Change name description from "header" to "plug".	ELX-DG-20876	05/13/2015
C	7,15,16	Add the PCB layout description and MLBF2 for signal contact	ELX-DG-22779	12/26/2017