

Amphenol	Product Application Specification For Orthogonal MINI Cool edge Connector Small Press-fit	Product Spec. # S-ME-008		Date : 02/28/2020
		Rev. A	ECN # CD1996	Page : 1 of 12

**Product Application Specification
For MINI Orthogonal Cool edge Connector
Small Press-fit**

REVISION RECORD

<u>REV</u>	<u>PAGE</u>	<u>DESCRIPTION</u>	<u>ECN#</u>	<u>DATE</u>	<u>Prepare By</u>
A	All	First Release	CD1996	2020-02-28	Xg.liu

Prepared by : _____	Date: _____	Approved by : _____	Date: _____
(Product Engineer)		(Engineering Manager)	

Amphenol	Product Application Specification For Orthogonal MINI Cool edge Connector Small Press-fit	Product Spec. # S-ME-008		Date : 02/28/2020
		Rev. A	ECN # CD1996	Page : 2 of 12

TABLE OF CONTENT:

1. OBJECTIVE..... 3

2. SCOPE 3

3. DRAWING AND APPLICABLE DOCUMENTS 3

4. PC BOARD REQUIREMENTS..... 4

4.1. MATERIAL AND THICKNESS 4

4.2. HOLE DIMENSIONS 4

4.3. PCB LAYOUT..... 4

4.4. WIPE LENGTH..... 5

4.5. SUPPORT PRESS-FIT TIMES 5

4.6. BACK DRILLING 5

5. APPLICATION TOOLING 6

6. APPLICATION PROCEDURE 9

7. POST-APPLICATION INSPECTION REQUIREMENTS 11

8. CONNECTOR REMOVAL TOOLING 11

9. REVISION RECORD 12

1. OBJECTIVE

This specification provides information and requirements for customer application of the Orthogonal MINI Cool edge connector Small PF. It is intended to provide general guidance for process development. It should be recognized that no single process will work under all customer applications and the customers should develop processes to meet individual needs. However, if the processes vary from the recommended one, Amphenol cannot guarantee acceptable results.

2. SCOPE

This specification provides information and requirements regarding application of Orthogonal MINI Cool edge connector to printed circuit boards (PCB). The connectors are designed for mother/daughter board applications and will accept different thickness of daughter card.

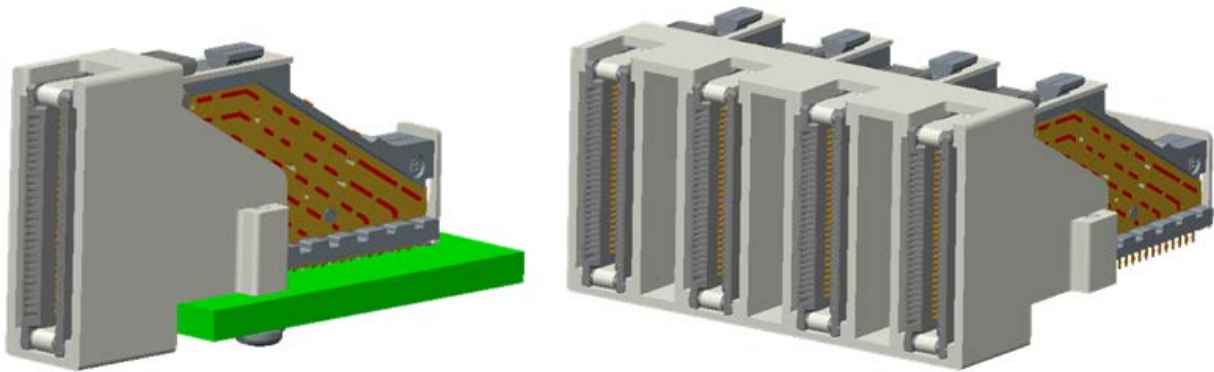

Figure 1: Orthogonal MINI Cool edge connector Small PF

3. DRAWING AND APPLICABLE DOCUMENTS

- Amphenol Product Specification S-ME-001
- Amphenol Customer Drawings

Amphenol product drawings and specifications are available by accessing the Amphenol website or contacting the Amphenol Technical Service. In the event of a conflict between this specification and the product drawing, the drawing takes precedence. Customers should refer to the latest revision of Amphenol product drawings for appropriate product details.

4. PC BOARD REQUIREMENTS

4.1 MATERIAL AND THICKNESS

The pc board material should be glass epoxy (FR4 or G-10) or more advance material. The recommended minimum pc board(mother board) thickness be 1.20mm

4.2 Press-fit HOLE DIMENSIONS

The holes must be drilled and plated through to dimensions which are defined in customer drawing.

4.3 LAYOUT

The holes for the connector assembly must be precisely located to ensure proper placement and optimum performance of the connector assembly. Recommended general holes, pads, dimensions, and tolerances are provided in Figure 2 . It's a general layout, please refer to customer drawing for recommended PCB layout and related dimensions.

FOR 1.20mm Min thickness PCB

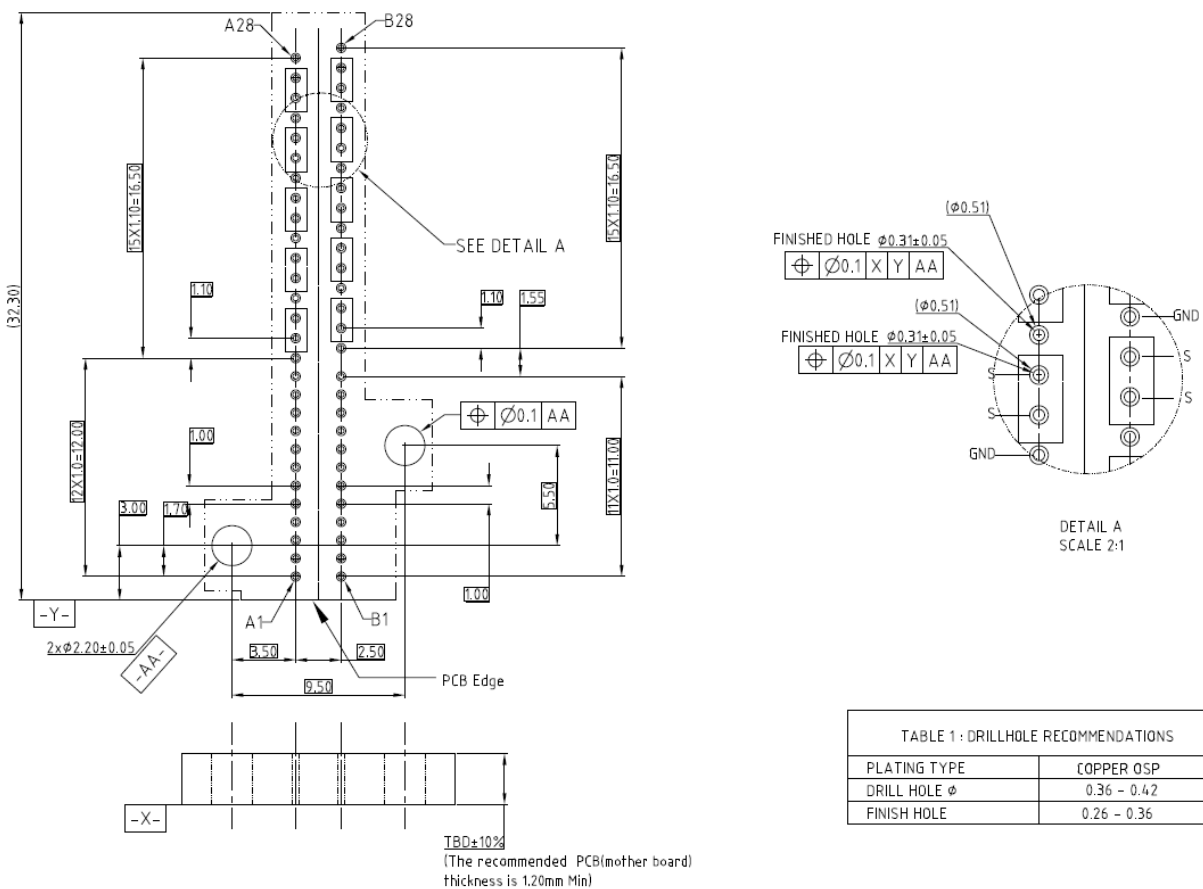

**GENERAL PCB LAYOUT FOR MOTHER BOARD
(YOUR CONFIGURATION MAY VARY)**

FIGURE 2

**DAUGHTER CARD(EDGE CARD)
WITH 56pin Orthogonal MINI Cool edge Connector**

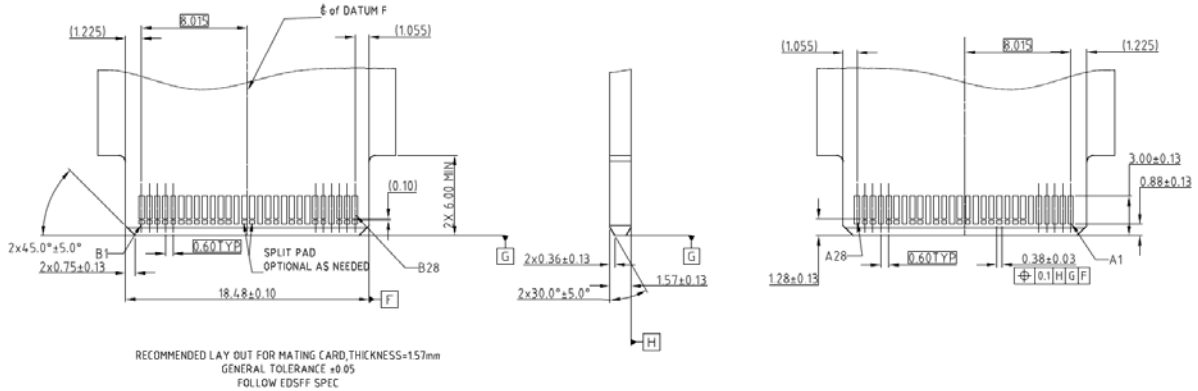

**GENERAL PCB LAYOUT FOR EDGE CARD
(YOUR CONFIGURATION MAY VARY)**

FIGURE 3

4.4 WIPE LENGTH

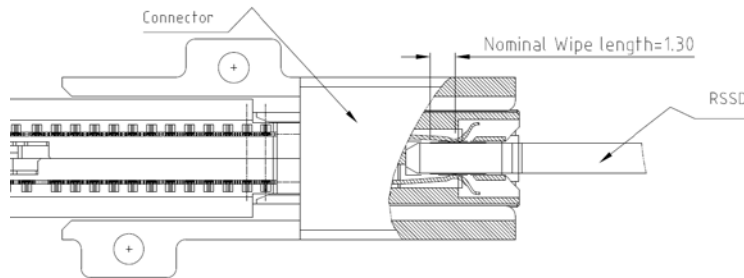

Signal pin Nominal wipe length: 1.30mm; Others pin Nominal wipe length:1.70mm

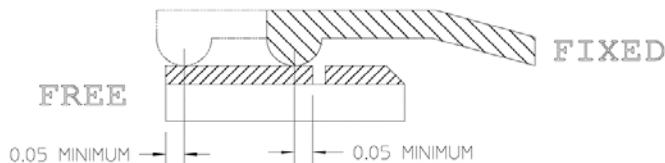

Notes:

In the direction of mating, the Free contact location must be a minimum of 0.05 mm from either end of the Fixed contact mating interface after mating and latching.

4.5 SUPPORT PRESS-FIT TIMES

The PCB finished holes need to be able to withstand pressure three times.

4.6 BACK DRILLING

Back drilling is used by system designers that reduces the length of a conductive Via which will improve high speed signal integrity performance. When back drilling is performed it is important to avoid damaging the portion of the via that makes contact with any press-fit tails. See below for recommendations on proper back drilling.

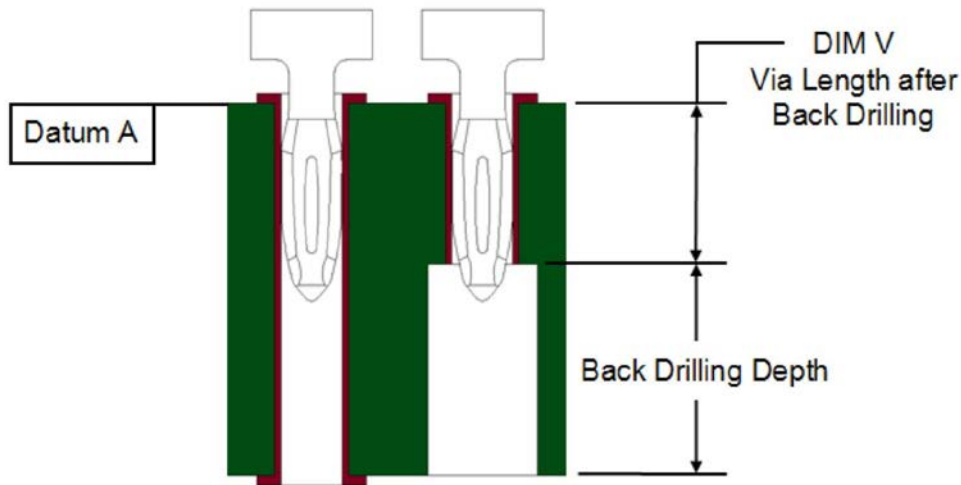

Figure 4: View of Back Drilling

After a back drilling, the remaining via barrel length(Dim V) must be at least 0.90mm to ensure a reliable connection between the press-fit tails and the PCB. Assuming that the PCB manufacturer can maintain a back drilling depth tolerance of $\pm 0.30\text{mm}$ relative to datum A, the nominal via length after back drilling would need to be 1.2mm.

5. APPLICATION TOOLING

56Pin 1x4 Orthogonal MINI Cool edge connector Small PF

The application tools recommended for 56pin 1x4 Orthogonal MINI Cool edge connector Small PF(Pitch 12.5mm)is shown in Figure 5. A special bottom support fixture will be necessary only if the connector tail are longer than the thickness of the PCB (the nominal tail length is 1.20mm).

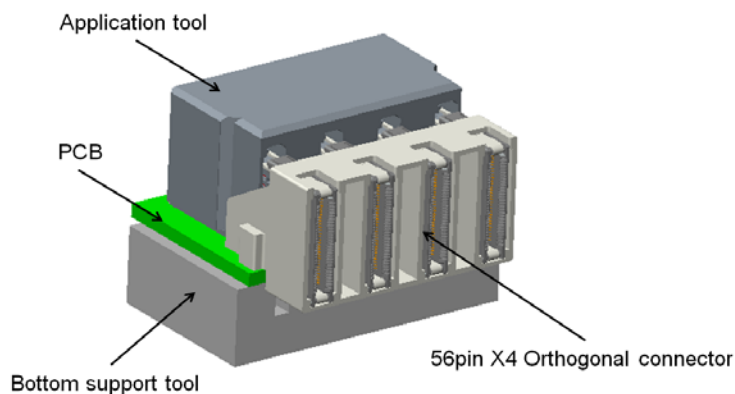

Figure 5: Orthogonal MINI Cool edge connectors x4 application tools

APPLICATION TOOLING

The application tools recommended drawing for 56pin 1x4 Orthogonal MINI cool edge connector (Pitch 12.5mm) are shown in Figure 6.

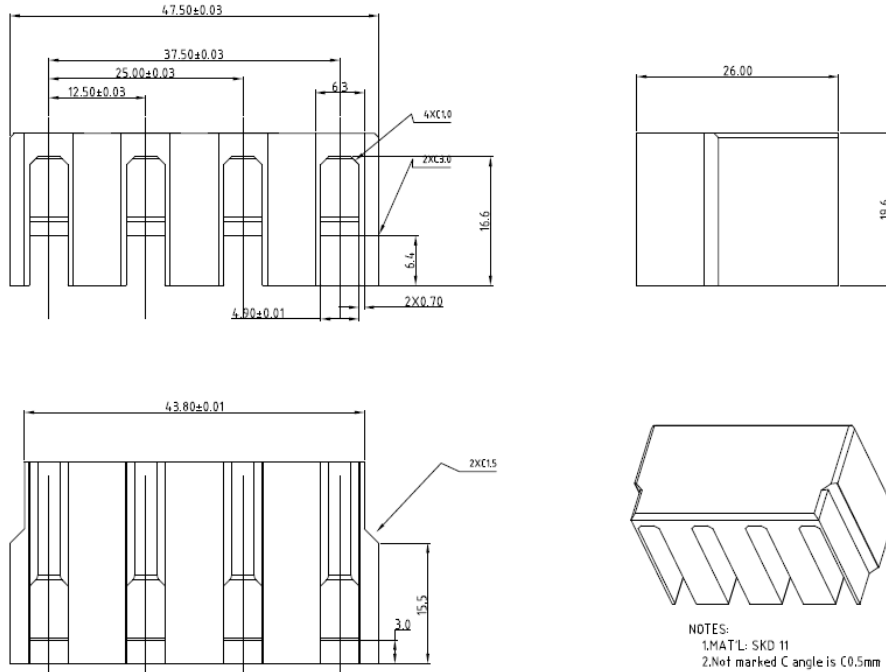

Figure 6: Orthogonal MINI Cool edge connector 1x4 application tools drawing

56Pin 1X1 Orthogonal MINI cool edge connector Small PF

The application tools recommended for 56pin 1X1 Orthogonal MINI cool edge connector Small PF (Pitch 12.5mm) are shown in Figure 7. A special bottom support tool will be necessary only if the connector tail are longer than the thickness of the PCB (the nominal tail length is 1.20mm). This tool could be a PCB with oversized holes or a custom tool designed by the user.

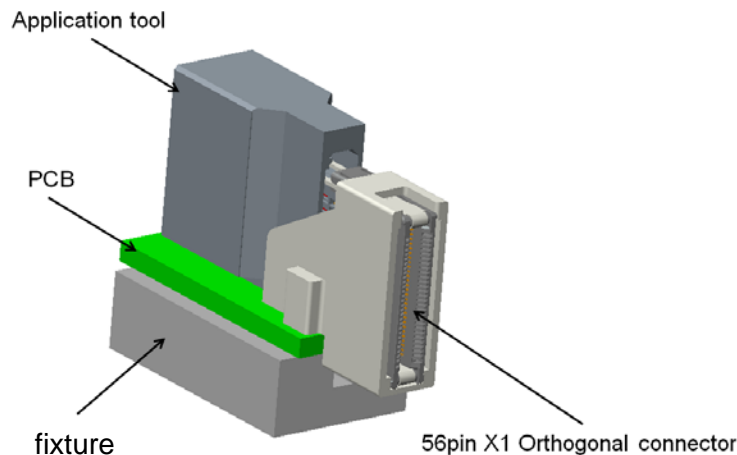

Figure 7: Orthogonal Cool edge MINI connectors 1X1 application tools

CUSTOM TOOLING

The application tools recommended drawing for 56pin 1X1 Orthogonal MINI cool edge connector (Pitch 12.5mm) are shown in Figure 8.

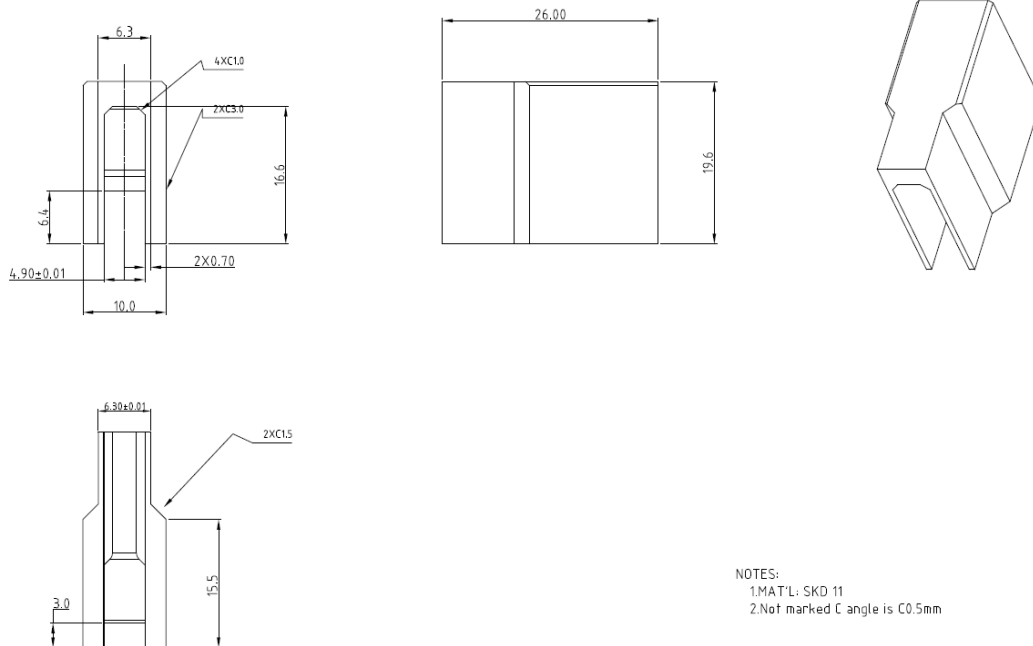

Figure 8: Orthogonal MINI Cool edge connector 1X1 application tools drawing

INSERTION PRESSES Considerations when specifying a press

The specified application tooling can be worked with in a variety of pressing machine. Several important items need to be considered when to consider when selecting an insertion press include:

- The press must have sufficient force to insert the specific receptacle configuration.
- The press arm should be sufficiently long to cover the Press Block tooling. This will prevent tolling fix.
- The fixture at bottom should be large enough to properly accommodate the PCB size.

Typical press types include:

- Manual arbor press
- Pneumatic press
- Hydraulic press
- Servo driven electronic press (IMPRESS)

The preferred press type is the servo driven electronic press. This press gives the best control during the insertion process and offers flexibility. Amphenol offers arbor, pneumatic and electronic presses. For more information, contact your local Customer Service Representative.

6. APPLICATION PROCEDURE

56Pin 1x4 Orthogonal MINI cool edge connector small PF

The application procedure for the 56pin 1x4 Orthogonal is as follows.

- Place Connector in the specific location on the PCB that all press-fit tails line up with the proper holes.

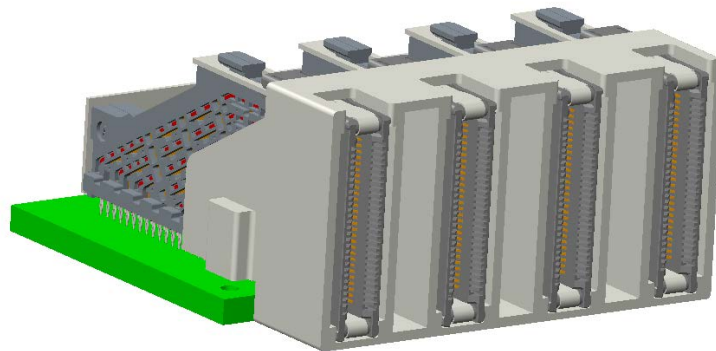

- Place the application tool in the proper location with respect to the Connector as shown below.

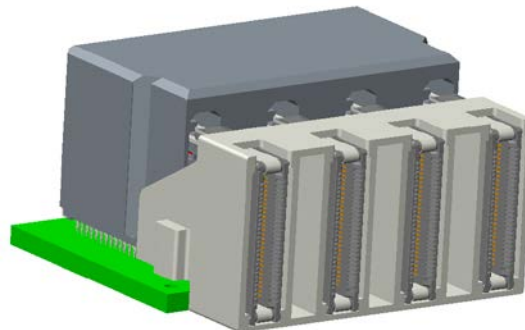

- Press fit: To ensure proper insertion, connectors must be centered beneath the press ram.
- Remove application tool and Install the M2 screw.

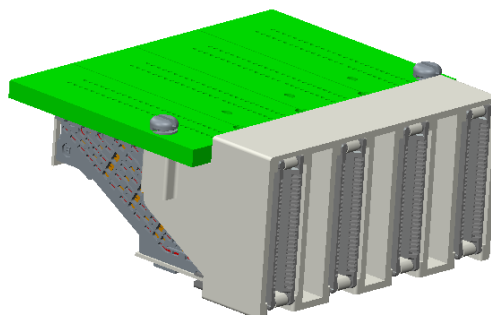

RECOMMENDED INSERTION FORCES

The recommended maximum insertion force for each press-fit pin is 28 N.

These recommended maximum force recommendations have been determined to yield acceptable insertion results for SnPb PTH's. While it is acceptable to use a lower force per press-fit pin, steps should be taken to guarantee that the connector is fully seated. Force settings may vary with different types of PTH finishes. Customers should develop parameters that best suit individual application requirements.

EXAMPLE: For 56Pin 1x4 Orthogonal cool edge connector, there are 224 press-fit tails being inserted into the PC board. Therefore, the maximum recommended press setting would be 6272 N (224 press-fit tails x 28 N).

- Actuate the insertion press

Actuation of the insertion press should be slow and controlled (example: 25.4mm/minute), not fast like a punch press. Inserting to a specified force will yield more consistent results than inserting to a set distance.

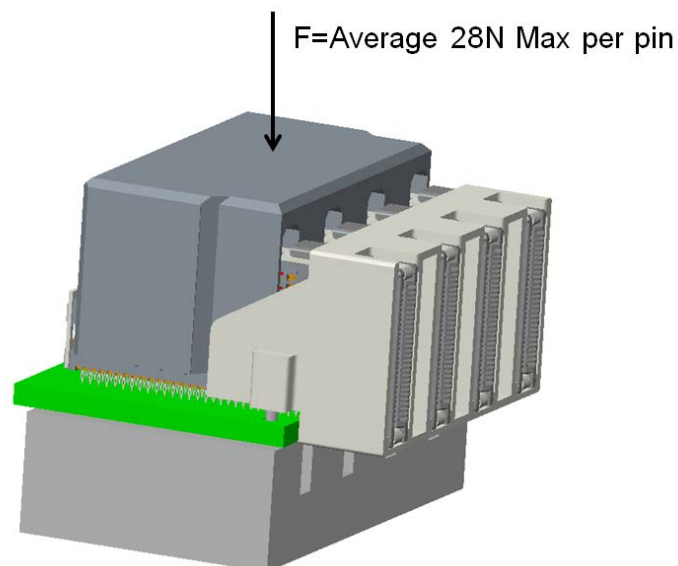

- Remove assembly from insertion press.
- Inspect product for proper application.

7. POST-APPLICATION INSPECTION REQUIREMENTS

Post-application inspection should consist of several simple checks to assure that the Connector is applied properly and is not damaged.

- Visually assure that all press-fit tails are seated in the proper PCB holes and that none have been crushed during application.
- Visually assure that the plastic standoffs on the bottom of each assembly are seated within 0.10 mm of flush to the PCB but not crushed (see Figure 8). A larger gap beneath the standoffs may indicate that the connector is not seated fully or is not seated parallel to the board. This can cause misalignment when the PCB is mated to the SSD card.

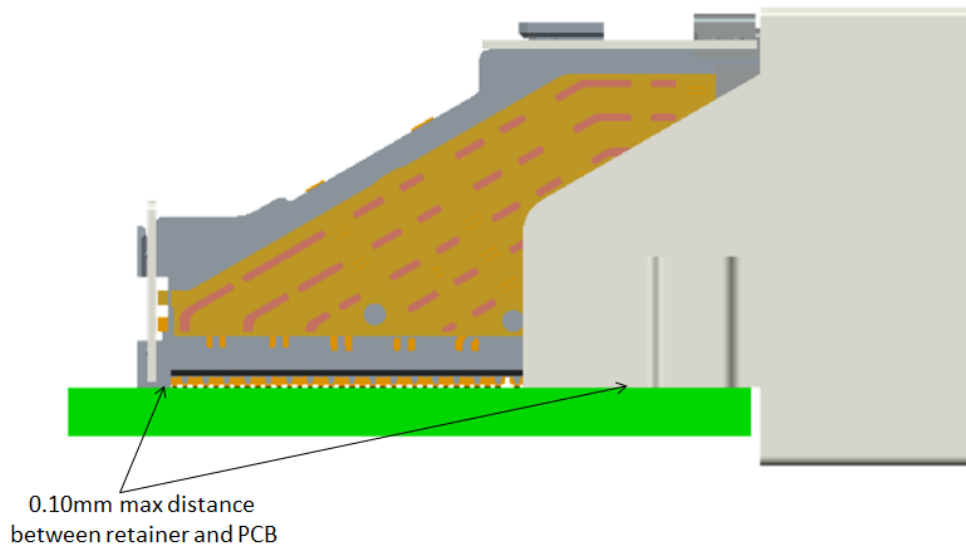

Figure 9: Proper seating depth

8. CONNECTOR REMOVAL TOOLING

The following are Amphenol removal tool part numbers for Orthogonal Cool edge connectors. The referenced Amphenol Manual describes proper connector removal procedures for each type of connector.

Connector PN	Column pitch, mm	Removal tool part no	Manual no.
ME20056231101X		ME20056RM01	R-ME-056
ME30056231101X			
ME20056231104X	12.5	ME20056RM02	
ME30056231104X			

For some connector configurations it may be possible to use multiple repair methods. All recommended methods for repair will be described in the Amphenol manuals listed above.

