

**Product Application Specification
Slim Cool Edge, 0.65mm pitch, Vertical
Connector, Gen6**

**PN:
SE32XXXXXXXXXX**



REVISION RECORD

<u>REV</u>	<u>PAGE</u>	<u>DESCRIPTION</u>	<u>ECN#</u>	<u>DATE</u>	<u>Prepare By</u>
A	8	FIRST RELEASE	XXXX	2024.12.18	Nick.yang

Prepared by :

Date:

Approved by :

Date:

(Product Engineer)

(Engineering Manager)

TABLE OF CONTENT:

1. OBJECTIVE	3
2. SCOPE	3
3. DRAWING AND APPLICABLE DOCUMENTS.....	3
4. PC BOARD REQUIREMENTS	3
4.1.MATERIAL AND THICKNESS.....	3
4.2.TOLERANCE	3
4.3.PCB LAYOUT	3
5. MATING AND ALIGNMENT	6
5.1.GATHERABILITY IN "X" DIRECTION	6
5.2.GATHERABILITY IN "Y" DIRECTION.....	6
5.3.TILT AND SKEW	6
6. RECOMMENDED REWORK PROCESS AND REFLOW PROFILE	7
7. CURRENT RATING PER SIGNAL PIN AND POWER PIN	8
8. PIN MAP.....	8

1. OBJECTIVE

This specification provides information and requirements for customer application of the 0.65pitch Gen6 vertical Slim Cool edge connector. It is intended to provide general guidance for process development. It should be recognized that no single process will work under all customer applications and the customers should develop processes to meet individual needs. However, if the processes vary from the recommended one, Amphenol cannot guarantee acceptable results.

2. SCOPE

This specification provides information and requirements regarding application of 0.65 pitch vertical Slim Cool edge connector to printed circuit boards (PCB). The connectors are designed for mother/daughter board applications and will accept different thickness of daughter card. They are available with multiple contacts.

3. DRAWING AND APPLICABLE DOCUMENTS

- Amphenol Product Specification S-SE-022
- Application Amphenol Customer Drawings

Amphenol product drawings and specifications are available by accessing the Amphenol website or contacting the Amphenol Technical Service. In the event of a conflict between this specification and the product drawing, the drawing takes precedence. Customers should refer to the latest revision level of Amphenol product drawings for appropriate product details.

4. PC BOARD REQUIREMENTS

4.1 MATERIAL AND THICKNESS

The pc board material shall be glass epoxy (FR4 or G-10).

4.2 MOTHER BOARD COPLANARITY TOLERANCE

Maximum allowable bow (co-planarity) shall be 0.03mm across the length of the pad area in the case of 0.13mm thick solder paste



FIGURE 1

4.3 LAYOUT

The holes for the connector assembly must be precisely located to ensure proper placement and optimum performance of the connector assembly. Recommended general holes, pads, dimensions, and tolerances are provided in Figure 2 to 5. It's a general layout, please refer to appropriate sales drawing for recommended PCB layout and thickness for each parts.

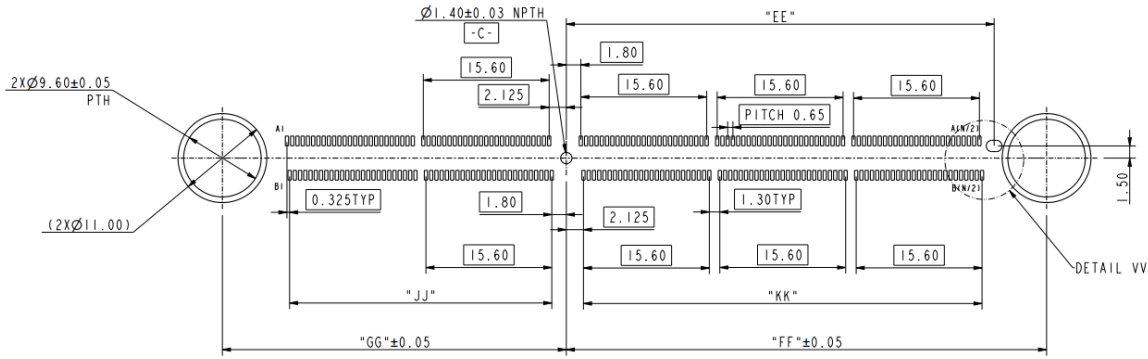

RECOMMEND SOLDERING PCB LAYOUT
 GENERAL TOLERANCE ±0.05

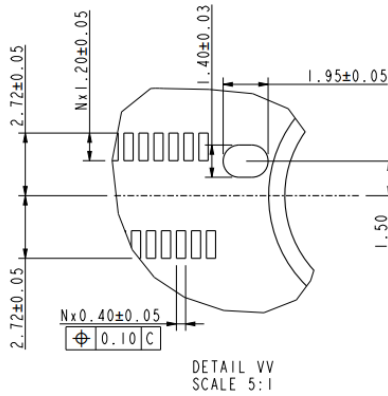

PIN COUNT	DIMENSION (mm)				
	N	EE	GG	FF	JJ
100	19.225	25.725	25.725	15.60	15.60
	36.125	25.725	42.625	15.60	32.50
150	19.225	42.625	25.725	32.50	15.60
	53.025	25.725	59.525	15.60	49.40
200	36.125	42.625	42.625	32.50	32.50
	19.225	59.525	25.725	49.40	15.60
250	53.025	42.625	59.525	32.50	49.40
	36.125	59.525	42.625	49.40	32.50
	69.925	25.725	76.425	15.60	66.30
	19.225	76.425	25.725	66.30	15.60

GENERAL PCB LAYOUT FOR MOTHER BOARD
FOR 100pin/150pin/200pin/250pin
FIGURE 2

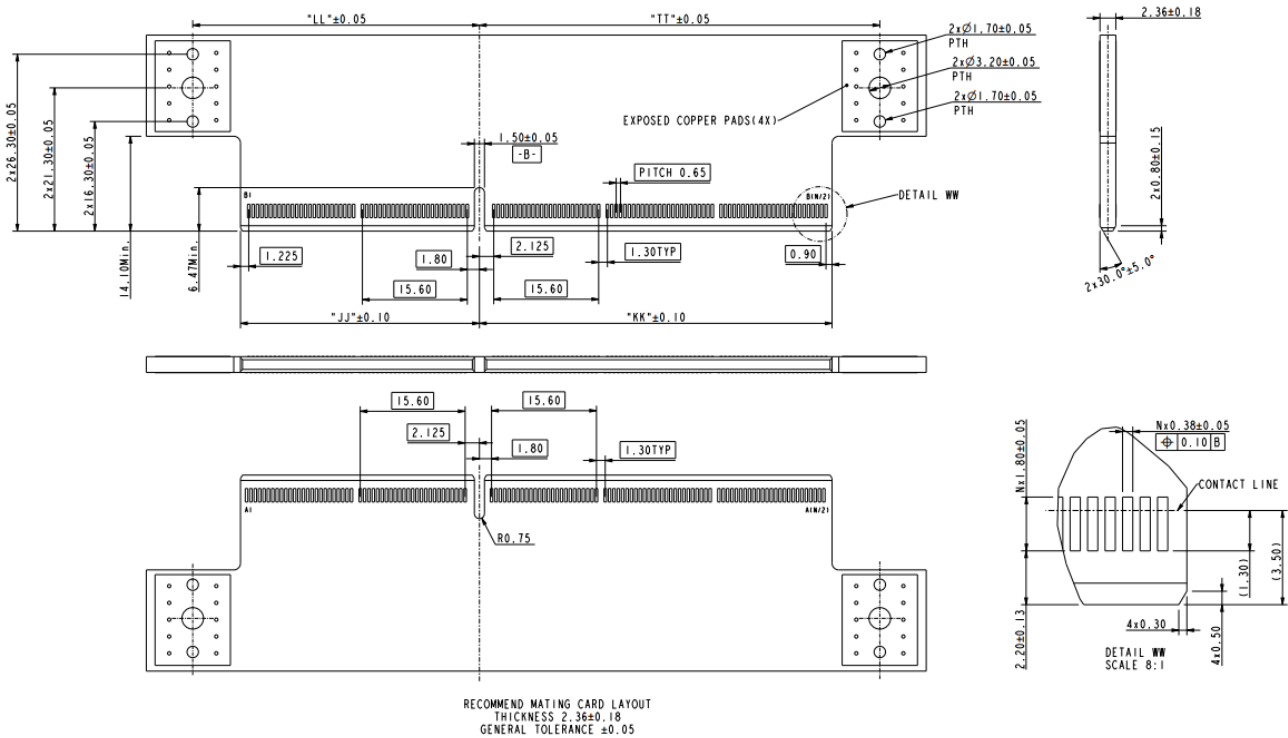

RECOMMEND MATING CARD LAYOUT
 THICKNESS 2.36±0.18
 GENERAL TOLERANCE ±0.05

PIN COUNT	DIMENSION (mm)			
	N	JJ	KK	LL
100	16.825	16.50	25.725	25.725
150	16.825	33.40	25.725	42.625
	33.725	16.50	42.625	25.725
200	16.825	50.30	25.725	59.525
	33.725	33.40	42.625	42.625
	50.625	16.50	59.525	25.725
250	33.725	50.30	42.625	59.525
	50.625	33.40	59.525	42.625
	16.825	67.20	25.725	76.425
	67.525	16.50	76.425	25.725

GENERAL PCB LAYOUT FOR MATING CARD
FOR 100pin/150pin/200pin/250pin
FIGURE 3

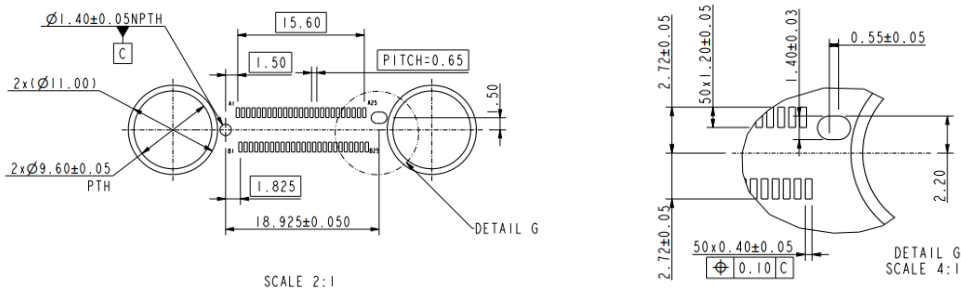

RECOMMEND SOLDERING PCB LAYOUT
 GENERAL TOLERANCE ±0.05

GENERAL PCB LAYOUT FOR MOTHER BOARD
FOR 50pin
FIGURE 4

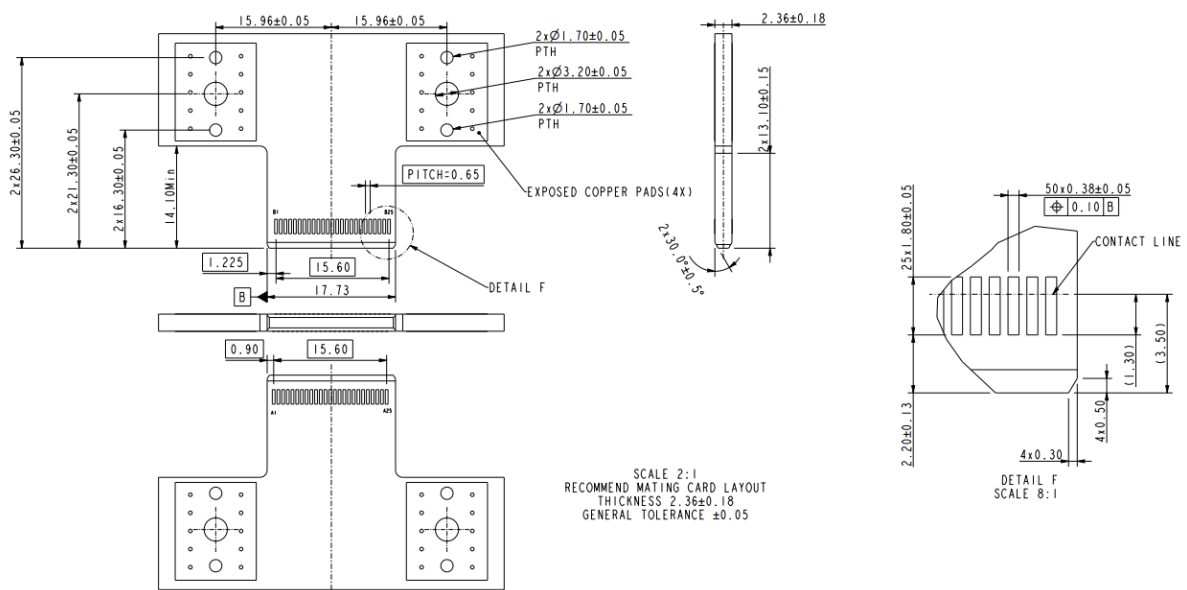

SCALE 2:1
 RECOMMEND MATING CARD LAYOUT
 THICKNESS 2.36±0.18
 GENERAL TOLERANCE ±0.05

GENERAL PCB LAYOUT FOR MATING CARD
FOR 50pin
FIGURE 5

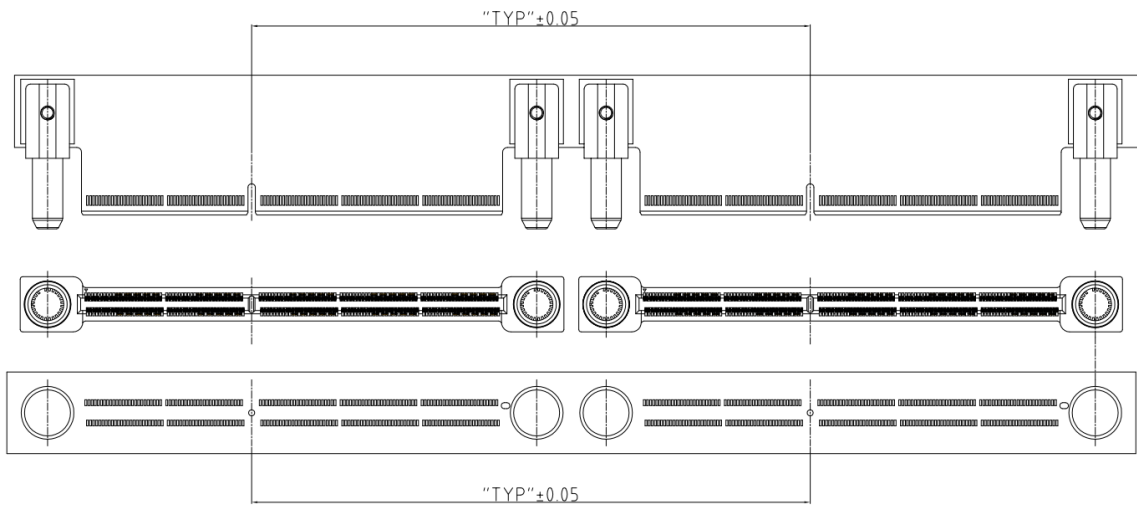

GENERAL LAYOUT TOLERANCE FOR BRIDGE CONNECTION APPLICATION
(YOUR CONFIGURATION MAY VARY)
FIGURE 6

5. MATING AND ALIGNMENT

5.1 GATHERABILITY IN "X" DIRECTION

Nominal misalignment correction in "X" DIRECTION: +/-1.55mm

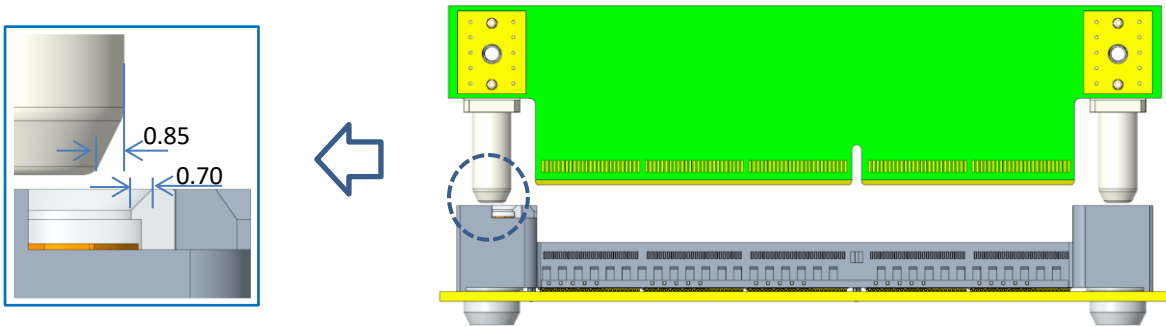

FIGURE 5

5.2 GATHERABILITY IN "Y" DIRECTION

Nominal misalignment correction in "Y" DIRECTION: +/-1.55mm

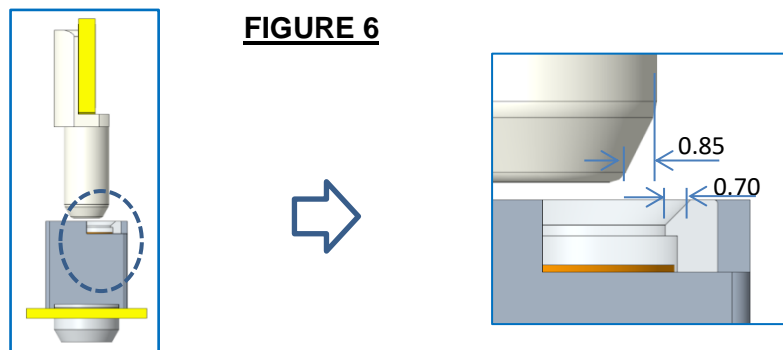

FIGURE 6

5.3 TILT AND SKEW

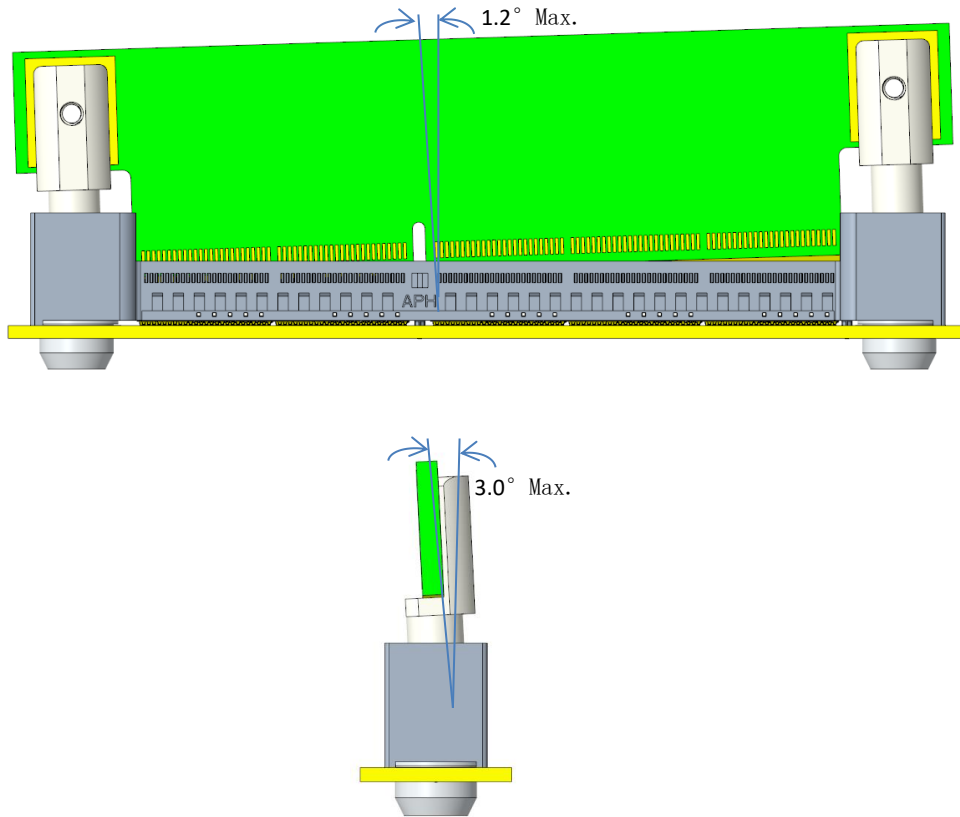

FIGURE 8

Notes:

This is a generic calculation based on Amphenol Cool edge tolerances and may be impacted by the PCB manufactures capabilities.

6. RECOMMENDED REWORK PROCESS AND REFLOW PROFILE

It can be reworked well under BGA rework station, and it needs to re-design and make mini-stencil to print those TH pins together with SMT pads, it also needs to add a shield wall, it can avoid socket's housing material melting or bubble defect.

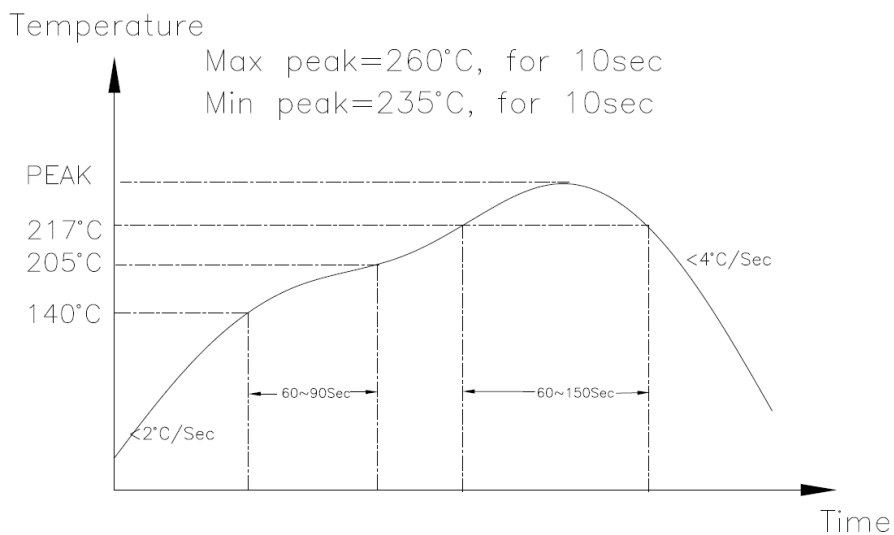

REFLOW PROFILE FOR LEAD FREE

7. CURRENT RATING PER SIGNAL PIN AND POWER PIN

Please refer to below table for signal pin current rating

PIN COUNT	CURRENT (A)
≤ 10pin	1.0
≤ 20pin	0.8
≤ 60pin	0.6
> 60pin	0.5

Power pin current rating is 50 to 100A, Need to do customized design according to customer needs.

8. PIN MAP

The pin map definition must conform to "GSSGSSGSSG.....GSSG".

The pin map and part number can be different upon different signal requirement.

Please confirm the definition of pin map with Amphenol.