

TB-2344

XCede® HD2 Connector Design Guidelines

Revision “A”

Specification Revision Status

Revision	SCR No.	Description	Initial	Date
“A”	S7752	Initial Release	Boris.W	06/18/2019

Amphenol TCS

A Division of Amphenol Corporation

Amphenol TCS
200 Innovative Way, Suite 201
Nashua, NH 03062
603.879.3000

www.amphenol-icc.com

Aptera, Chameleon, Crossbow, eHSD, GbX, HD Plus, HDM Plus, HDM, HD-Optyx, InfinX, Lynx, NeXLev, Paladin, Ventura, VHDM, VHDM-HSD, and XCede, are trademarks or registered trademarks of Amphenol Corporation. AirMax VS is a registered trademark of FCI. Information contained in this document is summary in nature and subject to change without notice. Appearance of the final, delivered product may vary from the photographs shown herein.

1.0 Introduction

1.1. This document describes design rules for Amphenol's XCede HD2 (hereinafter (XHD2) connector system. This document is intended to serve as an application guide for designing XHD2 into various customer system configurations. Contact Amphenol TCS (hereinafter ATCS) Field Applications Engineering (hereinafter FAE) for product availability information.

1.2. Reference Documents

TB-2343 XCede HD2 General Product Specifications

TB-2237 XCede HD Family Routing Guidelines

TB-2252 XCede HD Family Backplane Connector Installation

TB-2244 XCede HD Family Daughtercard Connector Installation

TB-2253 XCede HD Family Daughtercard Removal and Reinsertion Process

TB-2245 XCede HD Family Backplane Removal and Reinsertion Process

1.3. Document Confidentiality

This document is company confidential and may be used only by customers for their internal use. This document contains proprietary information, which is not to be used in any way not previously approved by ATCS.

1.4. General Product Description

1.4.1. The standard XHD2 differential interconnect platform consists of connectors featuring 3, 4, or 6 differential pairs, with an optional extra ground lead available on the A wafer. 2 Pair and 8 Pair versions of XHD2 may be tooled in future. The interconnect system features solder-less eye-of-the-needle press-fit terminations only available with Pb-free plating to the printed circuit board and high temperature (260°C) SMT compatible plastic material. XHD2 incorporates a unique 3-D resonance damping shield that enables low crosstalk across a wide frequency spectrum. An orthogonal interconnect system may be developed for use in a "mid-plane" configuration where daughtercards (hereinafter DC) plug into the backplane (hereinafter BP) from both sides. The XHD2 interconnect platform may also tool right angle male (hereinafter RAM) and/or inverted right angle male (hereinafter IRAM) versions in future.

1.4.2. DC connector building blocks include signal modules, power modules, guidance/polarizing modules and grounded guidance modules, all of which are assembled to a metal mechanical organizer, sometimes called a stiffener. Contact ATCS FAE for product availability information.

1.4.3. BP connectors are typically arranged in 4, 6 and 8 column signal modules. These are sometimes referred to as 4, 6, and 8 'position' modules. Contact ATCS FAE regarding requests for non-standard column lengths.

2.0 Design Guidelines for XHD2 DC Connectors

2.1. This section describes preferred DC connector design.

2.1.1. Stiffener/Organizer

2.1.1.1. DC connectors are configured to fit on a stiffener. Signal, guide, and power modules, and other components are configured on stiffeners according to customer specifications, usually determined by the design of customer's backplane slot. The stiffener keeps the DC components on 1.80 mm pitch.

2.1.1.2. XHD2 DC connectors are available with or without an extra ground on the A wafer. The extra ground version provides preferable signal integrity performance in some applications.

2.1.1.2.1. XHD2 DC with A wafer extra ground is mated to XCede HD PLUS (hereinafter XHD+) or XHD2 backplane module assemblies (hereinafter BMAs) with extra ground BMAs.

XHD2 DC without A wafer extra ground are mated to standard XCede HD (hereinafter XHD) BMAs or XHD2 without extra ground BMAs.

2.1.1.2.2. Contact ATCS FAE for recommended DC module design. See Figure X for profiles of DC modules with and without the extra ground lead on the A wafer.

Figure 1

XHD2 4 Pair Profiles with and without A Wafer Extra Ground

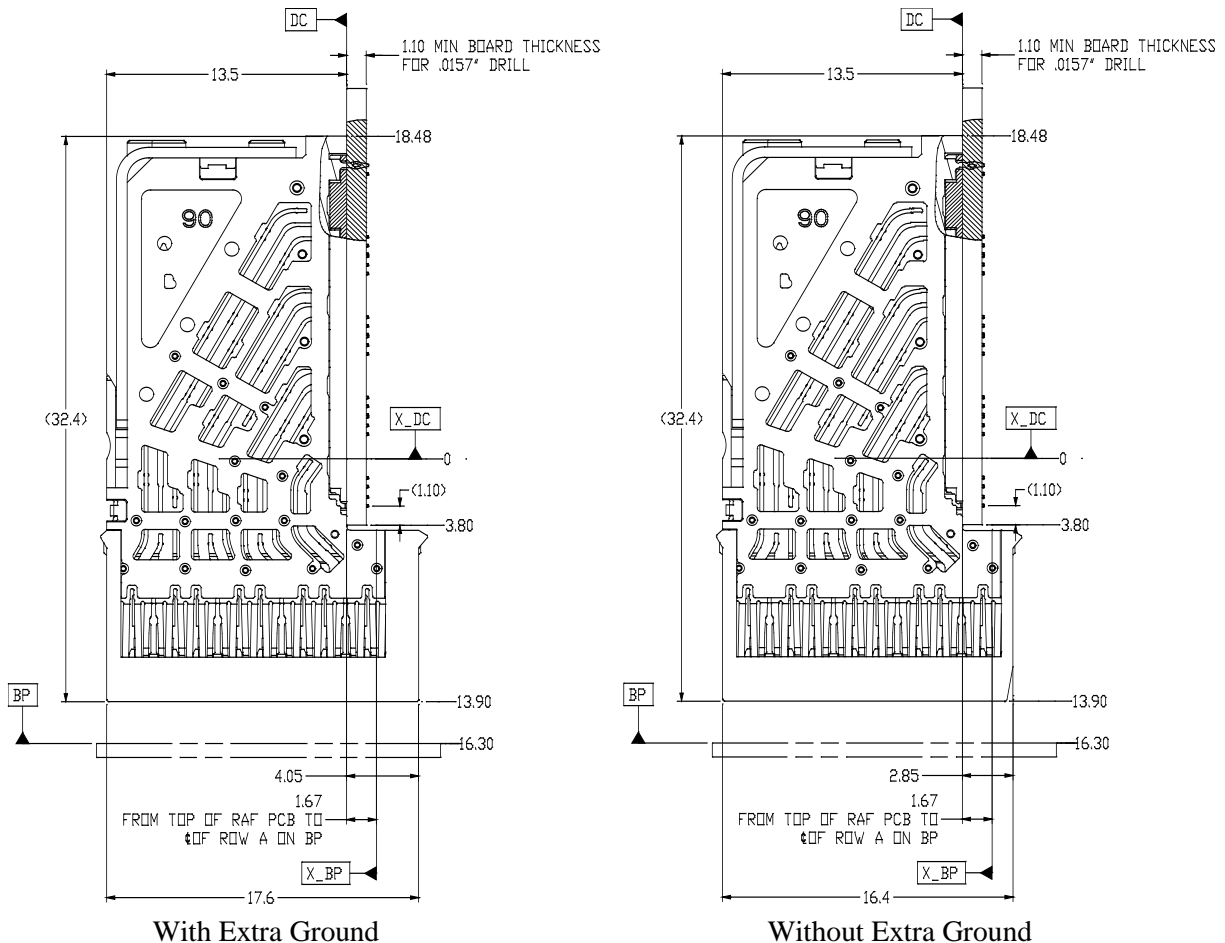

- 2.1.1.3. DC configurations may also be determined by the XHD2 RAM connector to which they will mate for co-planar applications. See section 4 regarding XHD2 RAM connectors.
- 2.1.1.4. The stiffener may help straighten the board edge, but this does not necessarily preclude the need for additional board stiffening.

2.1.2.DC Connector Configurations

- 2.1.2.1. DC connector configurations are determined by the customers' system application. For optimal connector configuration, connectors are grouped into signal modules of 4, 6, or 8 wafer increments. This matches the 4, 6 or 8 column groupings of BP modules. Guide and power modules are typically placed on the ends of the connector to protect DC connectors from handling damage. See Figure 2 for a typical connector configuration.

Figure 2
Typical XHD2 Connector Configuration

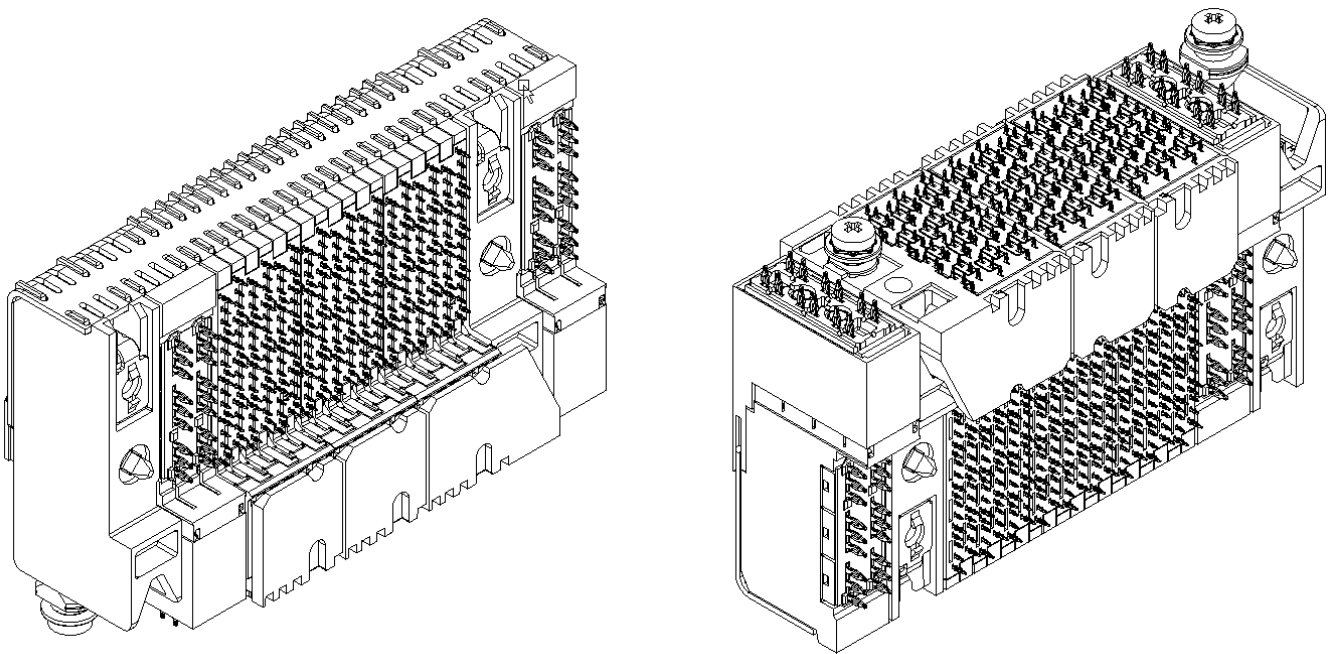

- 2.1.2.2. XHD connectors is not stiffener compatible and must be used on separate stiffeners. XHD+ can be stiffener compatible with XHD2 DC connector, no matter with or without A wafer extra ground.

Figure 3
XHD2 and XHD+ DC Connector

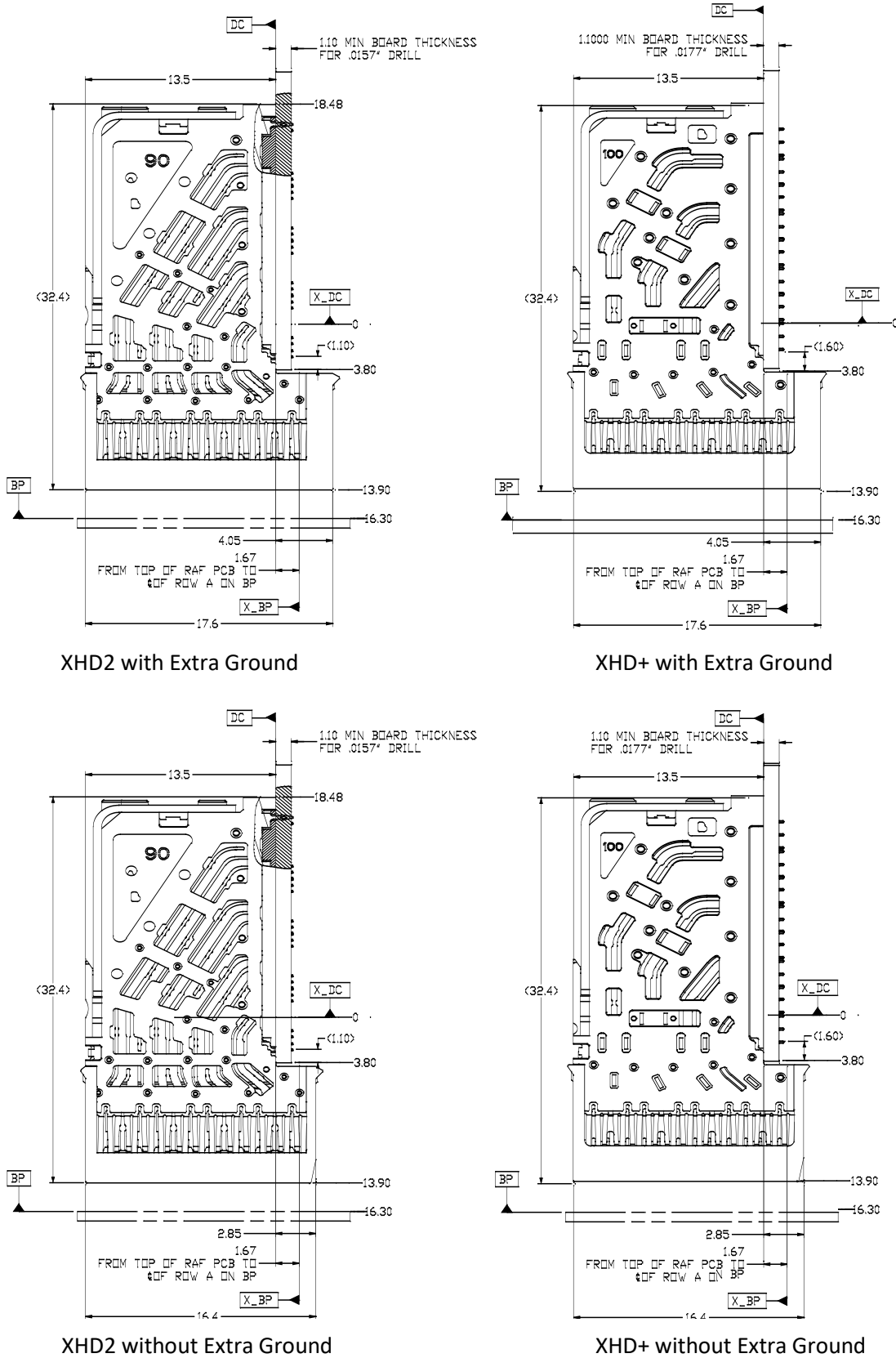
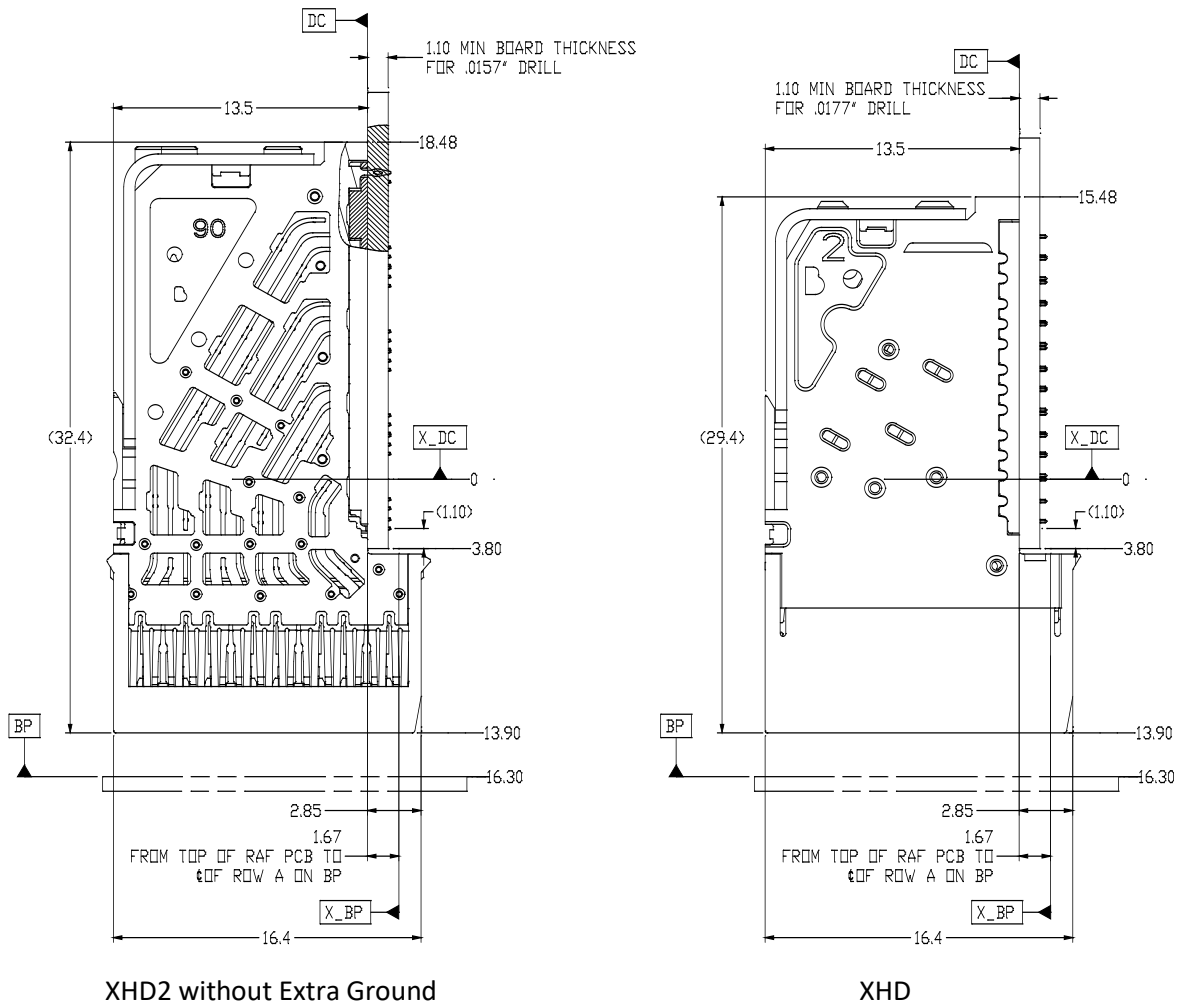

Figure 4
XHD2 and XHD DC Connector



2.1.3.DC Connector Length

2.1.3.1. Minimum DC connector length is determined by the minimum required number of signal modules and other components. For a standard configuration, the minimum number of signal modules is one (1). Maximum DC length is dependent on the number of signal modules. Refer to Table 1 for maximum lengths.

Table 1 Maximum DC Lengths	
XHD2 Product Family	Maximum Allowable DC Length in Millimeters
3 Pair	203.2 mm
4 Pair	203.2 mm
6 Pair	152.4 mm

2.1.3.2. When power modules are used, the minimum number of power modules on a stiffener is one (1), and at least one screw-down guide module must be used adjacent to the power module.

2.1.3.3. If it is necessary to design a connector that is longer than the maximum allowable DC length, then the connector must be divided into segments, with each segment not to exceed the maximum allowable DC length within the applicable product family. For example, a 300 mm 4 Pair connector must be divided into at least two separate segments, with the longest segment not to exceed 203.2 mm in length. Contact ATCS FAE regarding DC connectors exceeding 508 mm in length.

2.1.4. Guidance and Keying

2.1.4.1. With increasing density and connectors with higher pin counts, a robust guidance system is a critical design element. The XHD2 connector system relies on sequential funneling to ensure proper mating. The first phase is gross alignment, provided by card cage guides as the DC approaches the BP. XHD2 guide pins and guide modules provide the next phase of alignment. Alignment ribs on signal module front housings and alignment slots on BP modules support the last and final alignment phase. Many design considerations must be taken into account when determining the guidance requirements. Some of these include:

- connector length;
- DC weight;
- guide pin gathering ability
- connector orientation (vertical or horizontal)
- Card guide(s) clearance amount; and
- multiple "separate / different" connectors on the same card edge.

2.1.4.2. Connector length will help to determine the number of guide pins required. When guide modules are used, the minimum number of guides on a stiffener is one (1).

DC Connector Length in Millimeters	Recommended Minimum Guide Pin Quantity
150 mm or less	One (1) guide pin, minimum
150 mm to 360 mm	Two (2) guide pins, one (1) at each end of the connector
360 mm or greater	Contact ATCS FAE

2.1.4.3. It is not recommended to use more than three (3) guide pins, due to the probability of 'binding'. Using too many guide pins could allow the guides to work against each other due to the tolerance stack-up of the chassis and connector system. However, in some rare applications with heavy DCs (greater than 30 pounds), three (3) guide pins have been used. Contact ATCS FAE to review applications potentially requiring more than three (3) guide pins.

- 2.1.4.4. The weight of the DC assembly will also help to determine the type of guide pin or guide module used.

Table 3 XHD2 DC Guide Pin Weight Capacity Requirements	
DC Assembly Weight	Guidance System Requirements
5 lbs or less	Use standard plastic mounted guide pin and standard receptacle; minimum of one (1) guide pin.
5 lbs to 10 lbs	Use two (2) standard plastic mounted guide pins and standard receptacle; or use one (1) free standing board mounted guide pin with standard guide receptacle.
10 lbs to 15 lbs	Use two (2) free standing board mounted guide pins with standard guide receptacle.
15 lbs or greater	Use wide guide board mounted pin.

- 2.1.4.5. The XHD2 DC system will offer two (2) primary guidance systems, (1) the standard guide module receptacle; and (2) the wide guide. Additionally, there will be an electro-static discharge (hereinafter ESD) guide module for 3, 4 and 6 Pair connectors. As of the initial release of this document, no wide guide has been tooled and no ESD guide has been tooled. Contact ATCS FAE for guide module availability information.

2.1.4.6. Torque Recommendations

- 2.1.4.6.1. The customer is responsible to determine the torque requirements necessary for the installation of guide modules and/or guide pins within the customer's application. Torque can vary depending on the driver being used as well as other factors. ATCS offers the following suggested starting points to assist customers in determining the correct torque.

Table 4 Torque Recommendations	
Machined guide pin (2-56 machine screw)	2.0 inch pounds
Plastic and/or die cast guide module	2.0 inch pounds

- 2.1.4.7. XHD2 guidance is capable of gathering up to 2 mm radial for the standard guide pin and 3 mm radial for the wide guide pin. See (Figure 4).

Figure 5
XHD2 Standard Guide Gathering Ability

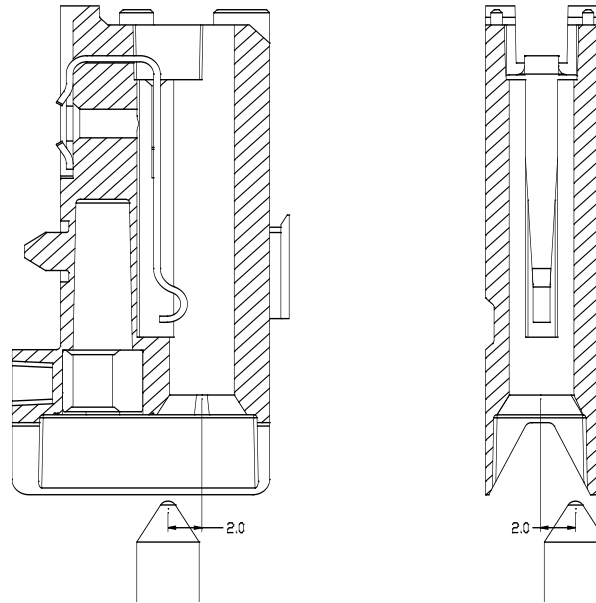
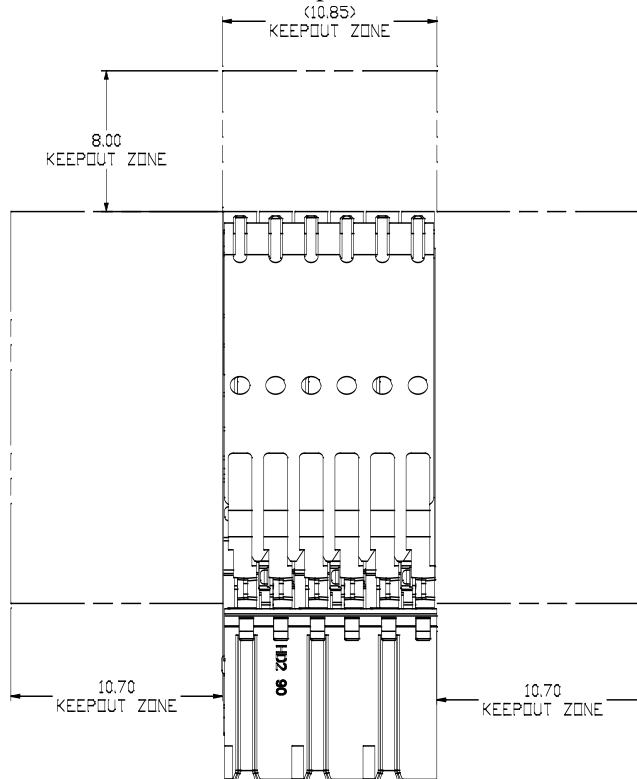

Figure shows standard guide. Wide guide has not yet been designed.

2.1.5. Surface trace and keep out zone.

Surface traces are not recommended. If surface traces are used refer to the customer drawings for keep-out zones. please refer to C919- series drawings.

Figure 6
XHD2 Keep out zone



2.1.6.DC Connector Configurations – End Stacking

2.1.6.1. In general, XHD2 DC may be stacked end to end with other on 1.80mm pitch, expect XHD+ DC modules with embedded capacitors (caps) have an extra protrusion to facilitate cap placement. This protrusion required 0.40mm additional place or 1.80mm pitch if install into one stiffener

Figure 7
XHD2 DC Connector with XHD+ DC Configurations – End Stacking

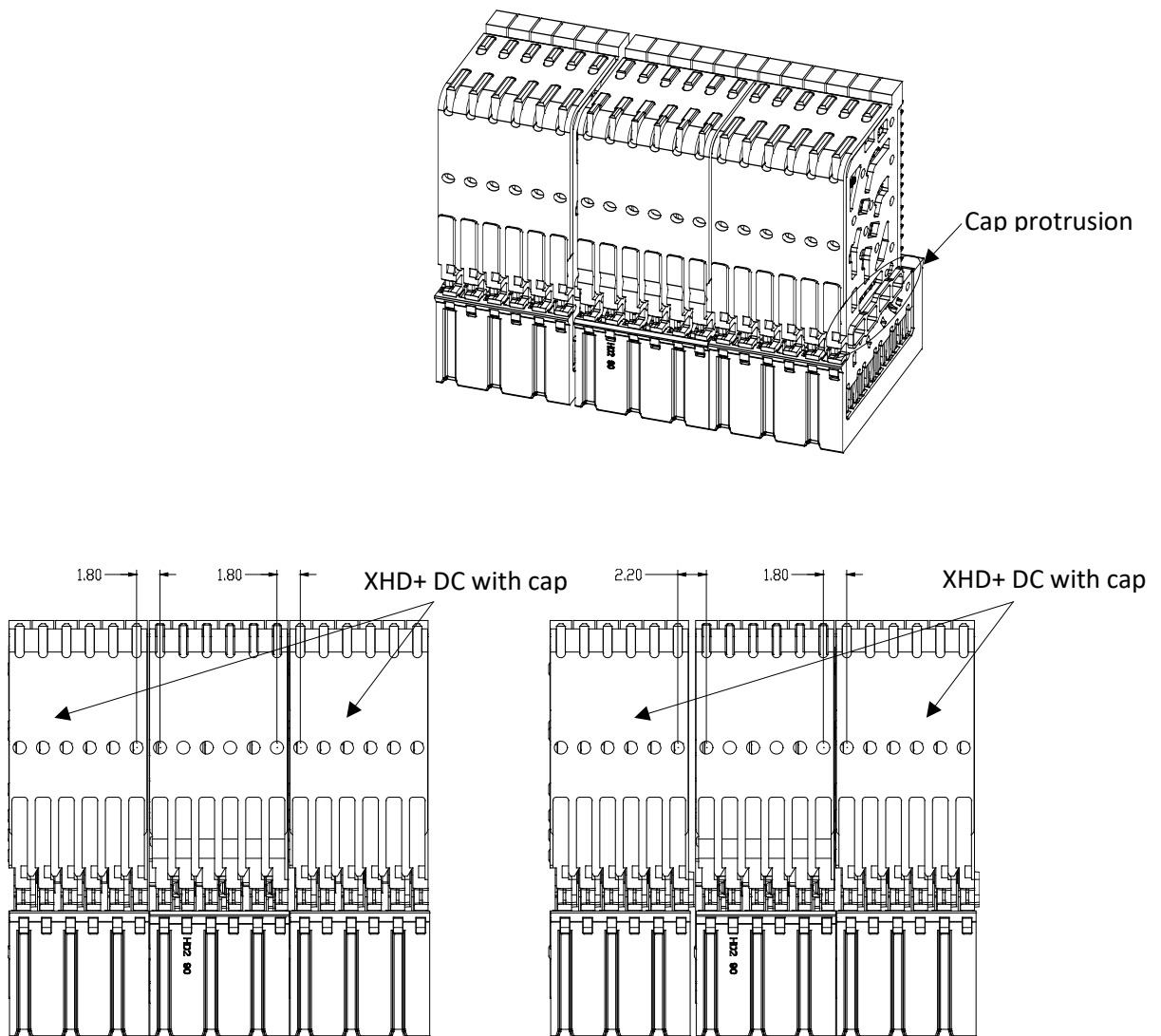

Figure 8
XHD2 DC Connector with Guide & Power Configurations – End Stacking

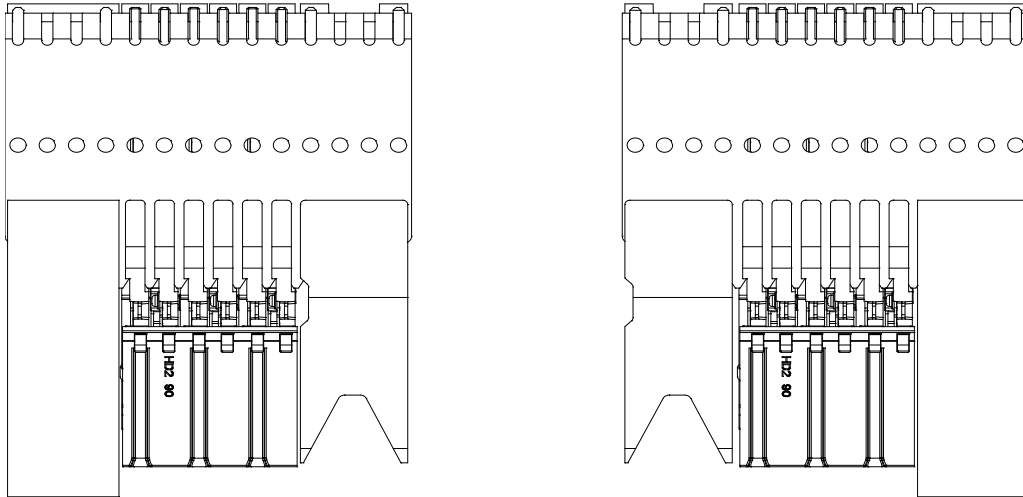
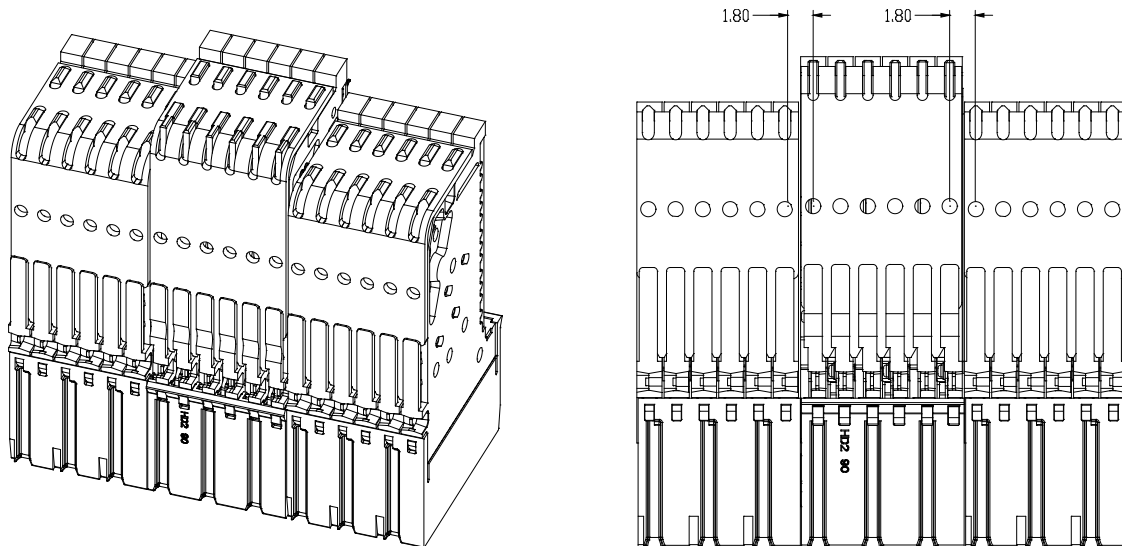

Figure 9
XHD2 DC Connector with XHD DC Configurations – End Stacking



3.0 Design Guidelines for BP Connectors

3.1. This section describes preferred BP connector design.

3.1.1. BP connectors are typically arranged in 4, 6 and 8 column modules. These are sometimes referred to as 4, 6, and 8 ‘position’ modules. BP modules may be available as ‘opens’ and/or with left and right polarizing/guided modules. Contact ATCS FAE for availability of various XHD2 BP module styles and position lengths.

3.1.2. Left and right polarizing/guided modules have integrated standard guide pins. The integrated plastic mounted guide pins can be used with or without board mounted screws. Screws are preferred in all applications for increased robustness.

3.1.3. BP Connector Configurations – End Stacking

3.1.3.1. XHD2 BP modules can be configured in various combinations. See Figure 10 for a typical XHD2 BMA configuration.

Figure 10
Typical XHD2 BP Configuration

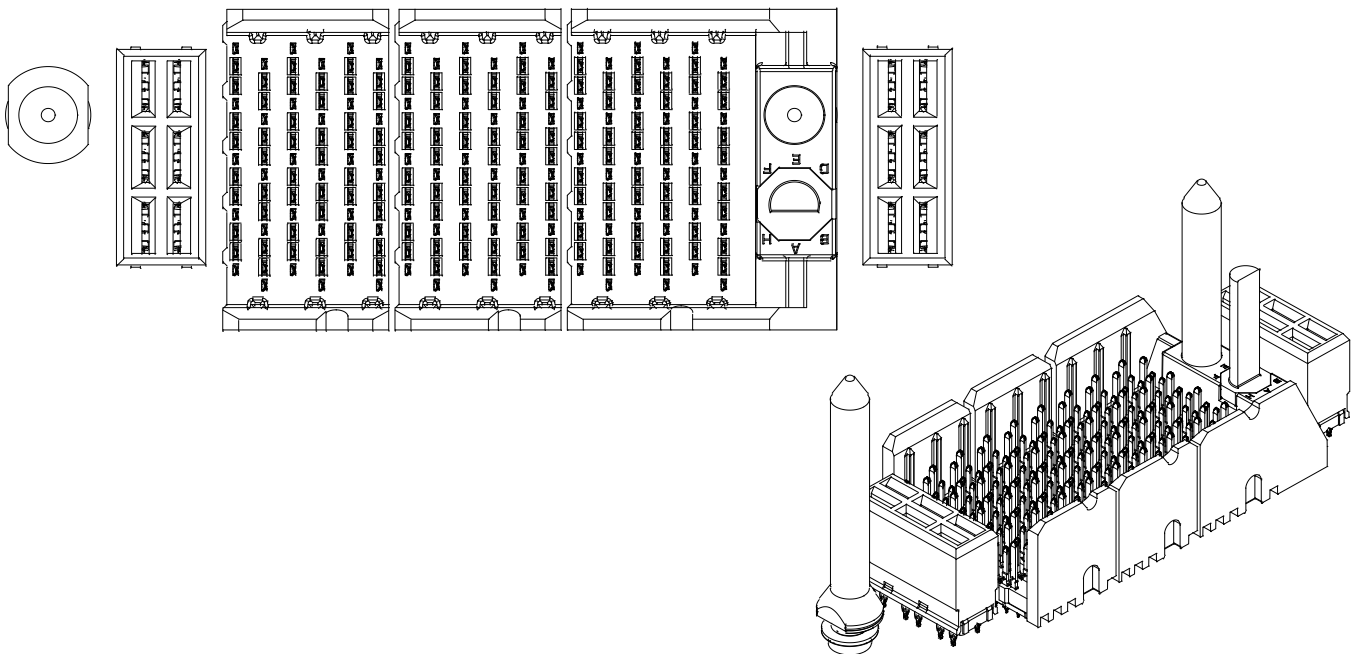

3.1.3.2. XHD2 BP connectors may be stacked end to end with each other on 1.80 mm pitch. XHD2 BP modules can be stacked end to end with XHD & XHD+ BP modules.

Figure 11
XHD2 BP and XHD BP Modules Stacked

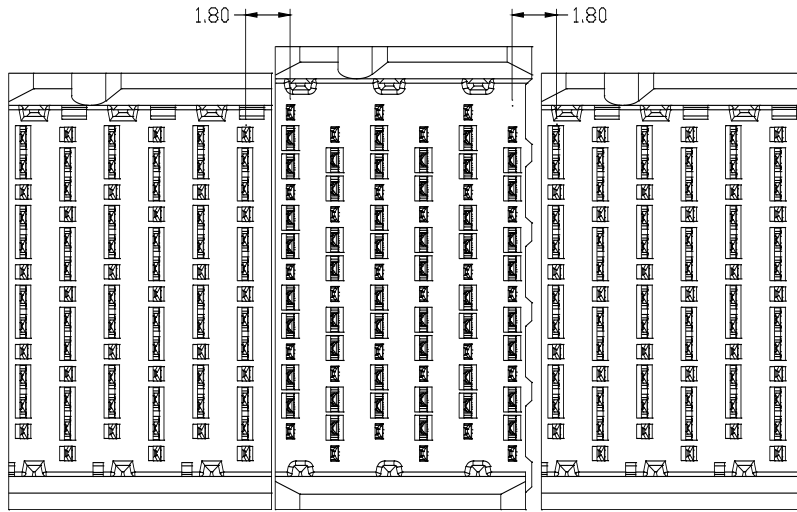

Figure 12
XHD2 BP and XHD+ BP Modules Stacked

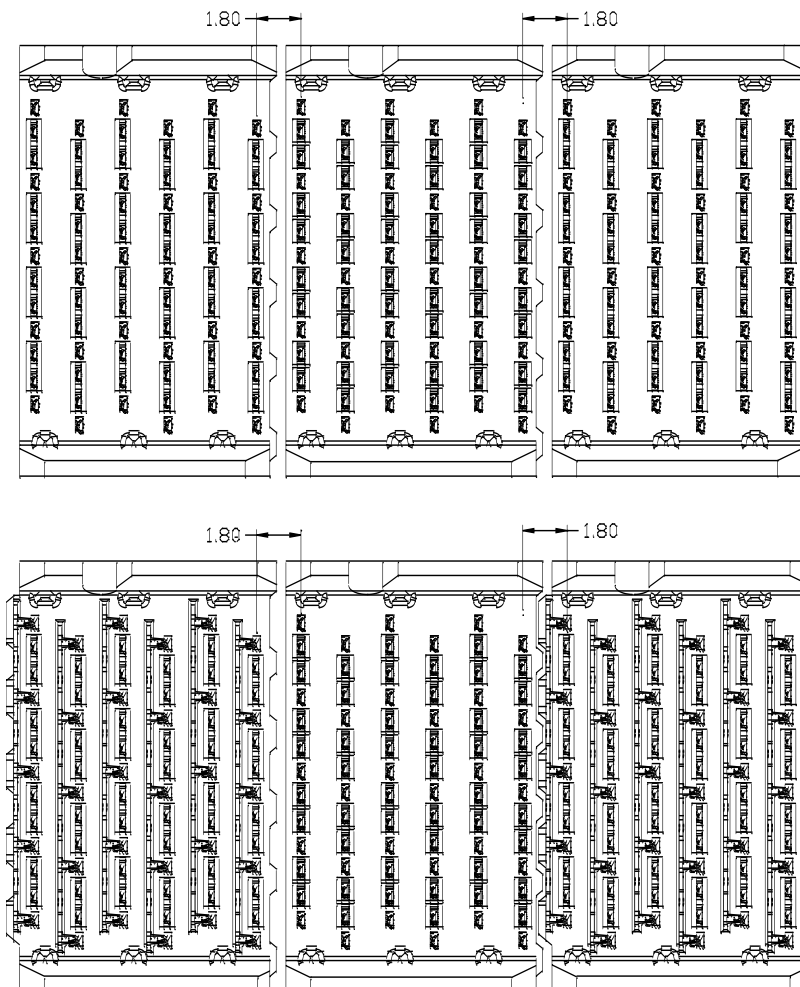
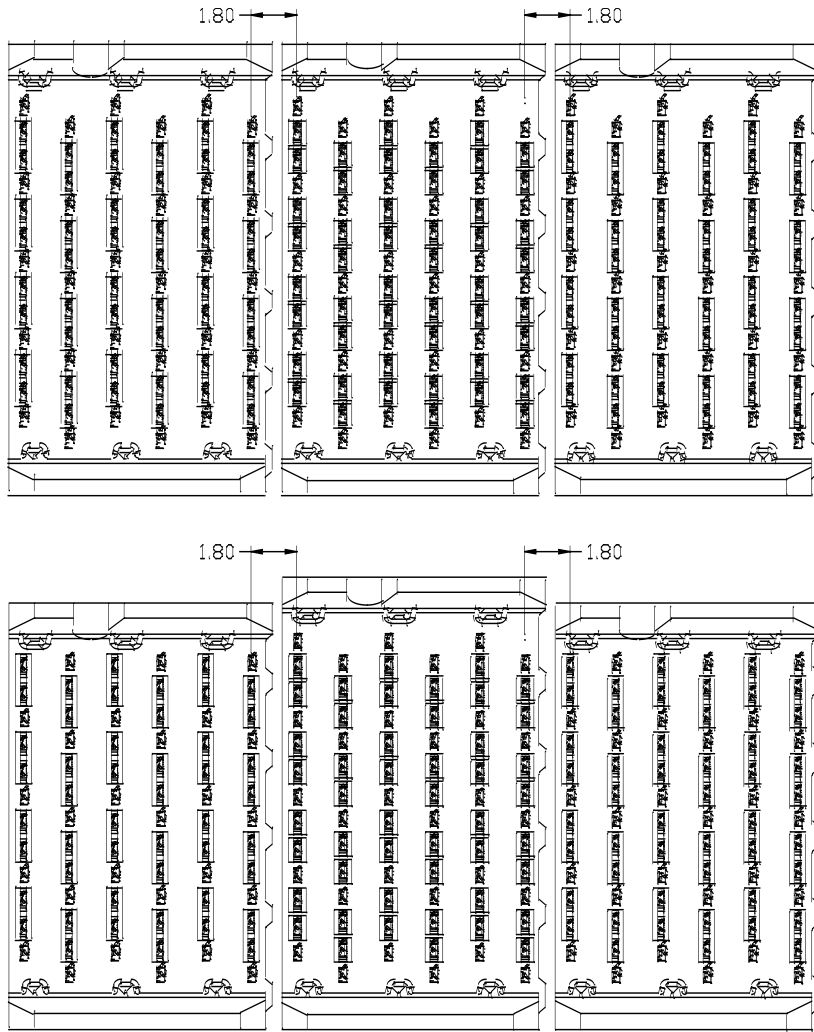

Figure 13
XHD2 Modules Stacked



3.1.4. BP Power

- 3.1.4.1. The BP power module may not be placed within 1.8 mm of the right hand side of the BP connector. However a BP power module may be placed immediately adjacent to the left hand side of a BP connector. See Figure 14 illustrating space requirements between BP modules and BP powers.

Figure 14
Spacing Requirements Between XHD2 BP Modules and XHD2 BP Powers

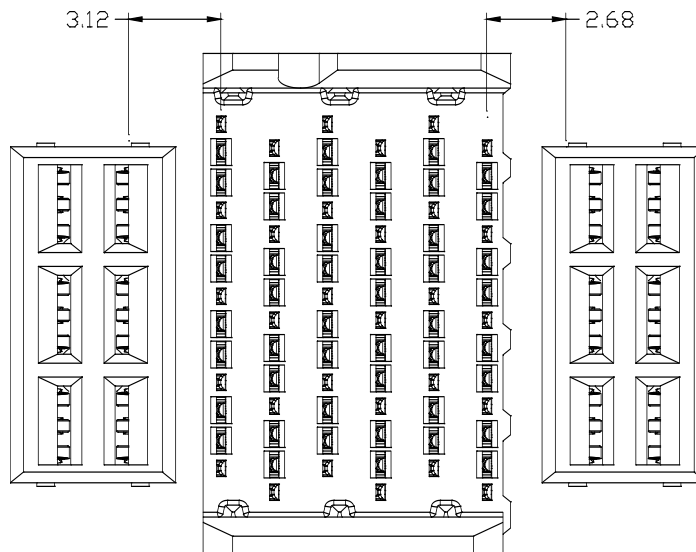

4.0 Design Guidelines for Co-Planar (RAM) Connectors

- 4.1. This section will eventually describe preferred XHD2 RAM and/or XHD2 IRAM connector design. As of the initial release of this document, neither XHD2 RAM nor XHD2 IRAM has not been designed. Meantime, refer to XHD RAM connector design guidelines described in TB-2272.

5.0 Power (Current Ratings)

5.1. Signal and Shield Contacts

See Figure X for current ratings per contact with an operating temperature range of -40°C to 105°C.

Table 5 Signal and Shield Contact Current Rating	
Contact Type	Current per Blade (Amp)
Signal	1.5
Shield/Ground	Not Recommended

5.2. Power Connector

5.2.1.XHD2 DC powers will be available in two (2) mechanical lengths. See Table X for minimum wipe length requirements.

Table 6 Power Minimum Wipe Length Requirements		
Length of DC Lead	Short Beam Wipe Length	Long Beam Wipe Length
4 mm	2.6 mm	3.6 mm
5mm	3.6 mm	4.6 mm

6.0 Connector Mating Sequence

6.1. Mating Sequence

XCede HD2 3 Pair Mating Sequence

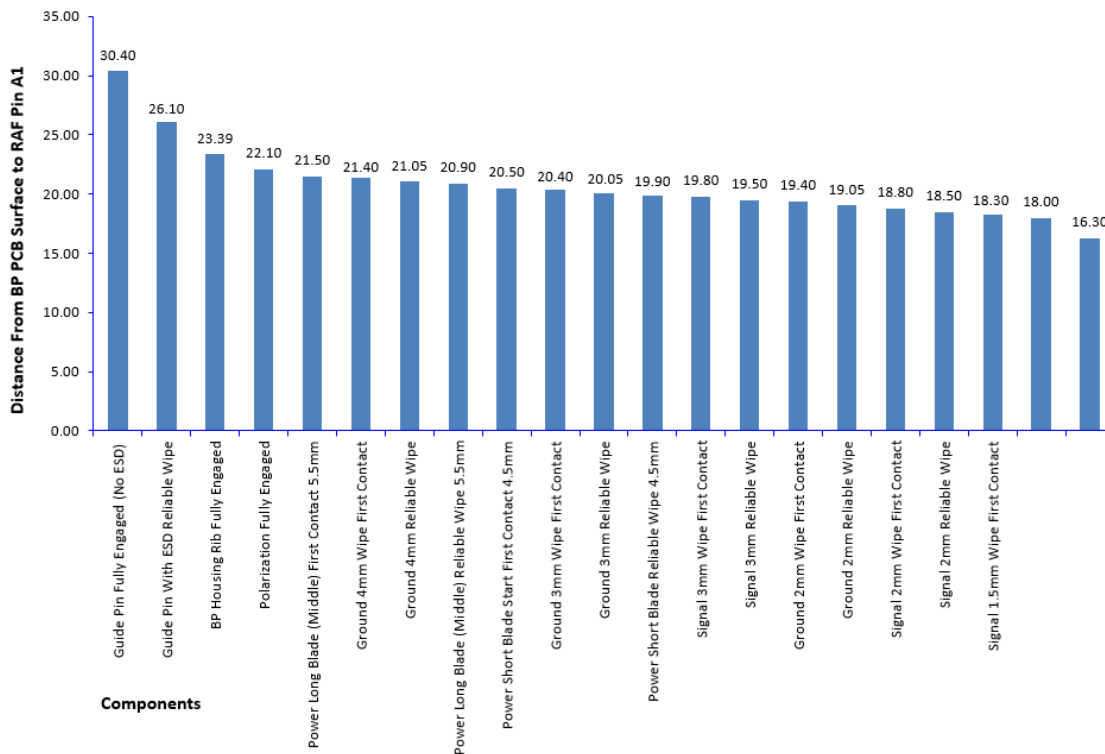

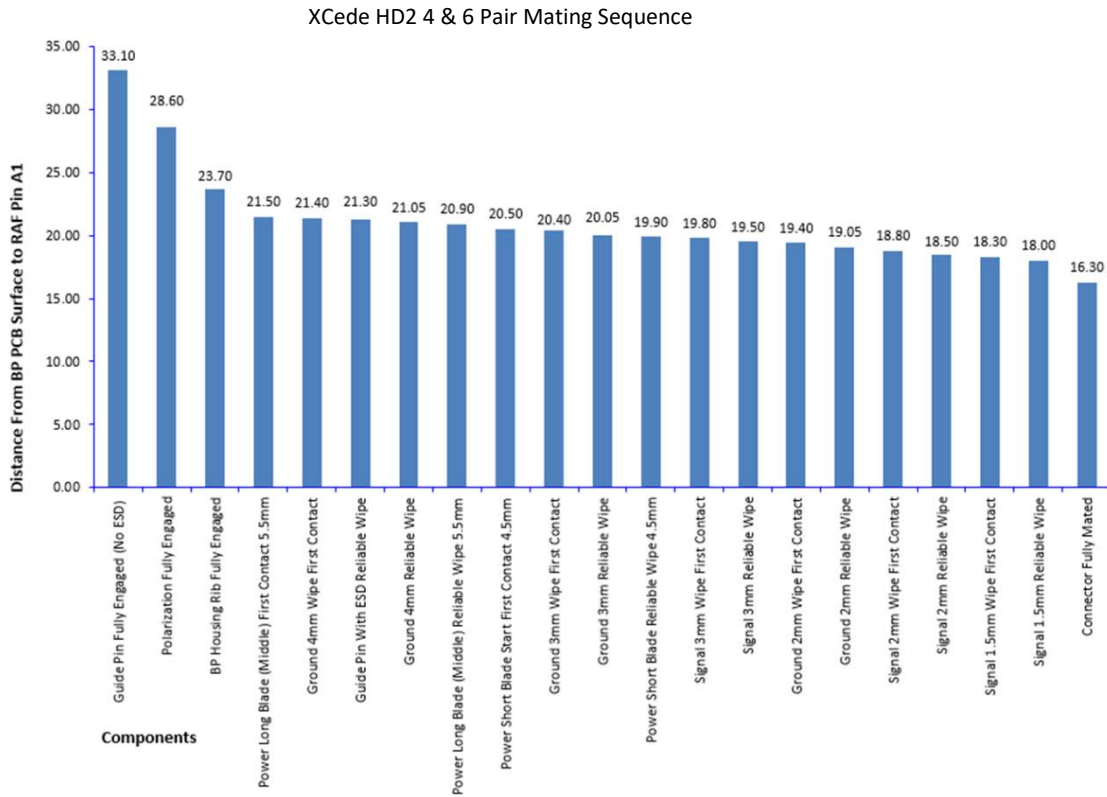

Figure 15: XHD2 Mating sequence

7.0 Printed Circuit Board (PCB) Considerations

7.1. Refer to TB-2237 for signal trace routing guidelines.

Table 7 XHD2 Connector Density and Slot Pitch		
Configuration	Connector Density	Slot Pitch
3 Pair	42 pairs per inch (16 per centimeter)	1.80 mm
4 Pair	56 pairs per inch (22 per centimeter)	1.80 mm
6 Pair	84 pairs per inch (33 per centimeter)	1.80 mm

8.0 Mated Mechanical Lengths

8.1. Refer to TB-2343 General Product Specification for XHD2 BP and DC Interconnect System.

9.0 Mid-Plane Applications

9.1. Refer to TB-2237 for signal trace routing guidelines.

10.0 Connector Pressing

10.1. DC Pressing

10.1.1. Refer to TB-2244 for DC press fit installation process.

10.2. BP Pressing

10.2.1. Refer to TB-2252 for BP press fit installation process.

11.0 Customer Use Documentation

11.1. Customer use documentation is available at the DC connector, BP connector, DC module, power module, and guide module levels. Visit www.amphenol-tcs.com and/or contact ATCS FAE for customer use documentation.

11.2. DC Connector Part Numbering

Table 9 XHD2 DC Connector Part Numbering Lead-Offs					
2 Pair	3 Pair	4 Pair	6 Pair	8 Pair	Description
CAX235	CAX335	CAX435	CAX635	CAX835	Right angle female (RAF), 1.80 mm pitch, no extra ground, lead free, standard plating
CAX236	CAX336	CAX436	CAX636	CAX836	Right angle female (RAF), 1.80 mm pitch, with extra ground, lead free, standard plating
CJX235	CJX335	CJX435	CJX635	CJX835	Right angle female (RAF), 1.80 mm pitch, no extra ground, lead free, advanced plating
CJX236	CJX336	CJX436	CJX636	CJX836	Right angle female (RAF), 1.80 mm pitch, with extra ground, lead free, advanced plating

11.3. BP Connector Part Numbering

Table 10 XHD2 BMA Connector Part Numbering Lead-Offs					
2 Pair	3 Pair	4 Pair	6 Pair	8 Pair	Description
C972-2	C972-3	C972-4	C972-6	C972-8	XHD2 BMA

Table 11 XHD2+ BMA Connector Part Numbering Lead-Offs					
2 Pair	3 Pair	4 Pair	6 Pair	8 Pair	Description
C973-2	C973-3	C973-4	C973-6	C973-8	XHD2+ BMA