

PRODUCT NUMBER
10119333-YXX-XXLF

PLATING
1=0.76µm GXT/GOLD ON CONTACT
2µm TIN MIN ON TAILS
4=2µm TIN MIN FULL PLATED

RoHS COMPATIBLE
NOTE 4

TOTAL NUMBER OF
POSITIONS :
02 TO 15 POS

PACKAGING, NOTE 3

STYLE	DIM "A" ±0.2
01	5.84
02	8.08
03	10.67
04	3.00

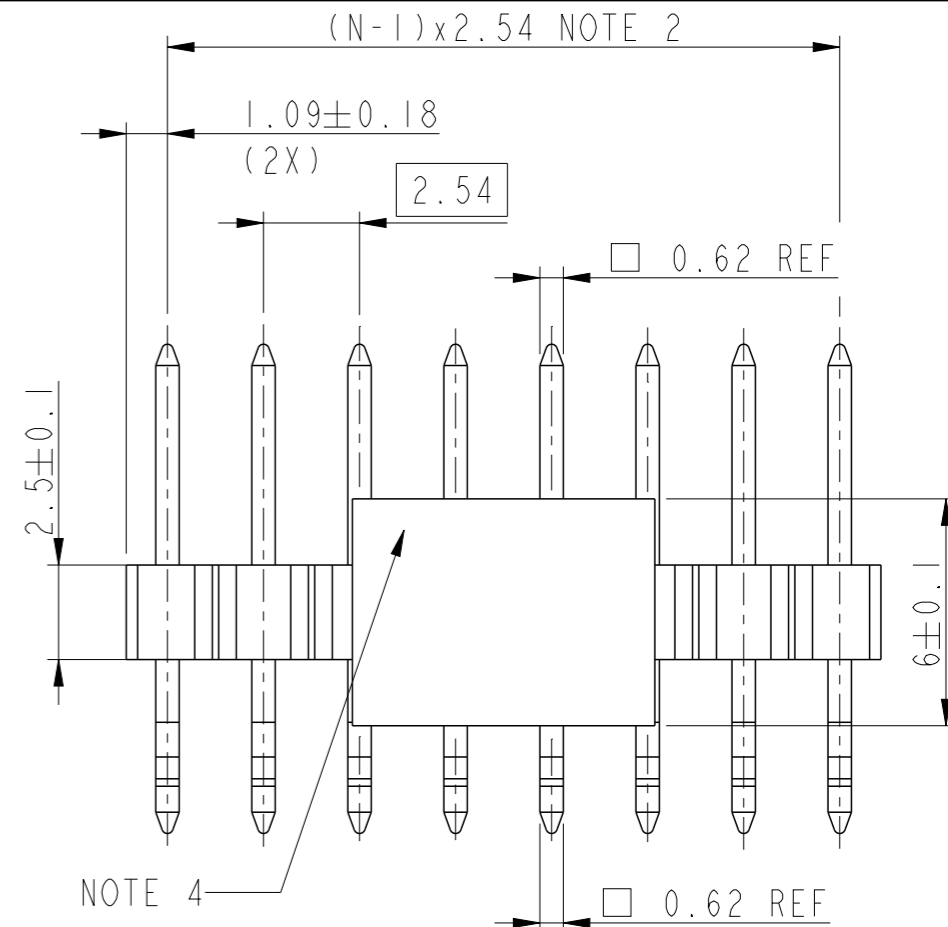
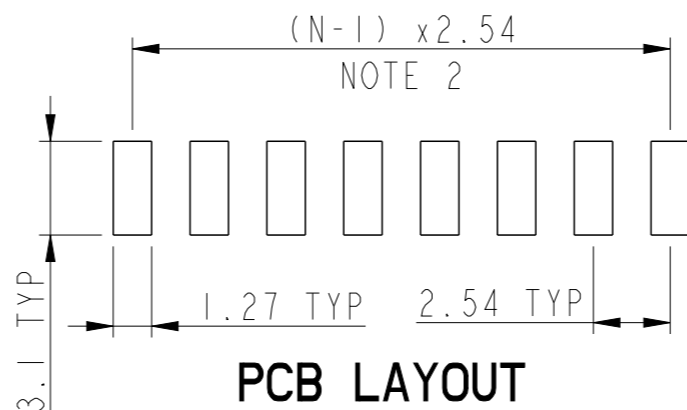

NOTES:

- 1- MATERIAL:
 - BODY: HIGH TEMPERATURE THERMOPLASTIC UL94V-0 COLOR BLACK
 - PIN : COPPER ALLOY
- 2 - TO DETERMINATE DIMENSIONS :
N = NUMBER OF POSITIONS
EXAMPLE : 8 POS x 2.54=20.32
- 3 - PACKAGING:
A = TAPE & REEL PACKAGING WITH PICK -UP CAP AS PER GS-14-2357
K = T&R PACKAGING WITHOUT PICK UP CAP, AS PER GS-14-2357
- = POLYBAGS
- 4 - RoHS COMPATIBLE PRODUCT SPECIFICATIONS :
 - a - PLATING :
"LF" MEANS THE PRODUCT IS LEAD FREE
2µm MINIMUM MATTE TIN OVER 1.27µm MINIMUM NICKEL UNDERPLATED
 - b - MANUFACTURING PROCESS COMPATIBILITY :
THE HOUSING WILL WITHSTAND EXPOSURE TO 260°C PEAK TEMPERATURE FOR 30 SECONDS MAX IN CONVECTION, INFRA-RED OR VAPOR PHASE OR REFLOW OVEN
 - c - LABELLING :
MEETS PACKAGING SPECS AS PER GS-14-920
 - d - LEGAL STATEMENT : SEE GS-47-0004
- 5 - PRODUCT SPECIFICATIONS AS PER BUS-12-114 EXCEPT PIN RETENTION FORCE 5N MIN.

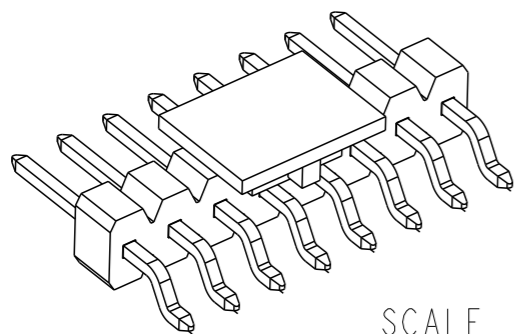
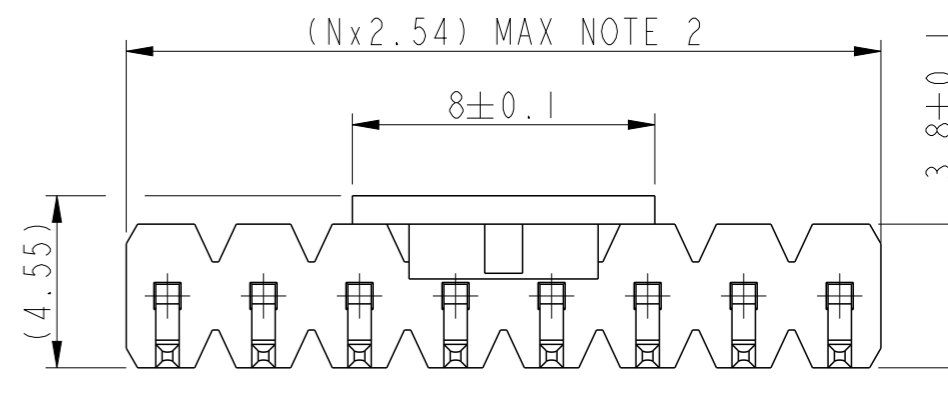
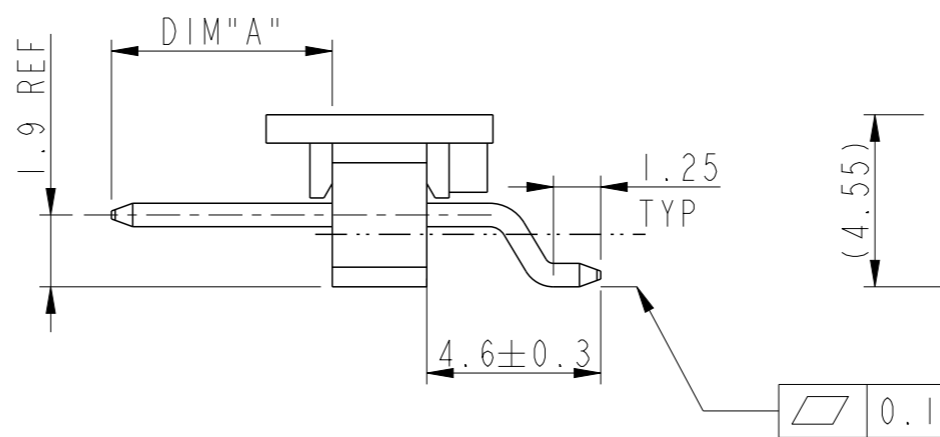

SCALE 3:1

spec ref	dr	Aymeric Souidy	2014/02/21	projection	MM	size	A3	scale	5:1
tolerance std	eng	Laurent Mulin	2020/04/22			ecn no	ELX-F-36816-1	rel level	Released
ISO 406 ISO 1101	chr	-	-						
surface	linear	0.X	±0.3		product family	BSTIK	dwg no	10119333	rev
		0.XX	±0.13						
ISO 1302	angular	0°	±2°						
TOLERANCES UNLESS OTHERWISE SPECIFIED		Amphenol FCI		2.54mm UNSH HEADER HORIZ		cat. no.		Product - Customer Drw	
www.fci.com		www.fci.com		SINLE ROW SMT		Product - Customer Drw		sheet 1 of 1	

Amphenol FCI

© 2016 AFCI