

PRODUCT NUMBER
SEE PART NO. TABLE

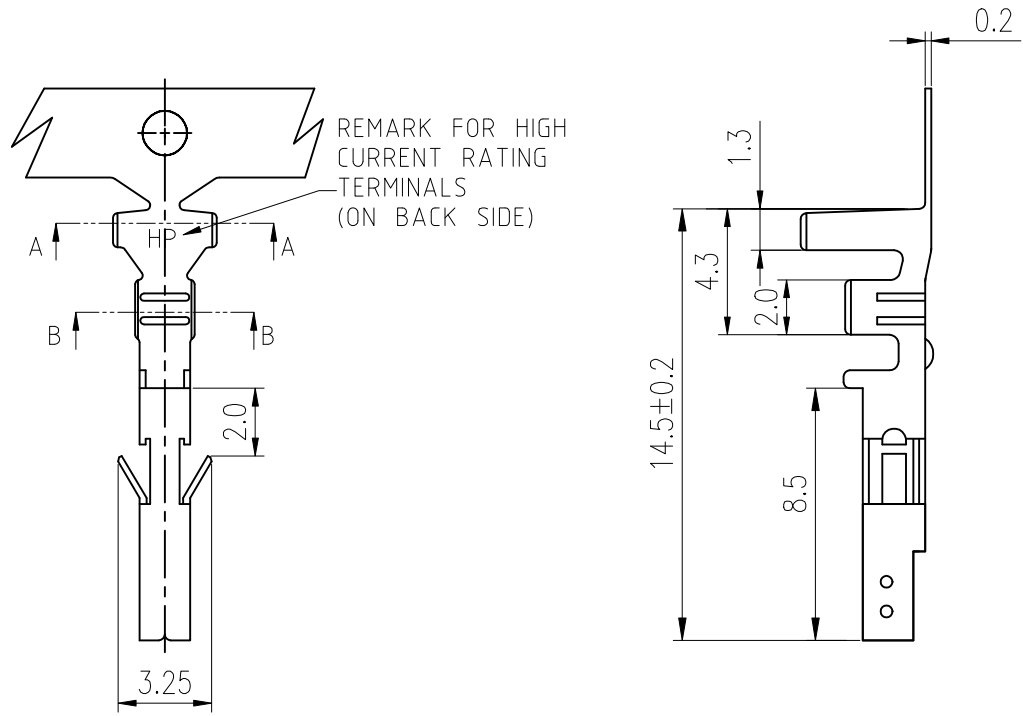

REMARK FOR HIGH CURRENT RATING TERMINALS (ON BACK SIDE)

- NOTES:
- MATERIAL: HIGH CONDUCTIVITY COPPER ALLOY.
 - PLATING :
CONTACT AREA : OPTIONAL
CRIMP AREA : 80μ" MIN. BRIGHT TIN
UNDER PLATING : MIN. 30μ" SEMI BRIGHT NICKEL OVERALL
 - REFER GS-20-0401 APPLICATION SPEC FOR MATING CONNECTOR.
 - PRODUCT SPECIFICATION: GS-12-1333, GS-12-1626.
 - REEL PACKING SPECIFICATION: GS-14-2362.(REEL PACKING)
 - APPLICATION SPECIFICATION : GS-20-0401
 - LEAD FREE PRODUCTS MEET EUROPEAN UNION DIRECTIVES AND OTHER COUNTRY REGULATIONS AS DESCRIBED IN GS-47-0004
 - PART NUMBER SCHEME:
10136289 - 1 X 1 X LF

PLATING TYPE:
P: PRE-PLATED
BLANK: POST-PLATED

PLATING CODE:
1: GOLD FLASH
2: 80u" BRIGHT TIN OVERALL
3: 100u" MATTE TIN OVERALL
4: 30u" GOLD(NOT AVAILABLE FOR POST-PLATED OPTION)

9. DIMENSIONAL & PART NO. TABLE:

PART NO.	A	B	C	D	APPLICABLE WIRES
10136289-1X1XLF	3.7	4.5	1.8	2.7	#18~#22 MAX. OD: 3.1mm

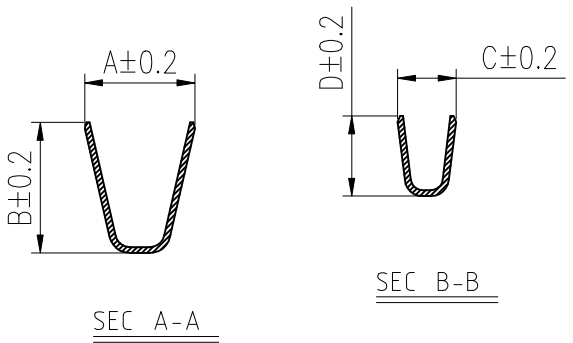

mat'l. code		surface ISO 1302 ✓		tolerance ISO 406 ISO 1101		projection mm		product family MINITEK PWR4.2 HCC	
ltr		ecn no		date		tolerances unless otherwise specified		title	
A		TAI		2015-07-27		angles linear		MINITEK PWR4.2 REC TERMINAL	
B		ELX-T-24718		TAI		2016-09-22		HIGH CURRENT RATING	
C		ELX-N-27760		TONY		2017-08-16		scale NTS	
D		ELX-I-43590		SONY		2023-01-09		sheet 1 of 1 size	
				dr		KENNY TAI		2015-07-23	
				enrg		SONY		2023-01-09	
				chr		SONY		2023-01-09	
				appd		MITHUN		2023-01-09	
sheet index		revision sheet		D				type Product Customer Drawing	
		1							