

PRODUCT NUMBER  
SEE PART NO. TABLE

- NOTE:
- MATERIAL:  
HOUSING: HIGH TEMP. NYLON, UL94V-0, HALOGEN FREE, COLOR: OPTIONAL  
CONTACT: HIGH CONDUCTIVITY COPPER ALLOY.
  - CONTACT FINISH: NICKEL 50u" Min. UNDERPLATED OVERALL.  
OPTIONAL PLATING ON CONTACT AREA, 100u" MIN MATTE TIN ON SOLDER TAIL.
  - REFER GS-20-0399 APPLICATION SPECIFICATION FOR MATING CONNECTOR.
  - PRODUCT SPECIFICATION: GS-12-1291.
  - PACKAGE SPECIFICATION: GS-14-2419.
  - APPLICATION SPECIFICATION: GS-20-0399
  - THE HOUSING WILL WITHSTAND EXPOSURE TO 260°C PEAK TEMPERATURE FOR 10 SECONDS IN A REFLOW OVEN.
  - LEAD FREE PRODUCTS MEET EUROPEAN UNION DIRECTIVES AND OTHER COUNTRY REGULATIONS AS DESCRIBED IN GS-47-0004
  - PART NUMBER SCHEME:  
10142730- XX X X X X LF

POS CODE: XX X X X X LF  
 02: 2 POS  
 03: 3 POS  
 12: 12 POS

LEAD FREE  
 PACKAGE:  
 R: TAPE & REEL

HSG MATERIAL:  
 G: HIGH TEMP NYLON

PLATING CODE:  
 1: GOLD FLASH OVERALL  
 2: 100u" Min. MATTE TIN OVERALL  
 4: 30u" Min GOLD ON CONTACT AREA,  
 100u" Min MATTE TIN ON TAIL

HSG COLOR:  
 1: BLACK

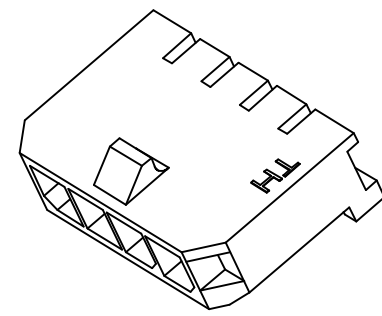
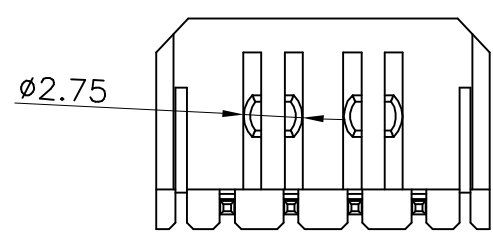
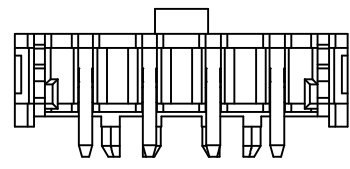
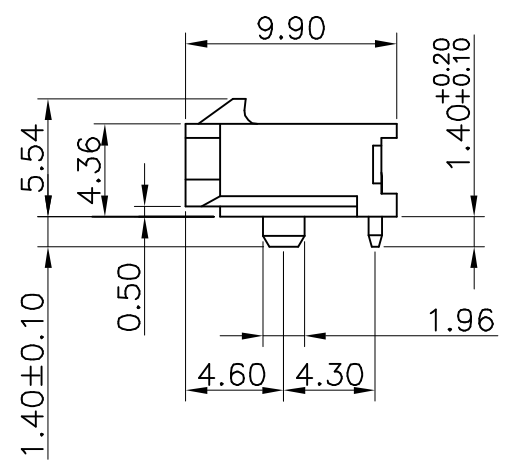
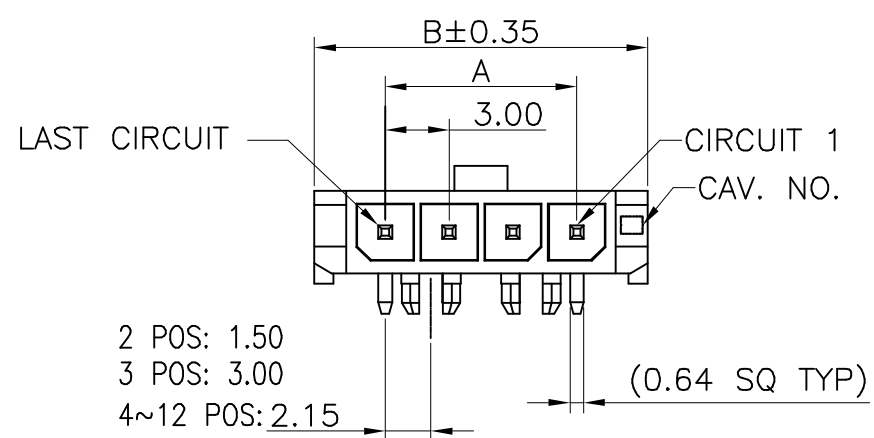
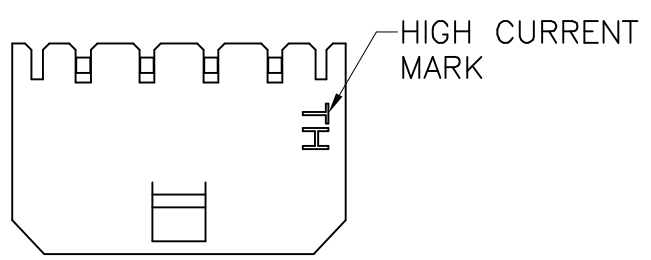

PART NUMBER	POS	A	B	COMMENT
10142730-02XXXXLF	2	--	9.65	
10142730-03XXXXLF	3	6.00	12.65	
10142730-04XXXXLF	4	9.00	15.65	
10142730-05XXXXLF	5	12.00	18.65	
10142730-06XXXXLF	6	15.00	21.65	
10142730-07XXXXLF	7	18.00	24.65	
10142730-08XXXXLF	8	21.00	27.65	
10142730-09XXXXLF	9	24.00	30.65	
10142730-10XXXXLF	10	27.00	33.65	
10142730-11XXXXLF	11	30.00	36.65	
10142730-12XXXXLF	12	33.00	39.65	

TOOLING ON REQUEST

mat'l. code		surface <input checked="" type="checkbox"/> ISO 1302		tolerance <input checked="" type="checkbox"/> ISO 406 ISO 1101		projection		product family MINITEK PWR 3.0 HCC	
ltr		ecn no		dr		date		title	
A		TONNY		2017-02-13				RIGHT ANGLE PIP HEADER	
B		ELX-I-43460 AKHIL		2022-01-21				SINGLE ROW HIGH CURRENT WTB	
				angles		linear		scale N.T.S	
				0°±5'				dwg no	
				dr		TONNY LENG 2017-02-13		sheet 1 of 2	
				enr		AKHIL RAJAN 2022-01-21		10142730	
				chr		MITHUN PAUL 2022-01-21		A3	
				appd		SPK 2022-01-21		type Product Customer Drawing	
sheet index		revision		B		B			
		sheet		1		2			

Amphenol FCI  
 2016 AFCI  
 ©  
 D



© 2016 AFCI

Amphenol  
FCi

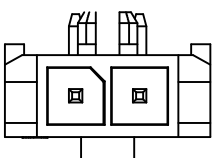

2 POS

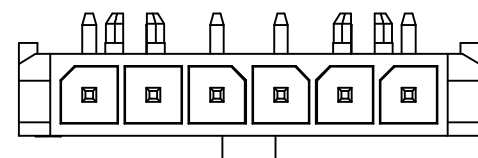

6 POS

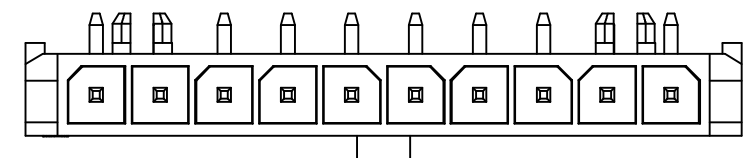

10 POS

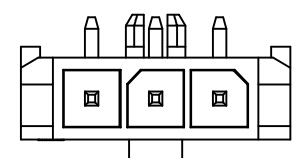

3 POS

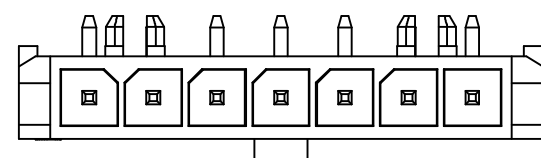

7 POS

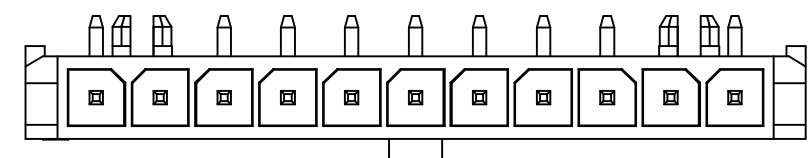

11 POS

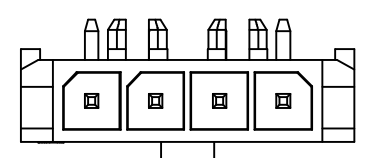

4 POS

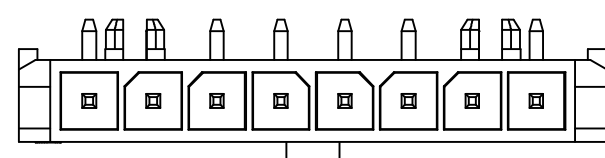

8 POS

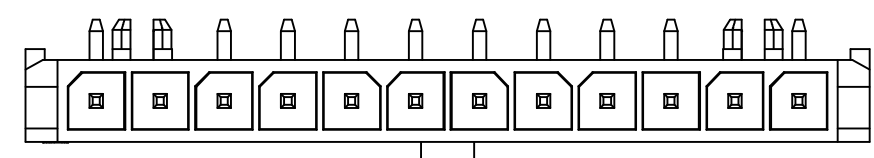

12 POS

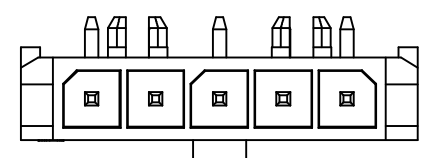

5 POS

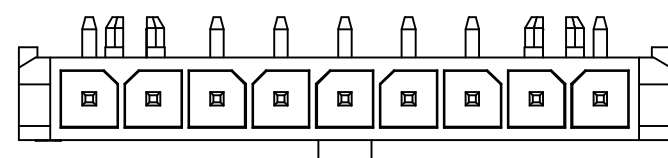

9 POS

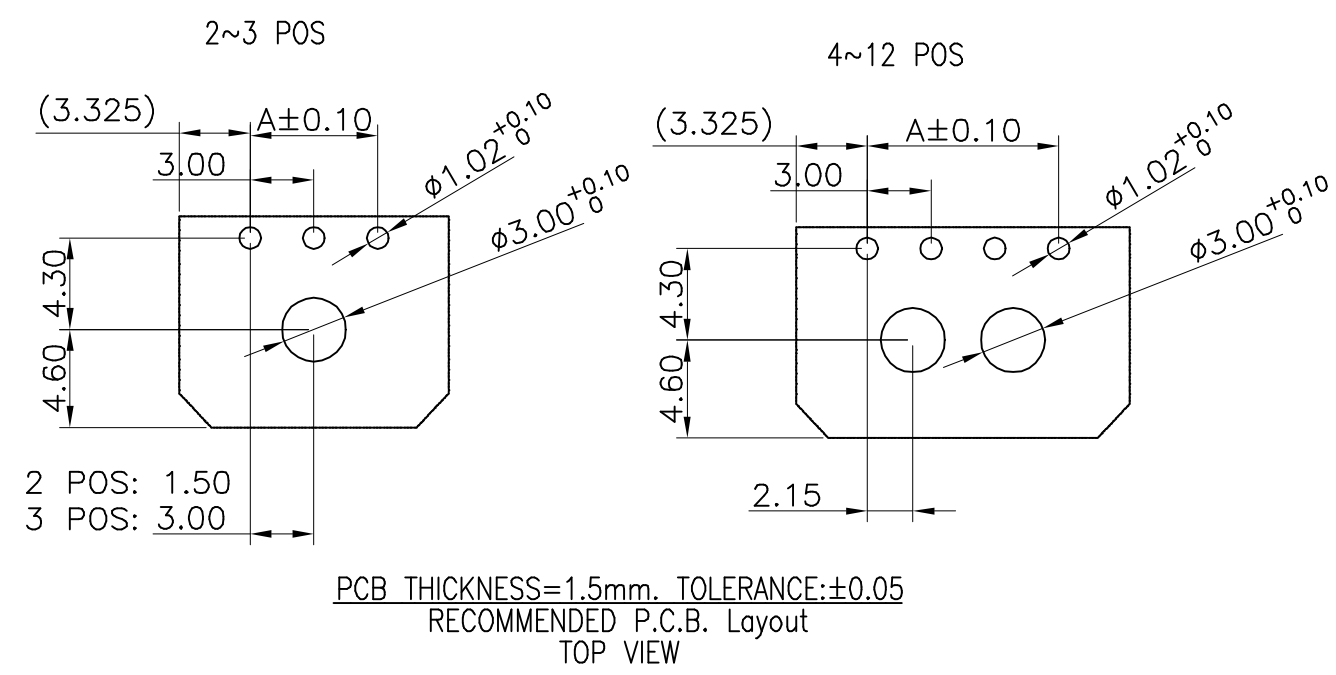

mat'l. code		surface		tolerance		projection		product family	
		ISO 1302 ✓		ISO 406 ISO 1101				MINITEK PWR 3.0 HCC	
ltr		ecn no		dr		date		title	
								RIGHT ANGLE PIP HEADER	
								SINGLE ROW HIGH CURRENT WTB	
						mm		scale N.T.S	
								dwg no	
								sheet 2 of 2	
								size	
								A3	
								type	
								Product Customer Drawing	
sheet index		revision		B		B			
		sheet		1		2			