

WE RECOMMEND THESE CONNECTORS FOR OPTIMAL SERVICE LEVEL



- SHORT LEAD-TIMES
- LOW MOQs
- QUICK SAMPLING
- AVAILABLE AT DISTRIBUTION



- 95278-101A04LF
- 95278-101A06LF
- 95278-101A08LF
- 95278-101A10LF
- 95278-101A12LF
- 95278-101A14LF
- 95278-101A16LF
- 95278-101A20LF

PLATING
 1 = 0.76µm GOLD/GXT ON CONTACT AREA
 2µm TIN MIN ON TAIL
 1.27µm Ni MIN UNDERLAYER

RoHS COMPATIBLE
 SEE NOTE 5
 TOTAL NB OF POSITIONS

PIN STYLE

PACKAGING
 A = TAPE & REEL WITH CAP, AS AVAILABLE
 CAUTION: CAP ON 95278-YXX-04LF IS ORIENTED 90° VERSUS OTHER NB OF POSITIONS

NOTES:

- HOUSING MAT'L : HIGH TEMPERATURE THERMOPLASTIC. UL94V-0 COLOR: BLACK
- PIN MATERIAL : PHOSPHOR BRONZE
- 9N MIN RETENTION IN EITHER DIRECTION
- TO DETERMINE DIMENSIONS :
 N = NUMBER OF POSITIONS PER ROW
- RoHS COMPATIBLE PRODUCT SPECIFICATIONS
 - PLATING:
 - "LF" MEANS THE PRODUCT IS LEAD-FREE, 2µm MINIMUM MATTE TIN OVER 1.27µm MINIMUM NICKEL UNDERPLATE.
 - MANUFACTURING PROCESS COMPATIBILITY
 - THE HOUSING WILL WITHSTAND EXPOSURE TO 260°C PEAK TEMPERATURE FOR 30 SECONDES IN A CONVECTION, INFRA-RED OR VAPOR PHASE REFLOW OVEN.
 - LABELING:
 - MEETS PACKAGING SPECS AS PER GS-14-920
 - LEGAL STATEMENT: SEE GS-47-0004
- THIS PART SERIES IS NOT INITIALLY INTENDED FOR AUTOMOTIVE APPLICATIONS. ADDITIONAL FEES ARE CHARGEABLE FOR ANY ADDITIONAL QUALIFICATION AND TEST REPORTS PERFORMED OUTSIDE THE SCOPE OF THE STANDARD PRODUCT SPECIFICATIONS.
- UNLESS OTHERWISE APPROVED BY AMPHENOL, ALL PARTS AND COMPONENTS ARE DESIGNED & BUILT ACCORDING TO AMPHENOL'S SPECIFICATIONS WHICH ARE SUBJECT TO CHANGE WITHOUT NOTICE.

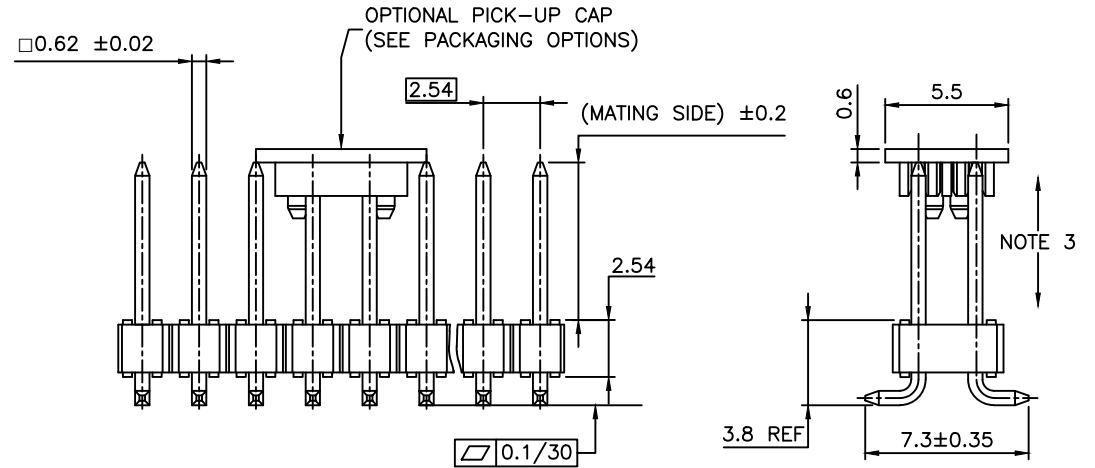
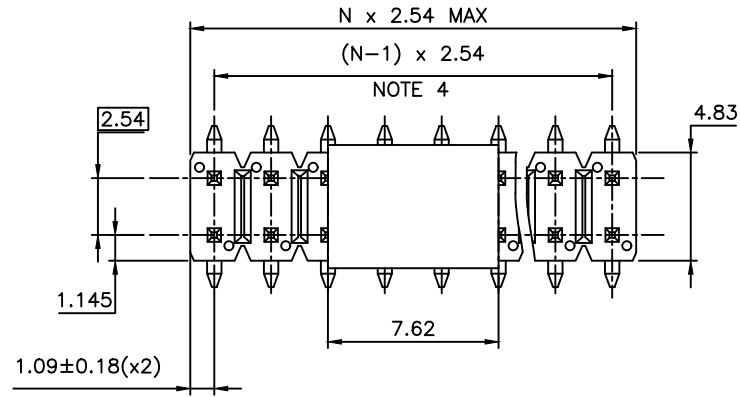

mat'l. code		surface		tolerance		projection		product family	
		ISO 1302		ISO 406 ISO 1101		mm		BERGSTIK	
ltr	ecn no	dr	date	tolerances unless otherwise specified		mm		title	
AE	F-36577	DDE	20.03.31	angles	linear	x.x ±0.3		UNSHR.HEADER	
AF	F-41211	DDE	21.06.15			x.xx ±0.13		DR SMT	
AG	F-43471	DDE	22.01.03			x.xxx ±0.05		scale 5:1	
AH	F-47109	DDE	23.01.25	dr	D.LE	01.01.24		dwg no	
AJ	F-49477	DDE	23.10.12	enfr	JM.C	01.01.24		sheet 1 of 2	
AK	F-52811	DDE	24.09.05	chr	JM.C	01.01.24		size	
AL	F-54452	DDE	25.01.28	appd	JF.N	01.01.24		A3	
sheet		revision		AL	X			type	
index		sheet		1	2			CUSTOMER Drawing	

PRODUCT NUMBER

95278-YXX-XXLF

EXTENDED RANGE

- RoHS COMPATIBLE, SEE NOTE 5
- TOTAL NB OF POSITIONS 04 TO 50
- PACKAGING OPTIONS, SEE ON RIGHT (MAY BE SUBJECT TO TOOLING FEES)
- PIN STYLE, SEE BELOW (AS AVAILABLE)
- PLATING, SEE ON RIGHT (AS AVAILABLE)

PIN STYLE	MATING
01	5.90
02	8.00
03	9.90
04	11.40
05	9.20
06	10.40
07	5.30
09	17.00
10	8.10
11	8.50
12	3.05
13	14.35
14	4.00
15	6.60
16	3.30

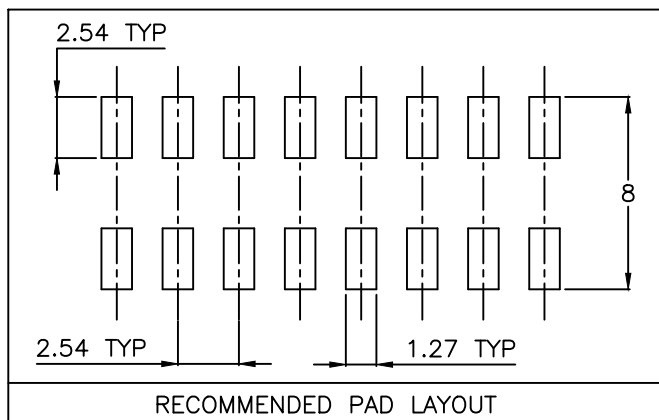

PACKAGING :

- = POLY BAGS
- B = TUBE + CAP - ONLY AVAILABLE UPON REQUEST
- A = TAPE & REEL WITH CAP, AS AVAILABLE
CAUTION: CAP ON 95278-YXX-04LF IS ORIENTED 90° VERSUS OTHER NB OF POSITIONS
- AV = TAPE & REEL WITH PICK UP CAP FOR CUSTOMER DEDICATED PART
- ER = TAPE & REEL WITH CAP, FOR CUSTOMER DEDICATED PART AND SPECIFIC LABEL ON REEL
- ERB = TUBE WITH PICK UP CAP, FOR CUSTOMER DEDICATED PART AND SPECIFIC LABEL
- TR = CUSTOM TAPE & REEL WITH CAP, SEE TA840
ONLY FOR P/N : 95278-102TR04LF
95278-101TR10LF
95278-801TR04LF
- T = TUBE WITHOUT PICK UP CAP
ONLY AVAILABLE UPON REQUEST
- K = TAPE & REEL WITHOUT PICK UP CAP, AS AVAILABLE

PLATING :

- 1 = 0.76µm GOLD/GXT ON CONTACT AREA, 2µm TIN MIN ON TAIL
 - 4 = 2µm TIN MIN FULL PLATED
 - 8 = 0.38µm GOLD/GXT ON CONTACT AREA, 2µm TIN MIN ON TAIL
- 1.27µm NICKEL MIN UNDERLAYER FOR ALL PLATING VERSIONS

mat'l. code		surface ISO 1302 <input checked="" type="checkbox"/> ISO 406 <input type="checkbox"/> ISO 1101 <input type="checkbox"/>		tolerance ISO 406 <input type="checkbox"/> ISO 1101 <input type="checkbox"/>		projection 		product family BERGSTIK	
ltr	ecn no	dr	date	tolerances unless otherwise specified		title			
W	F-47109	DDE	23.01.25	angles	linear	mm		UNSHR.HEADER DR SMT	
X	F-54452	DDE	25.01.28			scale N/A			
S	B-20276	LMU	15.02.16	dr	D.LE	01.01.24	dwg no		sheet 2 of -
T	B-20561	AMA	15.03.26	engr	JM.C	01.01.24	size		A3
U	F-22120	BVE	15.10.09	chr	JM.C	01.01.24	95278		
V	F-41211	DDE	21.06.15	appd	JF.N	01.01.24	type		CUSTOMER Drawing
sheet index	revision	sheet							