

PRODUCT NUMBER
95293-XXX-XXLF

RoHS COMPATIBLE, SEE NOTE 6
TOTAL NB OF POSITIONS, 3 TO 17
PACKAGING TYPE, NOTE 3

PLATING

- 1= 0.76µm GOLD/GXT ON CONTACT AREA, 2µm MATTE TIN MIN ON TAILS
- 4= 2.0µm MATTE TIN MIN FULL PLATED
- 5= 0.25µm GOLD/GXT ON CONTACT AREA, 2µm MATTE TIN MIN ON TAILS ONLY AVAILABLE UPON REQUEST
- 8= 0.38µm GOLD/GXT ON CONTACT AREA, 2µm MATTE TIN MIN ON TAILS
- 1.27µm NICKEL MIN UNDERLAYER FOR ALL PLATING VERSIONS

CATALOGUE RANGE	
PIN STYLE	MATING
01	5.84
02	8.08

APPLICATION SPECIFIC	
PIN STYLE	MATING
05	9.60
06	3.00
07	11.20
08	13.40
09	7.50
10	6.94
11	5.30
12	7.80

NOT TOOLED
NOT TOOLED
NOT TOOLED

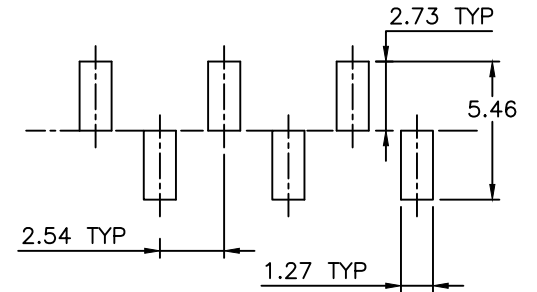
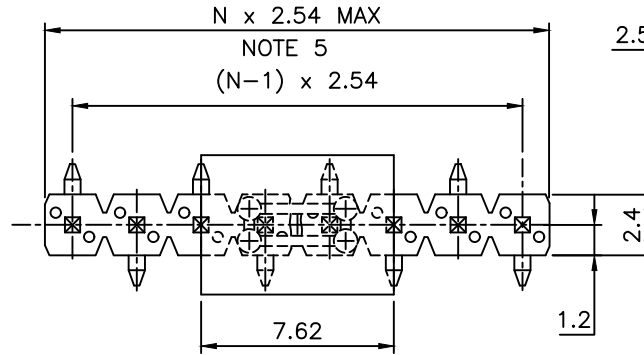

RECOMMENDED PAD LAYOUT

NOTES:

- 1 - HOUSING MAT'L : HIGH TEMPERATURE THERMOPLASTIC. UL94V-0 COLOR: BLACK
- 2 - PIN MATERIAL : PHOSPHOR BRONZE
- 3 - PACKAGING
 - = POLY BAGS
 - B = TUBE + CAP - ONLY AVAILABLE UPON REQUEST
 - A = TAPE & REEL + PICK-UP CAP, AS AVAILABLE
 - K = TAPE & REEL WITHOUT PICK-UP CAP, AS AVAILABLE
 - ER = TAPE & REEL WITH CAP, FOR CUSTOMER DEDICATED PART AND SPECIFIC LABEL ON REEL
- 4 - 9N MIN RETENTION IN EITHER DIRECTION
- 5 - TO DETERMINE DIMENSIONS :
N = NUMBER OF POSITIONS
EXAMPLE : 8 POS N x 2.54 = 20.32mm
6. RoHS COMPATIBLE PRODUCT SPECIFICATIONS

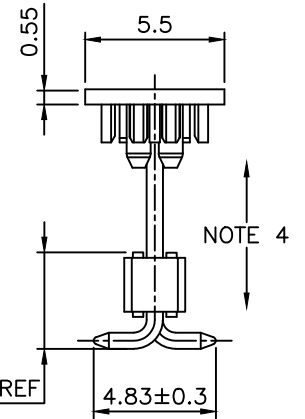
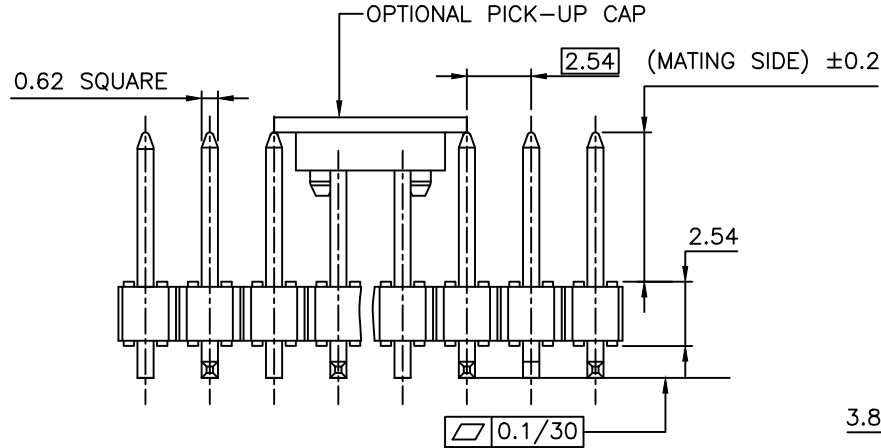

- a - PLATING:
 - "LF" MEANS THE PRODUCT IS LEAD-FREE, 2µm MINIMUM MATTE TIN OVER 1.27µm MINIMUM NICKEL UNDERPLATE.
- b - MANUFACTURING PROCESS COMPATIBILITY
 - THE HOUSING WILL WITHSTAND EXPOSURE TO 260°C PEAK TEMPERATURE FOR 30 SECONDES IN A CONVECTION, INFRA-RED OR VAPOR PHASE REFLOW OVEN.
- c - LABELING:
 - MEETS PACKAGING SPECS AS PER GS-14-920
- d - LEGAL STATEMENT: SEE GS-47-0004

mat'l. code		surface		tolerance		projection		product family	
SEE NOTES		ISO 1302 ✓		ISO 406 ISO 1101				BERGSTIK	
ltr	ecn no	dr	date	tolerances unless otherwise specified		mm		title	
X	F-47110	DDE	23.01.25	angles	linear			UNSHR.HEADER	
Y	F-50319	DDE	24.01.08	or ±z'		scale 5:1		SR SMT	
AA	F-52812	DDE	24.09.05					dwg no	
AB	F-54186	DDE	25.01.08	dr	D.LE	01.01.24		sheet 1 of 1	
				enfr	JM.C	01.01.24		size	
V	F-31174	DDE	18.09.05	chr	JM.C	01.01.24		95293	
W	F-35575	DDE	19.12.06	appd	JF.N	01.01.24		A3	
sheet		revision						type	
index		sheet						CUSTOMER Drawing	