

TABLE 1	
AHSP P/N	LENGTH "A"
NJBBAE-0001	1000±20MM

REVISIONS						
ZONE	REV.	ECN	DESCRIPTION	BY	DATE	APPROVED
ALL	1.0	MHAN-18101702	NEW RELEASE	HCL	10/17/2018	M.HANRAHAN
	A	MHAN-19080202	UPDATED HOUSING LATCH AREA TO MATCH GEN3 SFP+ DESIGN ADDED .004 TO ITEM 9 QTY.	KLP	6/24/2019	M.H.

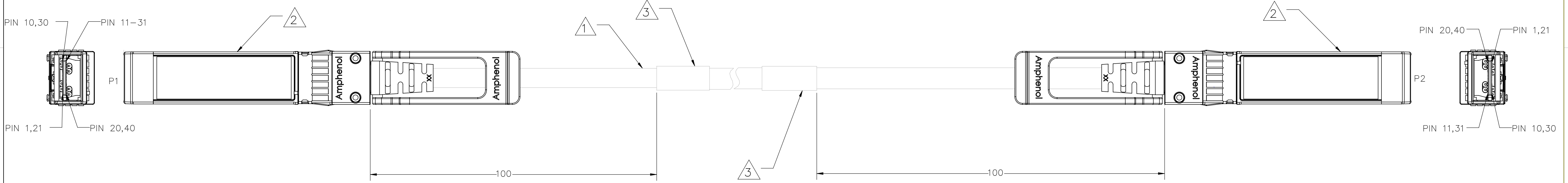
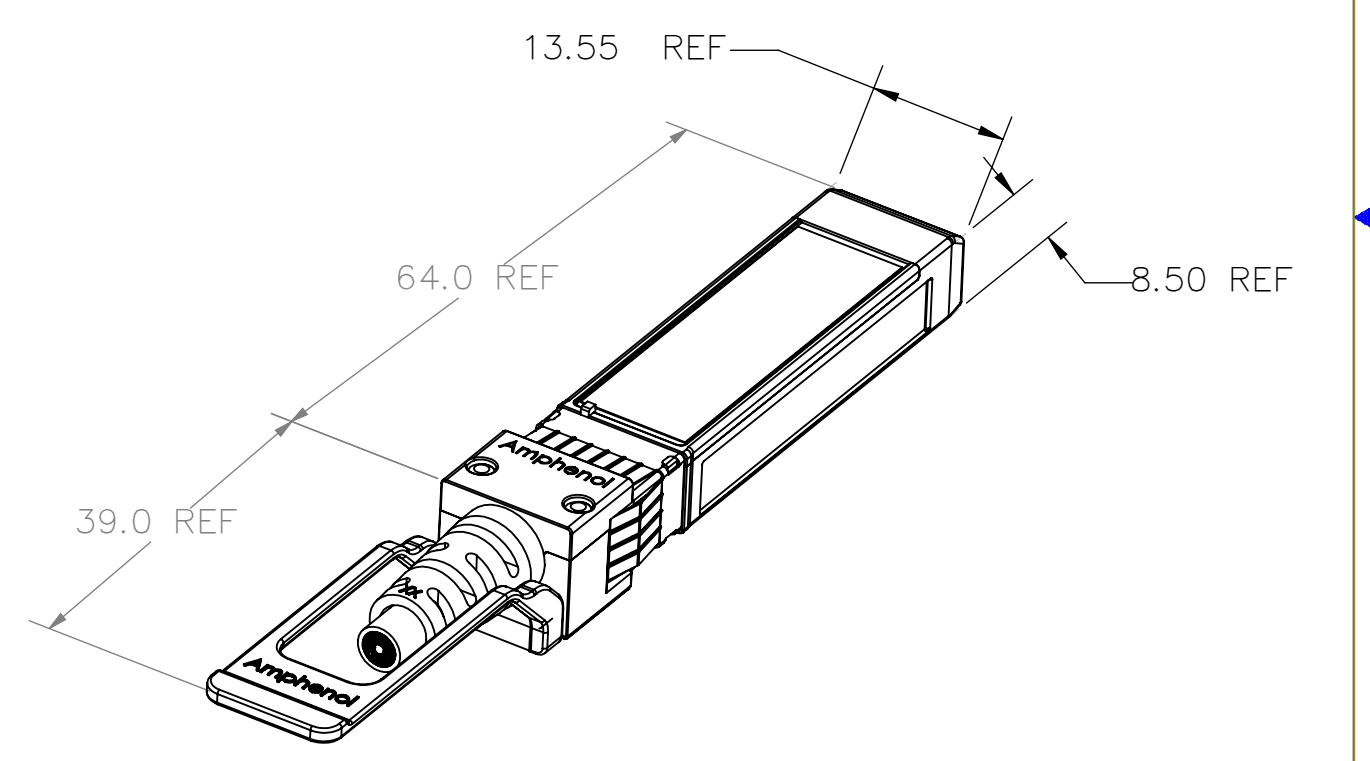
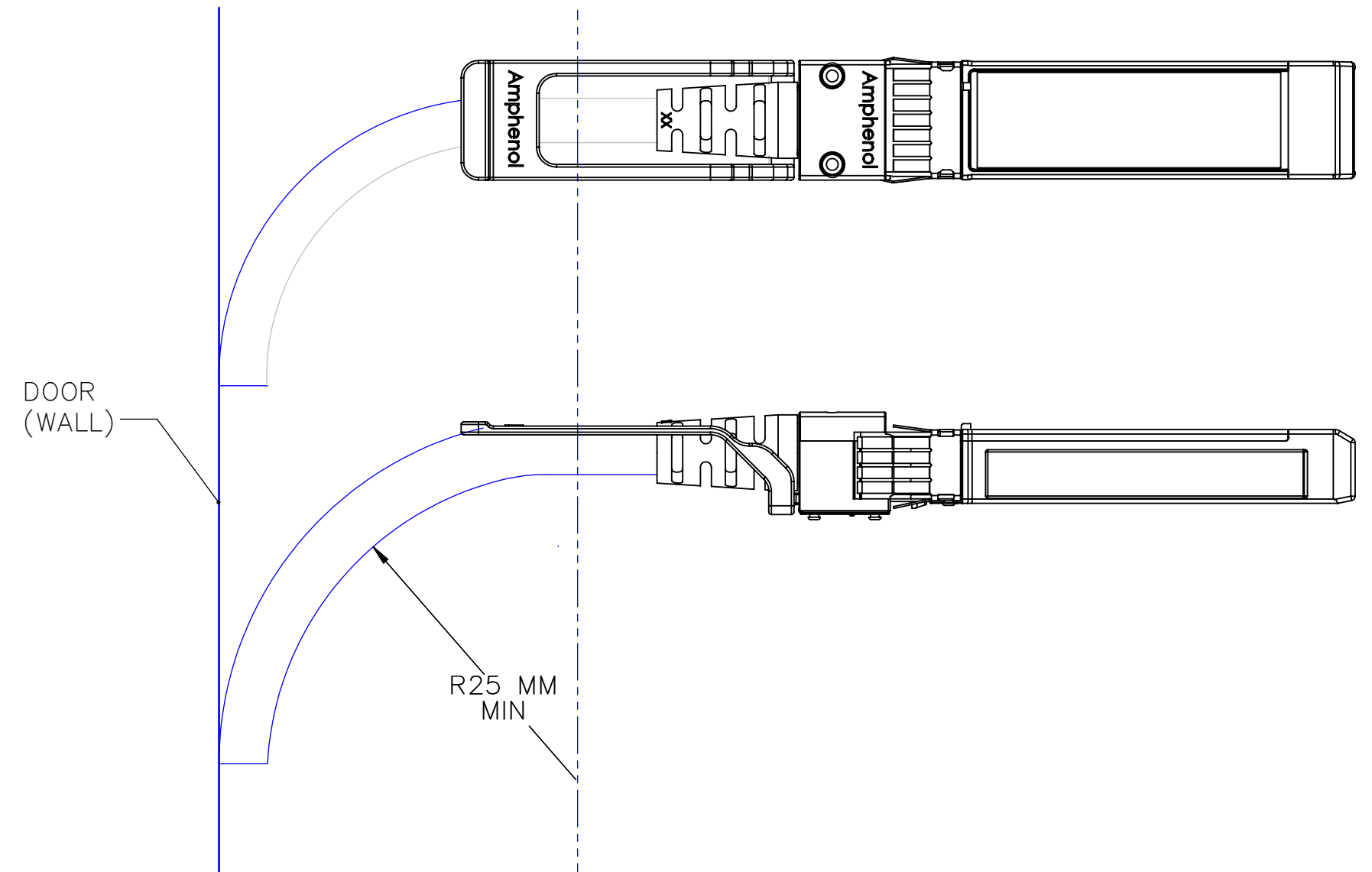

TABLE 2	
ITEM No.	DESCRIPTION
①	32 AWG, 4PR, EXD-28 UL 75 °C CM
②	PLUG, SFP-DD, REFERENCE "SFP-DD MSA"
③	LABEL, WRAPPED - AHSP P/N, REV. DATE CODE, LENGTH, CoO, SERIAL NUMBER & WEEE LOGO AND CE LOGO
4	EPROM - REFERENCE SFF-XXXX, PAGE A0 ONLY



- NOTES:
- THIS DRAWING IS RESERVED FOR AMPHENOL.
  - ASSEMBLIES SHALL BE COMPLIANT TO SFP-DD MSA SPECIFICATION.
  - CABLE ASSEMBLIES, COMPONENTS AND SUB-COMPONENTS SHALL BE COMPLIANT TO EU DIRECTIVE 2011/65/EU-RoHS2.
  - CABLE ASSEMBLIES MUST MEET SHIELDING EFFECTIVENESS REQUIREMENTS OF 35DB MINIMUM FROM 1-10GHZ AND 30DB FROM 10-18 GHZ.
  - EPROM CONTENT SHALL BE COMPLIANT WITH SFF-XXXX SPECIFICATIONS FOR 100GBASE-CR-4. EPROM REVISION IS EQUAL TO CUSTOMER PART NUMBER REVISION UNLESS OTHERWISE NOTED.
  - PACKAGE COMPLETED ASSY IN AN APPROPRIATELY SIZED ESD BAG.
  - UL LABEL MUST BE ON SHIPPING CARTON PER SUBJECT 764 OF THE UL COMPONENT WIRING HARNESS (ZPFW2) FILE #E86140. CSA LABEL MUST BE ON SHIPPING CARTON.



INTERPRET PER ASME Y14.5  
CODE IDENT 31413

TOLERANCES	DWN 10/17/2018 HCL	<b>Amphenol AHSP</b> A Division of Amphenol Corporation 200 Innovative Way, Suite 201, Nashua, N.H. 03062 (603) 879-3000	TITLE	CABLE ASSEMBLY, SFP-DD 32 AWG
0.0 ± 0.1	CHK 10/17/2018 M.HANRAHAN		PART NO.	SEE TABLE 1
0.00 ± 0.08	APVD 10/17/2018 M.HANRAHAN		DRAWING NO.	C-NJBBAE-0099
0.000 ± -	ANGLES ± 1.0°		SIZE	D
UNLESS OTHERWISE SPECIFIED DIMENSIONS ARE IN MM		SCALE	2:1	SHEET 1 OF 2
CUSTOMER USE DRAWING		REV	N/A	
		REV	A	

REVISIONS						
ZONE	REV.	ECN	DESCRIPTION	BY	DATE	APPROVED
			SEE SHEET 1			

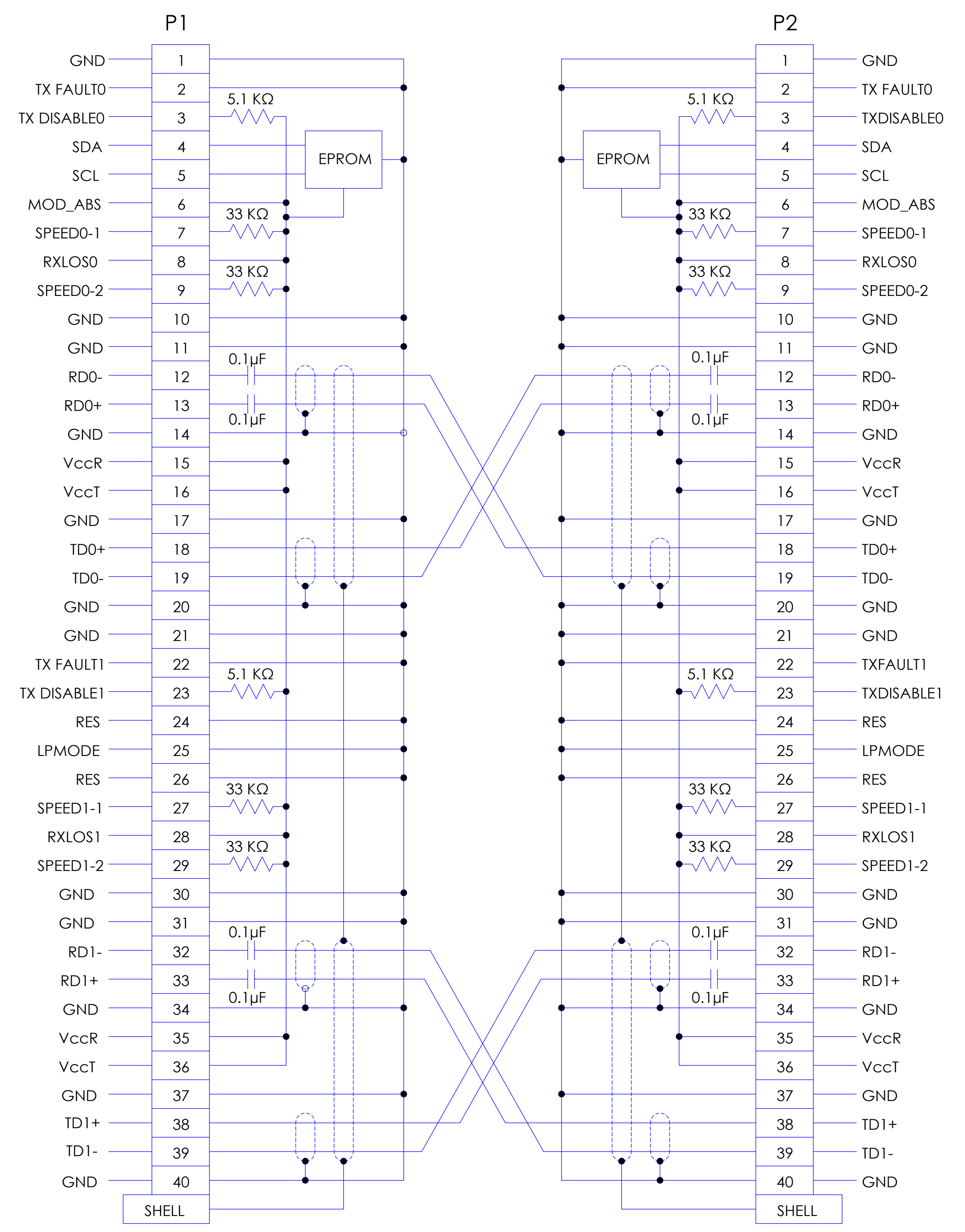

TOLERANCES	DWN	10/17/2018	HCL
0.0	± 0.1	CHK	10/17/2018
0.00	± 0.08	M.HANRAHAN	
0.000	± -	APVD	10/17/2018
ANGLES	± 1.0°	M.HANRAHAN	

**Amphenol AHSP**  
 A Division of Amphenol Corporation  
 200 Innovative Way, Suite 201, Nashua, N.H. 03062 (603) 879-3000

TITLE  
**CABLE ASSEMBLY, SFP-DD  
 32 AWG**

INTERPRET PER ASME Y14.5  
 CODE IDENT 31413

CUSTOMER USE  
 DRAWING

PART NO.	SEE TABLE 1	REV	N/A
DRAWING NO.	C-NJBBAE-0099	REV	A
SIZE	D	SCALE	1:1
		SHEET	2 OF 2