

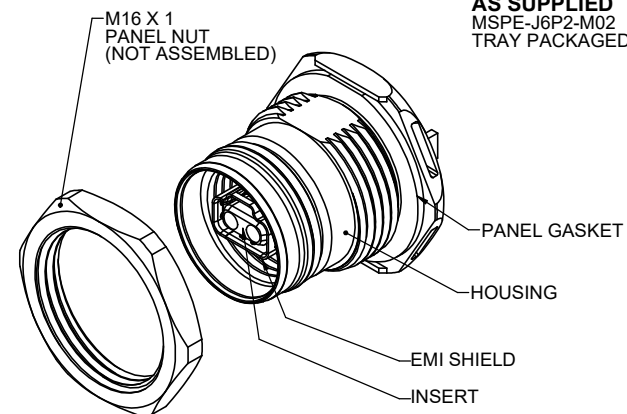

REVISIONS			
REV	DESCRIPTION, ECN, EAR NO.	DATE	APP'D
A	PRODUCT DRAWING (EAR 15028)	DEC02/21	K.L.

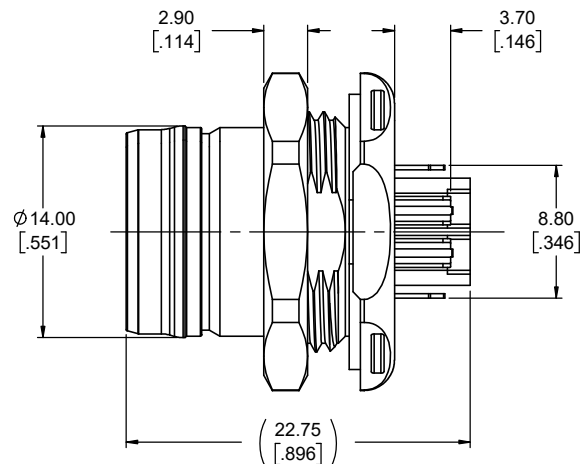

JACK COMPONENTS AS SUPPLIED
MSPE-J6P2-M02
TRAY PACKAGED

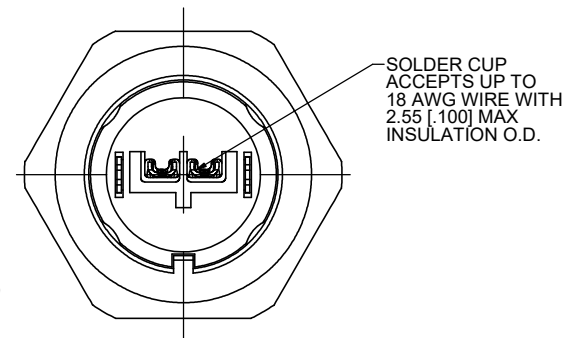
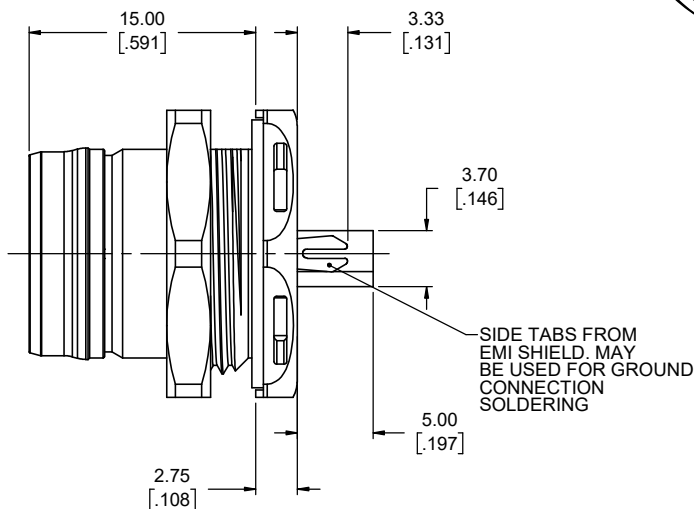
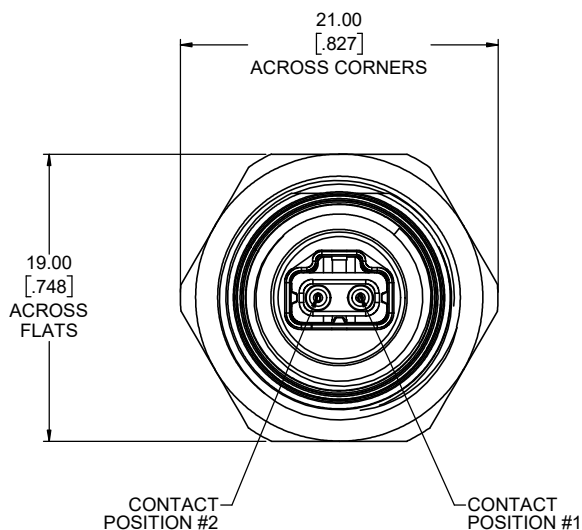

NOTES:

- MATERIALS: ALL MATERIALS ARE RoHS COMPLIANT PER EU DIRECTIVE 2011/65/EU AND AMENDMENTS.
 - HOUSING: DIECAST ZINC ALLOY PLATED WITH NICKEL OVER COPPER
 - INSERTS: ENGINEERING THERMOPLASTIC, UL94V-0 FLAMMABILITY RATING, COLOUR: BLACK
 - EMI SHIELD: STAINLESS STEEL PLATED WITH MATTE TIN OVER NICKEL
 - CONTACTS: COPPER ALLOY PLATED WITH NICKEL OVERALL, 0.76µm (30µ") GOLD ON THE MATING AREA, AND MATTE TIN ON THE TAILS
 - PANEL GASKET: SILICONE RUBBER, COLOUR: BLACK
 - PANEL NUT: BRASS ALLOY PLATED WITH NICKEL
- DESIGNED IN ACCORDANCE WITH IEC STANDARDS 63171-6 & 61076-2-010. COMPATIBLE WITH:
 - IEEE 802.3cg, 10BASE-T1L & -T1S
 - IEEE 802.3bw, 100BASE-T1
 - IEEE 802.3bp, 1000BASE-T1
 - IEEE 802.3bu, POWER OVER DATA LINES (PoDL)
- ENVIRONMENTAL CHARACTERISTICS:
 - OPERATING TEMPERATURE: -40°C TO +85°C
 - IP67 RATED PERFORMANCE PER IEC 60529 IN MATED CONDITION.
- ELECTRICAL CHARACTERISTICS:
 - CURRENT RATING: 4A
 - VOLTAGE RATING: 60VDC
 - CONTACT RESISTANCE: 20mΩ MAX
 - DIELECTRIC WITHSTANDING VOLTAGE:
 - 1000VDC CONTACT TO CONTACT
 - 2250VDC CONTACT TO SHIELD

AMPHENOL PART NUMBER: MSPE-J6P2-M02

UNLESS SPECIFIED OTHERWISE	DRAWN	T. TRAN	OCT7/21
PRIMARY UNITS MILLIMETRES	CHECKED	K. LAMBIE	DEC02/21
SECONDARY UNITS INCHES	M.E. APP'D		
REFERENCE IN PARENTHESES	Q.A. APP'D		
GENERAL TOLERANCES	DWG APPR.		
1 DECIMAL PLACE	ENG. REL. NO.	EAR 15028	
2 DECIMAL PLACES	REF.		
3 DECIMAL PLACES	THIRD ANGLE PROJECTION		
ANGULAR DEGREES	DO NOT SCALE DRAWING		

Amphenol Canada Corp. Commercial Products	
MSPE SERIES, SINGLE PAIR ETHERNET, IP67 JACK, PUSH/PULL, SOLDER CUP TERMINATION, RoHS COMPLIANT	
DWG. NO.	REV
P-MSPE-J6P2-M02	A
CODE ID NO. 03554	DWG SIZE: X SCALE: 4:1 SHEET 1 OF 2



REVISIONS			
REV	DESCRIPTION, ECN, EAR NO.	DATE	APP'D
A	PRODUCT DRAWING (EAR 15028)	DEC02/21	K.L.

CONTACT POSITION	SIGNAL PER IEC 63171-6
1	BI_DA+
2	BI_DA-

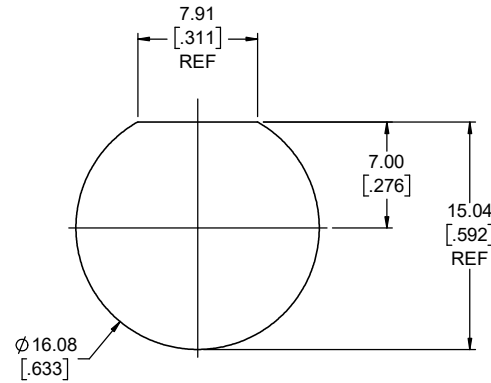

RECOMMENDED PANEL CUTOUT

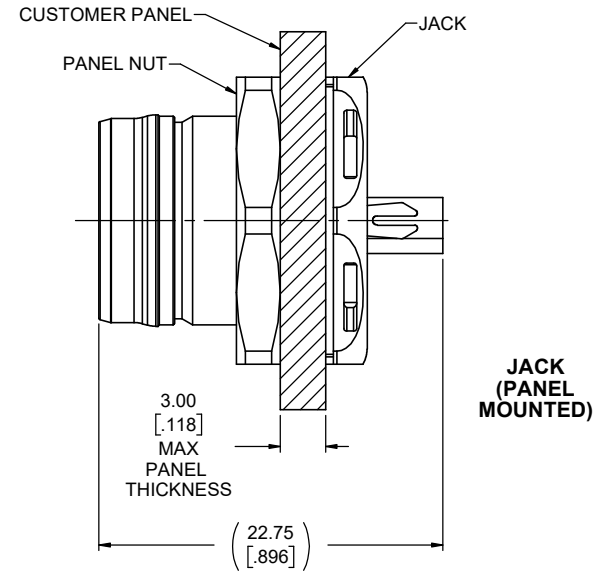

JACK (PANEL MOUNTED)

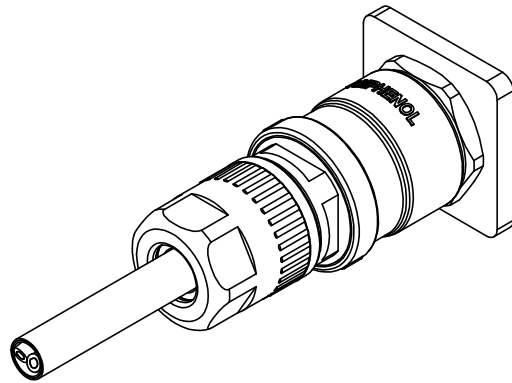

PUSH / PULL FUNCTION

- MATING**
- ALIGN MATING AREA
 - PUSH PLUG TO ENGAGE LATCH TO JACK

- UN-MATING**
- PULL FRONT PLUG COLLAR BACK APPROXIMATELY 1.2mm (.05") TO DIS-ENGAGE LATCH
 - PULL PLUG TO UN-MATE FROM JACK

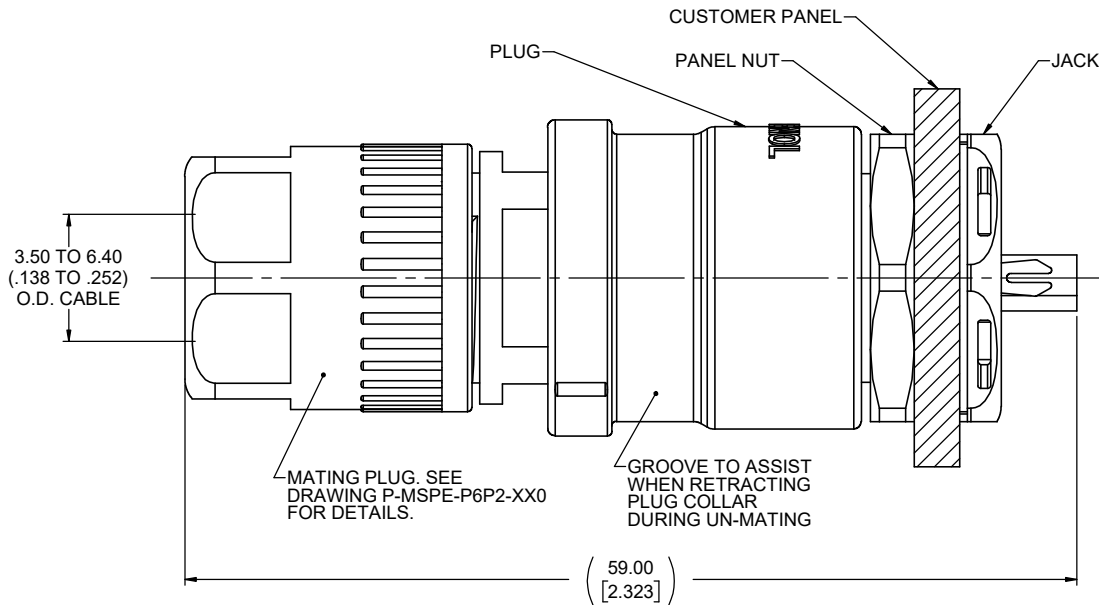

JACK WITH PLUG APPLICATION VIEW

UNLESS SPECIFIED OTHERWISE	DRAWN	T. TRAN	OCT7/21
PRIMARY UNITS MILLIMETRES	CHECKED	K. LAMBIE	DEC02/21
SECONDARY UNITS INCHES	M.E. APP'D		
REFERENCE IN PARENTHESES	Q.A. APP'D		
GENERAL TOLERANCES	DWG APPR.		
1 DECIMAL PLACE	ENG. REL. NO.	EAR 15028	
2 DECIMAL PLACES	REF.		
3 DECIMAL PLACES	THIRD ANGLE PROJECTION		
ANGULAR DEGREES			

Amphenol Canada Corp. Commercial Products	
MSPE SERIES, SINGLE PAIR ETHERNET, IP67 JACK, PUSH/PULL, SOLDER CUP TERMINATION, RoHS COMPLIANT	
DWG. NO.	REV
P-MSPE-J6P2-M02	A
CODE ID NO. 03554	DWG SIZE: X
SCALE: 4:1	SHEET 2 OF 2